

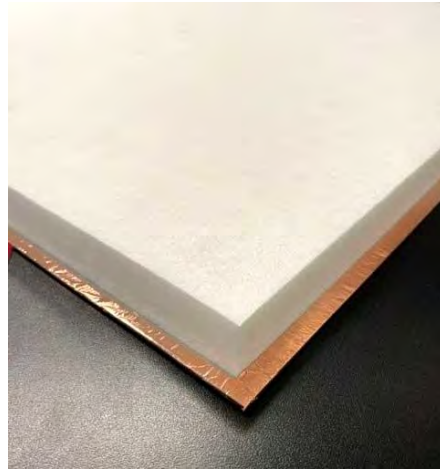

Installation of Xalon X8000T RF Shielded Ceiling Panels 2024 Rev. A



X8000T Panel

A drop down or suspended RF shielded ceiling system is composed of a commercial metal ceiling grid with 15/16" grid type (non-metallic grid systems will not work) and Xalon X8000T RF Shielded ceiling panels, that are placed into the grid. Two standard sizes that are available: 2'x2' and 2'x4'. RF shielded LED flat panel light fixtures (2'x2' & 2'x4') are also available. LED light strips attached to the bottom of the ceiling grid is another option. RF shielded air vent diffusers (2'x2') are available.

Xalon RF shielded ceiling tiles are designed to be inserted into a commercial grade, metal, suspended ceiling grid with 15/16" grid tees, that has been electrically grounded and all joints RF sealed using beryllium copper fingerstock with electrically conductive pressure sensitive adhesive (ECPSA) or RF gasketing and Xalon FS electrically conductive silicone RTV caulking (recommended), as needed to seal RF leaks. The **X8000T-KIT 2'x4' is used for border panels, oversize & undersize panels, notched panels, and irregular shaped panels.**

If the walls are RF shielded, install all the wall RF shielding layer(s) first, leaving the inner wall RF shield layer exposed, before installing the ceiling grid. This might be at the bottom of the grid wall molding or above, depending on the fire code.

Ideally, the ceiling grid perimeter wall molding will be attached directly in contact with the inner RF shielded wall layer (typically sheet metal, foil, or metalized fabric). If, due to fire code the 2nd layer of sheetrock must be installed, you will have to bring the wall shielding back down to the grid wall molding, on the inside of the 2nd layer of sheetrock. This can be done with ECPSA foil tape or 26-gauge galvanized steel flashing, or a combination of the two.



Connecting Suspended Ceiling Grid to Foil Shielded Wall

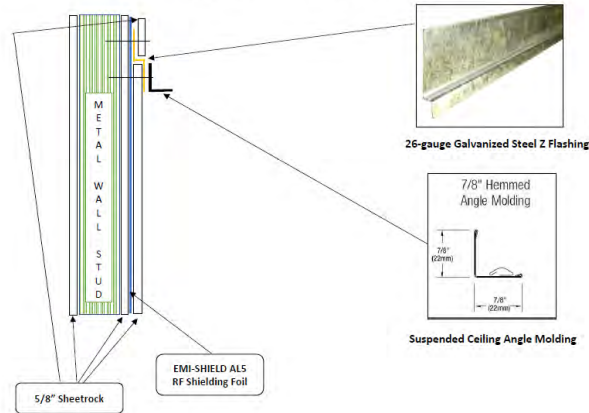

Larger drawing at the bottom of this document.



BEFORE INSTALLING CEILING GRID SYSTEM

Your need to make sure that every metal wall stud and metal ceiling or floor stud is connected electrically to earth ground. You might have to make more than one connection from the metallic grid to a good ground. Verify that all metal wall studs are earth grounded by continuity checking them using an ohmmeter or multi-meter. The suspended ceiling grid grounding is typically through the grounded metal wall studs (recommended) and metal ceiling studs (this is not typical or recommended). Even if the walls are not RF shielded, it is a good idea to make sure all the metal wall studs are grounded. The Xalon RF Shielding System relies on multi-point grounding to maximize the RF shielding performance. For non-metallic framing, designated grounding wires will have to be added, from the metal ceiling grid to earth ground (this is not common).

INSTALLATION OF THE MAIN BEAMS & CROSS TEES

Most contractors already know how to install a suspended ceiling system. We typically use Armstrong suspended ceiling grid system components.

If you do need instructions, please use the Armstrong installation instructions. <https://www.armstrongceilings.com/residential/en-us/project-ideas-and-installation/drop-ceiling-installation.html>



RECOMMENDED SUSPENDED CEILING GRID SYSTEMS

[ACP Classic X Cliq](#)

[Armstrong Prelude ML \(preferred\)](#)

[Armstrong Prelude XL \(preferred\)](#)

[Armstrong Prelude XM \(preferred\)](#)

[CertainTeed Classic Aluminum Capped Stab System](#)

[CertainTeed Classic Environmental Stab System](#)



Only the portion facing into the room is coated or painted

For retrofit of acoustic panels to RF shielded panels, most existing, commercial grade, metal ceiling grid systems can be made to work.

INSTALLATION OF BERYLLIUM COPPER FINGERSTOCK

Skin contact with Xalon FS or beryllium copper fingerstock may cause irritation in some sensitive individuals with an allergic dermal response. Please wear TPE, neoprene, or nitrile gloves to avoid this.

For ready to install main beams, now is a good time to install the beryllium copper fingerstock pieces on to the main beams. It is much easier to work on a table then overhead. Thoroughly clean the top side of the main beam tee. Remove the release tape from the fingerstock and install the fingerstock, with the tape side towards the outer folded over edge or hem (see drawings below), making sure it is lying flat in

©2023 Xalon RF Shielding Systems 1-833-XalonRF (833.925.6673) www.xalonrf.com

For Technical Sales, Eric Evans, RA Mayes Company 1-800-742-9447 www.ramayes.com



the horizontal tee portion. Press down firmly on the fingerstock, along the length of the fingerstock to assure good adhesion of the fingerstock on to the main beam. Fill in both sides of the main beam with fingerstock by butt jointing the fingerstock, along the entire length of the main beam. Cut off any extra fingerstock at the end or precut the last fingerstock near the end with good quality shears. Then install the main beams as you normally would.

For the cross tees, follow the same procedure as the main beams. But do not install the cross tees to the wall angle molding at this time. All the other cross tees can be installed.

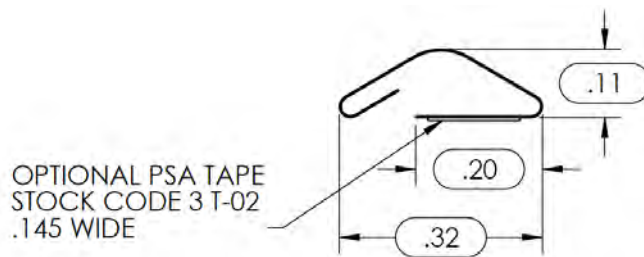

Profile view of fingerstock

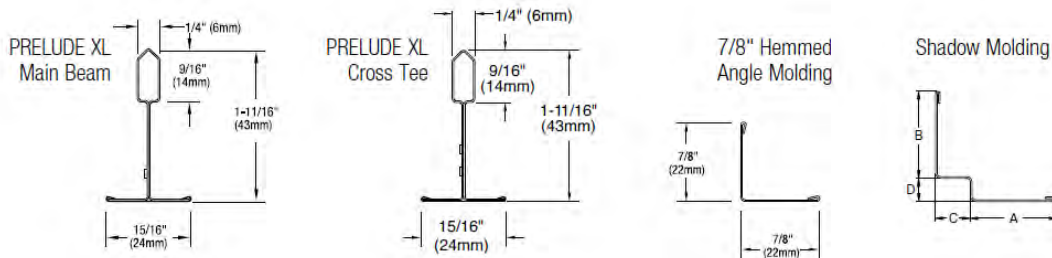



Profile view of ceiling grid components

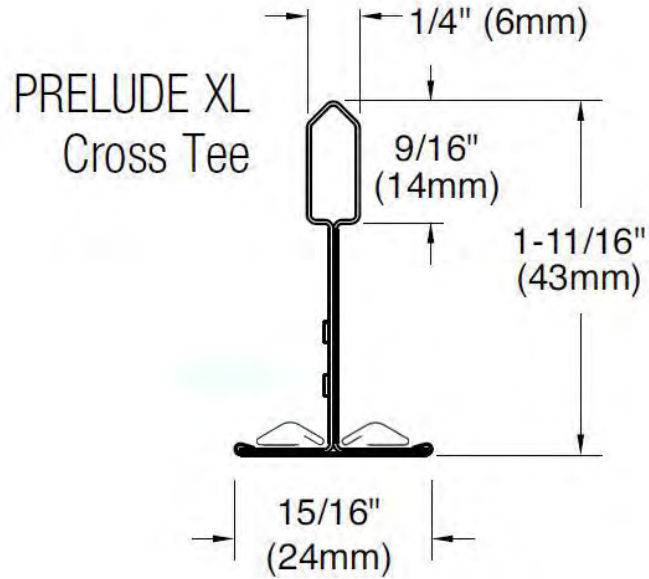

Profile view of fingerstock installed (both sides) of main beam & cross tee

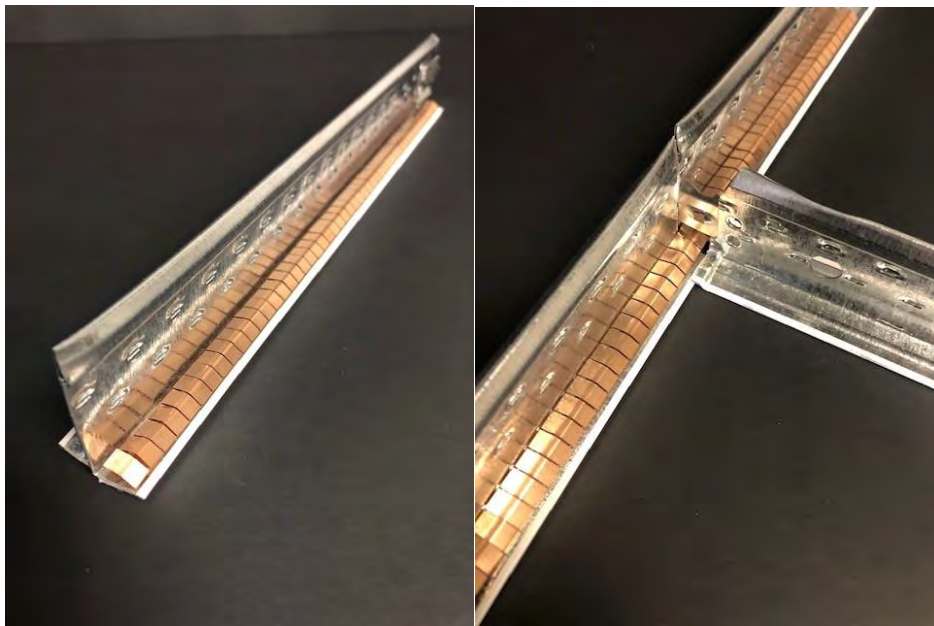

Pictures of fingerstock installed on a main beam



INSTALLING WALL MOLDING ANGLES

For the wall molding, fully install it all, without the fingerstock attached. You will want to check electric continuity (resistance) between a known earth ground and each piece of the molding. The inside and outside corners will have to be miter cut, typically at 45°. After all the angle molding is installed, install the fingerstock, like you did for the main beams and cross tees.

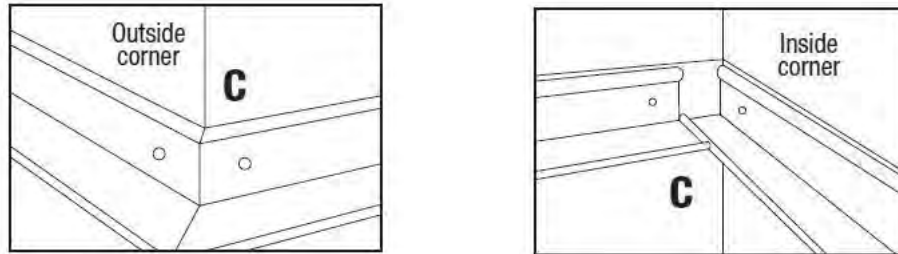

Correctly Miter Cut Outside Corner Incorrectly Done Inside Corner

For RF shielded walls, you must maintain the shielding integrity of the wall system you are attaching or anchoring through. Metal screws going through the ceiling grid perimeter angle moulding, through the RF shield layer, through the sheetrock or plywood and anchoring into the grounded metal wall stud is recommended. Due to the many different shielded wall systems, it will be left to the installer. Usually with a combination of flashing and foil tape with electrically conductive adhesive.

For non-shielded walls, fasten the wall angles securely to the wall at all points. Screw them firmly to grounded metal wall studs, using clear zinc coated drip point screws. Use clear zinc coated screws for wood studs. Use screw anchors or other masonry fasteners on brick or masonry walls.

7/8" Hemmed
Angle Molding

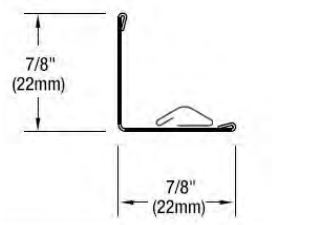

Profile view of fingerstock installed in the angle molding



SUSPENSION WIRES FOR MAIN TEES

Install your suspension wires as you would normally for a commercial installation. You may need these suspension wires later, if you find portions of the ceiling grid are not tied to earth ground.



Be sure the suspension wires are securely fastened

INSTALLING BORDER CROSS TEES TO WALL ANGLE MOLDING

Border cross tees are installed between the wall angle and the outer main beams.

If you have not already installed the fingerstock on to the main beams and wall angle molding, apply the fingerstock now.

Install the cross tees in to the main beams, as you normally would. The cross tees may or may not have the fingerstock already installed. The fingerstock installed on the main beams and angle moldings, should not be affected.

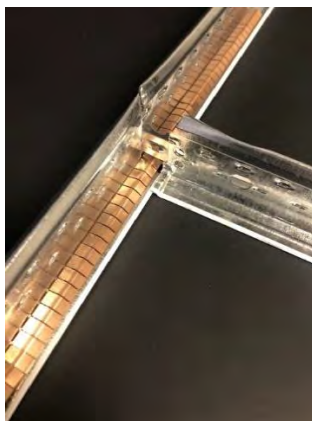

Installed cross tee connection to main beam



BEFORE INSTALLING CEILING PANELS

Your need to make sure that every grid component is connected electrically to earth or electric ground. You might have to make more than one connection from the metallic grid to get a good ground. Verify that all ceiling grid components are grounded by continuity checking them using an ohmmeter or multi-meter. Your resistance reading needs to be less than 5 ohms, the lower the better.



Use Xalon FS electrically conductive silicone caulking to cover up all joints or gaps on the top side of the inverted T channel, Tees, expansion joints, and angle molding. Typical areas are; where the cross tees tie into the main beams, cross tees tie into the angle molding and where you have tee joints. From the top of the ceiling grid, apply Xalon FS from the inward side of the fingerstock working inwards at angle molding and main beam joints. For cross tee to main beam connection, along the edge of the cross tee to main beam or angle molding intersection. Let the Xalon FS set up for 24 hours before installing the ceiling panels.



Cross Tee to Main Beam Intersection



Xalon FS



CUTTING THE XALON RF SHIELDED CEILING PANELS

The Xalon X8000T RF shielded panels are come in two sizes 2' x 2' and 2' x 4' preassembled at the factory, so they are ready to install in the ceiling grid.

The X8000T-KIT panels, only come in a 2x4 (23.75" x 47.75") size. The KIT includes the aluminum shielding panel, the tegular acoustic panel and the copper perimeter tape all come separately. Tegular adhesive is not supplied, but 3M 94 ET aerosol is recommended, available nationwide.

The 8000T-KIT is used for border panels, oversize & undersize panels, notched panels, and irregular shaped panels. See below for cutting a hole in a preassembled X8000T panel.

First. cut the aluminum RF shielding panel to size. Measure twice and cut once. We recommend metal nibblers or metal shear; a saber saw with a fine-tooth blade will also work. File and sand down any rough edges.



The aluminum shielding panel will be cut $\frac{1}{2}$ " wider and $\frac{1}{2}$ " longer than the ceiling grid opening. If the ceiling opening has non-parallel edges, adjust your panel cut to compensate. Then round off all four 90° corners, $\frac{1}{16}$ " using a file or grinder.

Verify the panel was cut correctly by placing in into the ceiling grid, in its intended location. Now is a good time to put a mark(s) on the side that will be facing in to the room.

Next, apply downward pressure of the straight edge, compressing the tegular poly board. Then holding the utility knife perpendicular to the aluminum panel, cut the tegular board using a heavy duty, long blade, utility knife and a straight edge or steel L square. The tegular board is 1" thick, so make sure the cutting blade extends out more than 1".



The tegular panel will be cut 1/4" narrower and 1/4" shorter than the ceiling grid opening. If the ceiling opening has non-parallel edges, adjust your panel cut to compensate. Gently, use a butane lighter to smooth out any rough edges.

The tegular panel can also be straight cut using a table saw.

Verify the tegular panel was cut correctly by placing in into the ceiling grid, in its intended location. Now is a good time to put a mark(s) on the side that will be facing the aluminum panel, for a reference.

Next, scotch-brite and wipe off with microfiber towel the 1/2" or wider perimeter of the aluminum shielding panel, that you put the mark on. Next, tape off the perimeter of the aluminum shielding panel, that you put a mark on, using 1/4" painters' tape.

Then, using 1" wide or wider painters' tape, cover the 1" edges of the tegular board.

Now spray the marked side of the aluminum shielding panel and the marked side of the tegular panel using 3M™ 94 ET™ clear spray adhesive. 3M 94 ET spray adhesive stock number, 62-4870-4930-6 does not have a zero VOC (VOC < 20%), so you might have to spray them outside.

Bring the adhesive sprayed panels back to clean work table, do not let them touch. Place the aluminum shielding panel on the table with the adhesive facing up.

Now, remove the perimeter painters' tape from the aluminum panel. Next, remove the painters' tape from the tegular board.

We recommend the tegular board be attached to the aluminum panel with 30 minutes of being sprayed.

Then with an assistant, recommended, gently lower the tegular board on to the aluminum panel, leaving a 1/4" bare aluminum boarder around the perimeter of the aluminum shielding panel. The 3M adhesive will let you reposition the tegular panel. When you are satisfied with the tegular boards position, apply gentle downward pressure to the tegular



panel with a clean or clean gloved hand. Let the 3M adhesive cure for 60 minutes, before installing the panels in the ceiling.

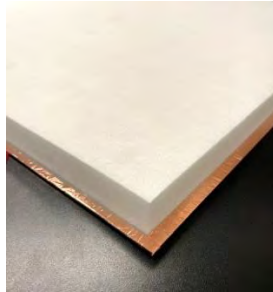

Finally, tape over the 1/4" bare aluminum perimeter with the 1/4" wide copper tape which has electrically conductive PSA. Smooth out the copper tape by applying pressure with your hand. The tegular panel and the copper tape are on the same side. See photo above. The panel is now ready to install in the ceiling grid.

CUTTING A HOLE IN THE XALON RF SHIELDED CEILING PANELS

The procedure is the same as above, but you need to cut a round hole in the aluminum ceiling panel and the tegular board with a fine-toothed hole saw. The hole saw must be over 1-1/8" deep.

Can you just cut a hole in a premade X8000T panel? Yes, tape, using blue painters' tape, a piece of cardboard on the tegular poly board, over the area where the hole will be cut, this keeps the debris from the hole saw from damaging the tegular face. Then mark the center of the hole on the cardboard.

Place the X8000T panel over a garbage can, or on a couple 2x4s, so the metal filings from the hole saw, going through the aluminum panel, drop out the bottom.

Cut from the card boarded, tegular side going towards the aluminum panel.

Clean up the aluminum hole with a round metal file and clean up the tegular poly board hole with a butane lighter, if needed.





REGULAR POLY BOARD MANUFACTURERS CUTTING DIRECTIONS

For the **straight cut**

General Information

- Wear gloves when preparing for work in order to protect the bluefiber panel/pad against dirt and stains. Do not use gloves when working directly with hand-held circular saws.
- Clean your workspace & required guide rails of dirt before starting processing to prevent staining of the panel/pad

Suitable Processing Tool

- Plunge saw (e.g. FESTOOL TS55 REBQ or equivalent)
- Saw blade: alternating tooth W48



Processing

1. Insert the saw blade according to the manufacturer's specifications and fix the plunge saw on the guide rail.
2. Mount additional splinter protection on the plunge saw and lower it onto the material. If necessary, replace the splinter protection on the guide rail.
3. Connect industrial vacuum cleaner.
4. Set the cutting depth (approx. 16 mm for material thickness 10, or 30 mm for material thickness 25). The saw tooth must protrude 4 - 5 mm. For this purpose, take into account both the respective material depth and the thickness of the guide rail (4 - 5 mm) on the scale of the plunge saw.
5. Insert screw clamps into the guide rail and fix the guide rail to the workpiece.
6. Set speed level to approx. 5000 - 6000 rpm (level 6 or equivalent) to achieve the best results with regard to fraying and surface of the edges. $v > 50$ m/s.
7. First place the guide rail, then place the plunge cut saw in front of the material and slowly guide it through the material.
8. Check the edge quality and rework as necessary, using fine sandpaper.

Note: In order to prevent hooking or to obtain a clean cutting pattern, make sure that splinter protection is provided on both sides (mounted on guide rail and plunge saw).





For shape cutting

General Information

- Wear gloves when preparing for work in order to protect the bluefiber panel/pad against dirt and stains. Do not use gloves when working directly with hand-held circular saws.
- Clean your workspace and required guide rails of dirt before starting processing to prevent staining of the panel/pad.
- Maximum workable material thickness: 25 mm

Recommended Processing Tool

- Pendulum jigsaw (e.g. FESTOOL PS420 EBQ or equivalent)
- Saw blade: jigsaw blade S75/2,5 mm



Processing

1. Insert the saw blade according to the manufacturer's specifications and, depending on which shape is to be cut, optionally fix the jigsaw on the guide rail.
2. Mount splinter shield on jigsaw and saw into it before starting work.
3. Connect industrial vacuum cleaner.
4. Optional: Insert screw clamps into guide rail and fix guide rail to workpiece.
5. Set pendulum stroke to maximum level (level 3 or equivalent), and speed to level A (= automatic, full power) to achieve the best results with regard to fraying & surface of the edges.
6. When switching on for the first time, cut the splinter shield
7. Place jigsaw in front of the material and guide it slowly through the material.
8. Check the edge quality and rework as necessary, using fine sandpaper.





INSTALL AIR VENTS

For air vents and return air vents, we recommend metal 2' x 2' air vents with metal backing or metal housing and metal reducer.



2' x 2' RF Shielded Diffuser - Bottom

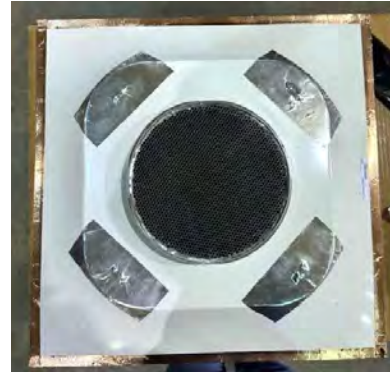

RF Shielded Air Vent Diffuser - Top

We recommend RF shielded honeycomb waveguide air vents for 60 dB and higher shielding effectiveness requirements. You can use full panel honeycomb panels or honeycomb with diffusers.

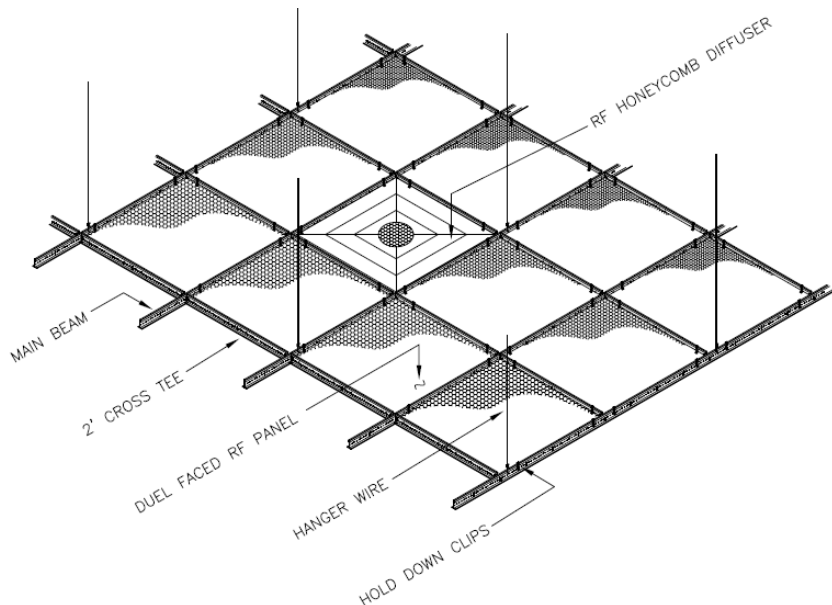

Honeycomb Waveguide Air Vents



For penetrations, like fire sprinkler penetrations, the hole you cut in the X8000T needs to be RF shielded, above the panel. You will need to get above the panels to radial tape, using electrically conductive pressure sensitive adhesive (ECPSA) foil tape, the metal pipe to the top of the RF panel. We recommend the Xalon ST5 aluminum tape for sealing the metal sprinkler pipe to the top of the X8000T panel.



If the pipe is not metal, you will need to spiral wrap EC foil tape around the pipe from the top of the panel, to least 6 times the diameter of the pipe. Then radial tape from your now taped pipe to the top of the RF panel.

Example: The pipe penetration is 2" in diameter, from the top of the RF panel, you will spiral wrap ECPSA foil tape up to a height of 12", then radial tape from the top of Xalon RF panel to the newly tape pipe penetration.

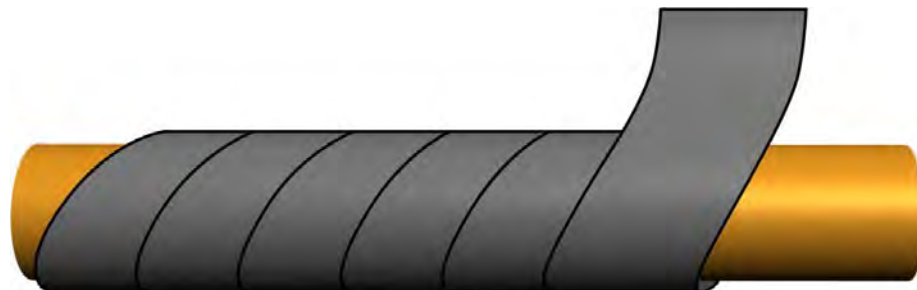

Wrapping Pipe with ECPSA Foil Tape

INSTALL LED FLAT PANEL LIGHT FIXTURES

For LED flat panel lighting, you can use 2'x2' or 2'x4' drop-in LED lighting fixtures, which are specially RF shielded and designed for this purpose. We offer the RF shielded, XLLF-2x2 and XLLF-2x4 suspended ceiling LED light panels, which are ready to install. You just need to connect the conduit to the fixture, connect the EMI filtered AC and set the switches. Backlit design delivers unmatched uniform light distribution. Easily adjust



brightness level (multi-lumen) 4000/ 5000/ 6000, via switch on fixture. Easily adjust color options (multi-CCT) 35K/ 40K/ 50K, via switch on fixture.



**Xalon X5000 RF Shielded Drop Ceiling
with 2x4 LED Flat Panel Lighting**

DISCLAIMER

Check national, state, and local codes before starting any project. Follow all safety precautions. Information in this document has been furnished by the National Retail Hardware Association (NRHA) and associated contributors. Every effort has been made to ensure accuracy and safety. Neither R. A. Mayes Company, Xalon RF Shielding Systems, NRHA, any contributor nor the retailer can be held responsible for damages or injuries resulting from the use of the information in this document.

©2023 Xalon RF Shielding Systems 1-833-XalonRF (833.925.6673) www.xalonrf.com

For Technical Sales, Eric Evans, RA Mayes Company 1-800-742-9447 www.ramayes.com



Connecting Suspended Ceiling Grid to Foil Shielded Wall

