

Technical Description
L Band J Series Compact Medium Power Amplifier
VZL-6943J2

INTRODUCTION

This document provides a detailed technical description of the CPI VZL-6943J2 L-band, J Series Compact Medium Power Amplifier (CMPA) designed specifically to provide broadband high power microwave output for EMC and general purpose test applications. Its compact, lightweight implementation of a wide band traveling wave tube permits continuous, efficient operation across the entire 1.0 to 2.5 GHz frequency range. A microprocessor-based system performs all of the J Series CMPA's monitor and control functions. Flash RAM based program instructions are easily updated via a serial port using a PC, instead of requiring unit disassembly to access an integrated chip (EPROM). Additionally, it features power factor correction (0.95 min.) allowing the unit to meet the total harmonic distortion requirement of EN60555-2. It is also certified to International Safety Standard EN-61010, and Electromagnetic Compatibility 89/336/EEC.

The VZL-6943J2 series CMPA along with the VZS/C-6963J2 (covering 2.0 – 8.0 GHz) and the VZM-6993J4 (8.0 – 18.0 GHz), cover the full 1.0 – 18.0 GHz in three CMPA units. The J Series CMPA family is a member of a comprehensive line of communication amplifiers including TWT Low Power Amplifiers (LPAs), Medium Power Amplifiers (MPAs), High Power TWT Amplifiers (HPAs) and High Power Klystron Amplifiers (KPA) designed specifically for service in commercial satellite earth stations operating in standard SATCOM frequency bands.

CPI (formerly Varian Electron Device Group) has been a recognized world leader in the field of microwave tube technology for over 50 years and has been active in the design and manufacture of a broad range of microwave power amplifiers and related products for more than 30 years. CPI Satcom Division (formerly Varian MEP) was organized in the mid-1970s to bring together, under a single business center, the strengths of the existing CPI divisions involved with commercial Satcom and Industrial power amplifiers.

Today, CPI Satcom Division has provided thousands of broadband power amplifiers and integrated satellite uplink power amplifiers in the L, S, C, X, Ku, DBS and Ka- band frequency ranges to worldwide users and has become the leading supplier of this class of products.



Figure 1. L-Band J Series CMPA

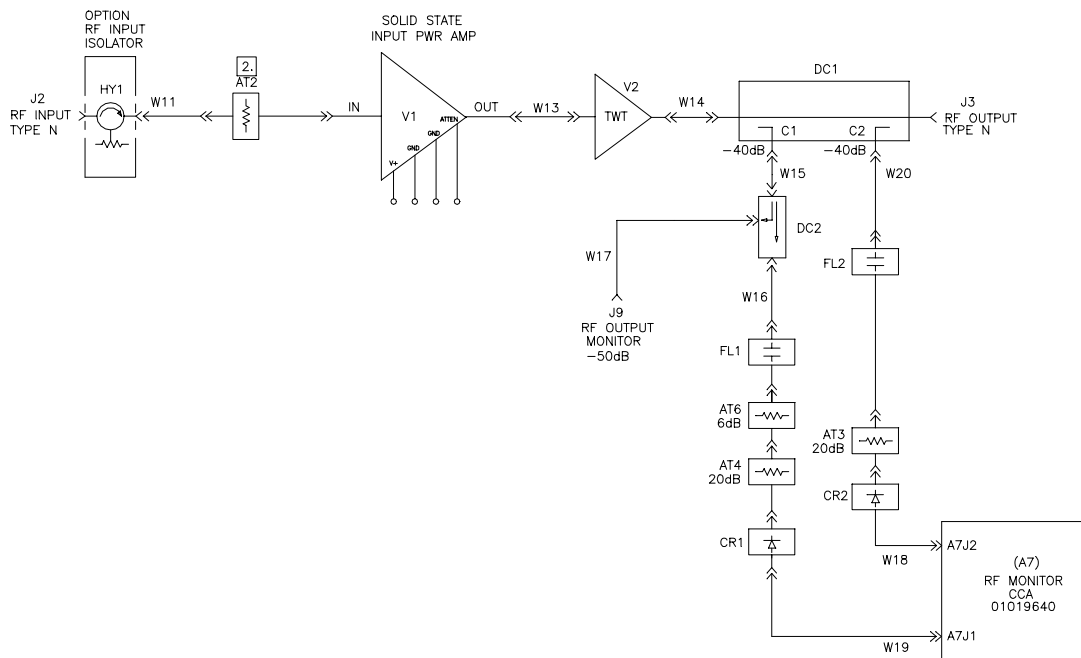

Figure 2. J Series CMPA RF Block Diagram

EQUIPMENT DESCRIPTION

General

The VZL-6943J2 series CMPA (Figure 1) is packaged in a 8.75 inch tall slide-mounted drawer suitable for standard 19-inch rack mounting. This enclosed assembly houses both the RF and power supply sections of the amplifier. The RF section includes the TWT, solid state intermediate power amplifier (IPA), RF detectors, output directional couplers and optional input isolator. The power supply section includes the power factor correction, power processor, and high voltage regulation circuitry. It also contains the micro-processor based monitor and control system necessary to permit safe, efficient and reliable operation of the J Series CMPA.

The VZL-6943J2 series CMPA is protected from operational damage caused by abnormal AC, DC, RF faults or insufficient cooling. The amplifier will automatically recycle itself after a prime power interruption or transient fault condition.

Personnel safety is of utmost importance and is safeguarded by proper grounding and by access interlocks and shields, which prevent physical entry into the high voltage sections. The unit is certified by TUV to meet EN61010 safety standards.

The front panel of the unit serves as the primary user interface housing the monitor and control system including a type N RF connector to sample and measure output RF power. The front panel of the unit includes a keypad, indicator LEDs and a vacuum fluorescent alphanumeric display. All unit functions can be controlled and monitored via the front panel.

Principal functions are also brought to the five user interface connectors located on the rear panel for remote monitor and control. Control, fault and monitoring functions are available via: the IEEE-488 (GPIB) port designed to interface directly with a computer, a second RS-422/485 port to be used when the optional CPI remote control panel is purchased, a separate switching port for use with switching/power combining subsystems, and a user interlock port for use when interfacing other equipment or controls with the J Series CMPA. Also, an RS-232 serial port is provided for flash programming or control.

Digitally controlled attenuation allows for RF drive attenuation adjustment via the serial remote and CIF interface ports, thereby enhancing remote monitor and control capabilities.

To expedite field maintenance procedures, the VZL-6943J2 series CMPA utilizes a modular design approach consisting of Line Replaceable Units (LRUs), which permit service personnel to maintain the J Series CMPA in the field without need of returning the entire unit to the depot or factory. Comprehensive fault reporting and diagnostic procedures allow field personnel to localize the fault to the individual LRU, make the necessary replacement and return the amplifier to service with a minimum of operational downtime.

The overall amplifier enclosure measures approximately 19" (w) x 8.75" (h) x 26" (d), plus air duct adapters, and weighs approximately 95 lbs. The TWT Amplifier can be installed in a 1:1, 1:2 or 1:3 auto switching, or power combined configuration as needed by end user mission.

RF Subsystem

A conservative field-proven approach is utilized in the J Series CMPA RF subsystem. The RF block diagram (Figure 2) identifies all major circuit elements for this technical description.

A low level RF input signal is applied to the J Series CMPA via a type N connector located at the rear of the enclosure. If included, the optional input isolator limits the input VSWR to a level of 2.0:1 or less (1.7:1 typical) back to the source. The RF input is then routed to the SSIPA which includes an internal variable attenuator. The attenuator has a control range of a nominal 20 dB with quick response and excellent linearity. The SSIPA is designed to be transparent to final amplifier RF parameters. As a result, the overall J Series CMPA gain is specified to be stable within ± 0.25 dB/24 hours with $\pm 10\%$ line voltage variations. The output of the SSIPA is then fed to the input of the TWT. The SSIPA and TWT provide a combined subsystem gain of at least 54 dB at rated power.

The primary TWT employed in this power amplifier is the CPI, VTL-6242S1. This TWT is an efficient design featuring conduction cooling and Periodic Permanent Magnet (PPM) focused helix design.

The output coaxial cable connects the TWT output to the dual directional coupler DC1. The dual port directional coupler provides one reflected power port coupled via a detector to the RF power monitor assembly for reverse power protection, and a forward power port. The forward power sample is split into two via a low power –10 dB coupler DC2 so that a –40 dB and –50 dB sample are available. The –50 dB sample is cabled to a type ‘N’ connector J9 on the front panel for the user to monitor forward RF power. This RF sample port, is calibrated in coupling ratio versus frequency and permits independent monitoring of J Series CMPA output power levels through the use of an external spectrum analyzer or portable power meter. The –40 dB sample is isolated via a DC block and further attenuated 30 dB by AT4 and then detected by CR1 for the front panel forward power metering circuit A7. The reflected power port of DC1 is isolated by DC block FL2, then attenuated approximately 23 dB by AT3 and AT5, and is then detected by CR2. The detected DC output is sent to RF monitor CCA A7 for monitoring of reflected RF power from the load back to the J Series CMPA. Reflected power information is sent to the front panel for display.

The output and reflected power level readouts are also available for remote monitoring via the optional CPI remote panel or the computer interface (CIF) port located on the rear panel. RF drive is adjustable via these ports as well. The standard RF output of the J Series CMPA is a female type N connector.

Soft-Fail Reflected Power Protection

High reflected soft-fail RF protection is a standard feature in the J Series CMPA. This protects the tube from abnormal or transient load conditions which could permanently damage the TWT, while assuring that the maximum RF output power is available without shut-down during a crucial test sequence. In operation, this feature actively reduces the RF output to keep the reflected power below the reflected power trip point, with a factory setting of 25W trip level, reflect power will be limited to around 22W via the CMPA controller by reducing RF gain. Once the reflected power drops below 17W, soft-fail ends and normal operation is restored. User settable low and high RF power alarms via the front panel are controlled via remote panel, computer interface serial or IEEE-488 ports on the rear panel.

Power Supply Subsystem

Overview

The power supply portion of the J Series CMPA provides all of the internal voltages necessary to operate the TWT, RF driver (IPA), and auxiliary circuits for control, monitoring and protection of the J Series CMPA. Only the AC input power is required for operation. The travelling wave tube derives its operation from three DC power supplies: a filament heater low voltage supply, a helix high voltage supply, and a collector high voltage supply. The power supply design utilized in the VZL-6943J2 series CMPA is of the switch mode power conditioner (SMPC) type which has an excellent reputation for reliability and stability. An added advantage of the SMPC approach over outdated linear power supplies is its intrinsic high efficiency and safe operation. By limiting the amount of the instantaneous stored energy in the power supply, the risk of permanent damage to the J Series CMPA due to abnormal or transient conditions is avoided. The momentary level of stored energy (measured in joules) is well below the maximum limit of energy that the tube can safely dissipate during normal operation. A simplified block diagram of the power supply is shown in Figure 3 on the previous page. The principal circuit modules are discussed in the following paragraphs.

Power Factor Correction Module

Input primary power (single phase, 208-240 VAC, $\pm 10\%$, 47/63 Hz) flows via an EMI filter and the main circuit breaker to both the cooling system blower and the Power Factor Correction Module. This module provides a regulated 375 VDC to the Power Processor and allows the J Series CMPA to meet the requirements of EN60555-2 regarding total harmonic distortion. In the event of a failure of this module, a DC bus fault flag is sent to the micro-controller for proper fault handling and display.

Power Processor Module

The power processor circuits provide the necessary line and load regulation of the input 375 volt DC bus, which is converted via a switch regulator and bridge circuit to a nominal 200 volt, 25 kHz to drive the high voltage module. A sample of the helix high voltage output is returned to the switch regulator for error feedback correction and sends a pulse-width modulated signal through an optical isolator to the switching transistors. This approach allows careful regulation of the TWT helix and collector voltages and protects both supplies from over voltage/under voltage or short circuit conditions. Low voltage outputs are also produced by this assembly (+5V, +5 isolated, +16V, $\pm 15V$) which are used to operate various internal circuit functions as well as provide power for the RF monitor circuit, micro-controller assembly, front panel display, and IPA. Internal sensors provide the necessary over-current protection functions for these supplies.

High Voltage Module

The high voltage module provides the following key power supply functions: regulated TWT heater supply, regulated TWT high voltage helix and collector supplies, helix supply current/voltage monitoring and fault protection. The high voltage module contains the transformers, rectifiers, filters and voltage/current sense resistors for critical TWT voltages. The incoming 200 volt, 25 kHz signal is applied to the primary of a multi-section high voltage transformer, which provides all of the high voltage levels necessary to operate the traveling wave tube. The TWT helix and collector share the

same transformer and regulator and operate from the same voltage. A separate step-down transformer with rectifier and filter network is employed to provide the heater voltage.

Control and Display Modules

The microprocessor based monitor and control system is designed to assure proper operation of the power amplifier and easy maintainability with minimal operator training and activity. The microprocessor based monitor and control system includes three parts: a main controller board, an interface board and keyboard/vacuum fluorescent display. The system provides required operational sequencing and monitoring of critical parameters. If a fault should occur, the unit either recycles back to its state prior to the fault or latches into the FAULT state. In either case, the front panel display will provide fault information; also, the user can consult the Fault Log for time/date stamped fault information.

To make most software updates easier to install, the J Series CMPA features Flash RAM based program instructions. A flash RAM is a memory device with the two best characteristics of a disk drive - non-volatile memory and read/write capability. Software upgrades are easy to install in a Flash RAM based J Series CMPA because the upgrade consists of connecting a PC to the J Series CMPA, then executing a PC program. In about two and half minutes the transfer is complete. To enhance the reliability of this approach, a backup version of the J Series CMPA's software exists in an EPROM. This version is not updated (nor can it be via the auxiliary serial port) when the Flash RAM contents are updated. If the Flash RAM contents are corrupted, the J Series CMPA can use the EPROM based program. Also, when the J Series CMPA is powered up, the user may force the J Series CMPA to use the EPROM based program.

Figure 4 and the Product Specifications below present a complete list of controls, displays, and LED indicators on the front panels.

When control power is turned on, the microprocessor self-tests all internal functions and starts HTD (Heater Time Delay). Once the HTD is completed, the STANDBY indicator illuminates to tell the operator that the high voltage may be applied. Depressing the TRANSMIT key initiates the BONS (Beam On Sequence). At the successful conclusion of BONS, the unit is in the TRANSMIT state (high voltage is on). Alternatively, the operator may depress the TRANSMIT key during HTD causing TX SELECT to be displayed on the front panel. In this case, the BONS is initiated automatically at the completion of HTD.

In the event of AC prime power interruptions, the power supply will automatically recycle when the AC power is reapplied. If the loss of power is less than a few seconds, the amplifier will return immediately to its previous state. If the outage is of longer duration, a proportional HTD is performed before returning to the previous state. The longest HTD is three minutes.

If a fault occurs during any normal operating state (the following text will use TRANSMIT as an example), the FAULT LED will light and the unit will switch from TRANSMIT to FAULT. Two scenarios are possible.

The first scenario occurs when fewer than three faults occur within twenty seconds. In this case, the unit will recycle back to TRANSMIT. Each fault will generate a recycle. Each recycle from FAULT to TRANSMIT will be delayed by one second.

The second scenario occurs when at least three faults occur within twenty seconds. In this case the unit will be latched into FAULT and the FAULT LED will flash. To reset the unit for normal operation, clear the source of the fault. Then, press CANCEL. If the fault was successfully cleared, the FAULT LED will extinguish and the unit will be in STANDBY. Press TRANSMIT to resume transmitting.

In either case, the time/date stamped Fault Log will capture each fault event. If multiple faults were detected during one event, they will be listed together. This allows the able user or technician to identify individual faults to a specific module or subassembly.

RF Power Monitor Module

The RF power monitor assembly receives signals from the forward and reflected power RF detectors for use in fault/alarm sensing and forward power metering. The reflected RF fault sensor and the microprocessor based controller protects the TWT against excessive reflected power due to abnormal external load or antenna conditions. The power meter circuits measure and display continuous-wave (CW) RF output. Another RF metering feature is a forward low RF alarm. The output power is compared with a user-settable low RF set point; an alarm is triggered should output power fall below this level.

Mechanical Design

The VZL-6943J2 series CMPA is packaged in a standard rack mounted drawer measuring 19" wide by 8.75" high and 26" deep (plus connectors, fan and air duct adapters). The unit is cooled via an internal forced air cooling system consisting of one AC blower, an air filter and an exhaust duct. Allowances are made for 0.25" H₂O drop due to customer external ducting losses.

LRU Philosophy

The J Series CMPA utilizes a modular design approach incorporating LRUs for ease of maintainability in the field. The maintenance concept employed in the VZL-6943J2 series CMPA is to localize a malfunction or circuit failure down to the level of an LRU, extract the LRU and replace with an equivalent part provided in the spares kit. This procedure can be completed in the field without resorting to the costly practice of returning the entire J Series CMPA to the depot for servicing. The philosophy is to configure the J Series CMPA LRUs as building blocks with a specific function that can be monitored by sensors and fault indicators on a real-time basis.

PRODUCT SPECIFICATIONS

The following specification limits and characteristics apply to the VZL-6943J2 L-Band J Series CMPA unless otherwise specified.

Electrical

Frequency	1.0 – 2.5 GHz
Output Power	
•TWT	54.0 dBm min. (250 Watts min.)
•flange	225 Watts min.
Bandwidth, Instantaneous	1500 MHz
Gain	
•at rated power	54 dB min.
•small signal	56 dB min.
RF Level Adjust Range	0 to 20 dB (via electronic Attenuator)
Output Power Settability	±0.1 dB
Gain Stability	
•at constant drive & temperature	±0.25 dB/24 hr max.(after 30 min. warm-up)
•over temperature, const. dr. (any frequency)	±1.0 dB over oper. temp. range (typical)
Small Signal Gain Variation	
•across the 1500 MHz band	18 dB pk-pk typical.
VSWR	
•Input	2.5:1 max., 2.0:1 max. with optional input isolator
•Output	2.5:1 typical.
Load VSWR	
•full spec compliance	1.5:1 max.
•operation without damage	any value
•continuous operation	2.0:1 max at full power output, higher at lower output powers due to soft-fail protection feature
Residual AM	
•below 10 kHz	-50 dBc
•10 to 500 kHz	-20 (1.3+logF kHz) dBc
•above 500 kHz	-85 dBc
Phase Noise	
•IESS 308/309 phase noise profile	-3 dB
Harmonic Output	-3 dBc typical at lower band edge, decreasing to -15 dBc at high band edge
Noise and Spurious	<-60 dBw/4 kHz
Noise Figure	15 dB max
Primary Power	single phase, 208-240 VAC ±10%, 47-63 Hz

Electrical (Cont)

Power Factor	0.95 min. (meets requirements of EN-60555-2 total harmonic distortion)
Power Consumption	2.6 kVA (typical), 3.0 kVA (max.)
Inrush Current	200% max.

Environmental

Ambient Temperature	
•operating	-10° to +40°C
•non-operating	-40° to +70°C
Relative Humidity	95% non-condensing
Altitude	
•operating	10,000 ft., w/ standard adiabatic derating of 2°C/1,000 ft.
•non-operating	50,000 ft.
Shock and Vibration	As normally encountered in a protected engineering laboratory environment

Mechanical

Cooling	Forced air w/integral blowers. Rear intake and exhaust. Maximum external pressure loss allowable: 0.25 inches water column.
RF Input Connection	Type N Female
RF Output Connection	Type N Female
RF Output Monitor	Type N Female
Dimensions, (W x H x D)	19 x 8.75 x 26 in. (483 x 222 x 661 mm)
Weight	95 lbs (43 kg) max.

Heat and Acoustic

Heat Dissipation	2,300 Watts max.
Acoustic Noise	65 dBA (as measured at 3 ft.)

Characteristics and performance limits are based on current data and are subject to change without notice. Please contact CPI Satcom Division before using this information for system design.

Front Panel Monitors and Controls

Control Functions	Main Power On/Off TX (Transmit) Select Transmit (Beam On) Standby (Beam Off) Local/Remote/Computer (CIF) Select RF Power Setting Automatic Leveling Control (ALC) Attenuator Setting RF Inhibit RF Switch Port Relay Preferences Indicator Test Fault Reset Fault Settings Remote Port Settings/Tests CIF Port Settings/Tests Time date Settings Power Supply Test Mode
Monitoring	RF Output Power (Watts, dBW or dBm) Attenuator Setting RF Reflected Power (Watts, dBW or dBm) RF Output Sample Port (-50 dB nominal, Type N female) Helix Current (mA) Helix Voltage (kV) Beam Current (mA) Heater Elapsed Time Meter Beam On Elapsed Time Meter
Status Display	Power On Heater Time Delay (HTD) TX (Transmit) Select Standby Transmit (Beam On) Local/Remote/CIF ALC Time RF Inhibit w/source

Front Panel Monitors and Controls (Cont)

Fault/Alarm Display	Fault Fault Log Low RF Fault and Alarm High RF Fault and Alarm High Reflected Power Interlocks Open (power supply temp. or amplifier cover) Helix Over Current Helix Over Voltage Helix Under Voltage Power Supply Arc DC Buss Fault TWT Over Temperature Fault Fault External Interlocks Fault
---------------------	--

Remote Control Interface

Control Functions	TX (Transmit) Select Transmit (Beam On) Standby (Beam Off) Remote/Computer (CIF) Select RF Power Setting Automatic Leveling Control (ALC) Attenuator Setting RF Inhibit RF Switch Port Relay Preferences Indicator Test Fault Reset Fault Settings CIF Port Setting/Tests Time Date Settings
Monitoring	RF Output Power (Watts, dBW or dBm) Attenuator Setting RF Reflected Power (Watts, dBW or dBm) Helix Current (mA) Helix Voltage (kV) Beam Current (mA) Heater Elapsed Time Meter Beam On Elapsed Time Meter

Remote Control Interface (Cont)

Status Display	Heater Time Delay (HTD) TX (Transmit) Select Standby Transmit (Beam On) Local/Remote/CIF ALC Time RF Inhibit w/source
Fault/Alarm Display	Fault Fault Log Low RF Fault and Alarm High RF Fault and Alarm High Reflected Power Interlocks Open (power supply temp. or amplifier cover) Helix Over Current Helix Over Voltage Helix Under Voltage Power Supply Arc DC Buss Fault TWT Over Temperature Fault External Interlocks Fault

Computer Serial and IEEE-488 Interfaces

Control Functions	TX (Transmit) Select Transmit (Beam On) Standby (Beam Off) RF Power Setting Automatic Leveling Control (ALC) Attenuator Setting RF Inhibit Fault Reset RF Alarm/Fault Settings Monitoring RF Output Power (Watts and dBW) Attenuator Setting RF Reflected Power (Watts and dBW) Helix Current (mA) Helix Voltage (kA) Beam Current (mA) Heater Elapsed Time Meter Beam On Elapsed Time Meter
-------------------	---

Computer Serial and IEEE-488 Interfaces (Cont)

Status Display

Heater Time Delay (HTD)
TX (Transmit) Select
Standby
Transmit (Beam On)
Local/Remote/CIF
ALC
RF Inhibit w/source

Fault/Alarm Display

Fault
Low RF Fault and Alarm
High RF Fault and Alarm
High Reflected Power
Interlocks Open (power supply temp. or amplifier cover)
Helix Over Current
Helix Over Voltage
Helix Under Voltage
Power Supply Arc
DC Buss Fault
TWT Over-temperature Fault
External Interlocks Fault

RF Switch Port Interface

Features

RF Inhibit Command
Low RF Relay
Fault Relay (can be reassigned)
Sum Fault Relay

External Interlock Interface

Features

External Interlocks Latching (User Induced Fault)
External Interlocks Non-Latching (RF Inhibit)

Options & Features

Features

- Soft-Fail Reflected Power Protection
- Alpha-numeric Menu-driven 4-line display on front panel
- Meets EN 61010 and EN60555-2 Safety/Harmonic standards as well as EEC 89/336 EMC standards
- Filament voltage reduction of 10% in standby
- IEEE-488 and RS422/485 (4 wire) computer interface standard
- Auto Fault Recycle (except for Power Supply Arc and External Interlocks)
- Internal test points for ease of maintenance
- MTTR < 1 hr
- Forward power metering
- Electronic RF Attenuator standard

Options

- Remote Control Panel
- Redundant and Power Combined Systems
- RF Input Isolator option is available to reduce the input VSWR to the lowest possible level.
- 115 VAC external step-up transformer option. This is used where 220-240 VAC input power is not available.

- Also available in 250 W S/C and M-Band Models

ACCESSORIES

Several optional accessory items have been designed for use with the CPI 250 W L-band J Series CMPAs. Brief descriptions of the items now available are given on the following paragraphs.

Redundant Switching

The Switching System consists of an output switch, dummy load and local control unit. These assemblies are usually mounted on the upper part of a rack/cabinet intended to house the two J Series CMPAs. The circuit provides 1:1 redundant protection with automatic transfer, or manual operation (local or remote) as selected by the operator. Options are available for the addition of an input power divider or a ganged input transfer switch.

Phase Combining

The Phase Combiner consists of a coaxial input divider network and phase shifter and an output combining system, to coherently combine the output RF power of two J Series CMPAs. The combined system then behaves as a single power amplifier with nearly twice the RF output power of a single J Series CMPA. The combiner is a hybrid coupler, which combines the two inputs with minimum loss.

The combiner assembly is normally supplied mounted in the rack/cabinet which also houses the two J Series CMPAs to provide an integrated power-combined J Series CMPA system.

Remote Control Panels

The Remote Control/Monitor panel is a rack-mountable unit 3.5 inches high that provides an output RF power meter and all of the remote controls and indicators listed in this brochure. The panel requires a source of AC power and it does not include the interconnect cable from the J Series CMPA. The ideal interconnect cable would include two twisted pairs enclosed in a shield; several wire manufacturers build cable specifically for RS-422/485 applications. Since the RS-422/485 serial format is used, cable lengths are limited to 4,000 feet.

Remote control/monitor panels are also available for use with the switching system and phase combiner systems.

L-Band J-Rack 1.0 - 2.5 GHz Typical Test Data

Gain and Output Power

Frequency (GHz)	Sat. Power Out (dBm)	Gain at Rated Power (dB)
1.0	56.0	76.4
1.5	55.9	81.2
1.75	56.1	80.3
2.0	56.3	77.8
2.5	56.5	65.2

Swept Gain Response: See Figure 3

Input VSWR: 2.46:1

Output VSWR: 2.00:1

SSG Variation: 17.82 dB p-p max.

Phase Noise: 36.5 dBc

Noise Figure: +6.7 dB

Noise Density: -80.1 dBw/4 kHz

Harmonic Output (GHz)

- 1.0 -5.90 dBc
- 1.5 -10.60 dBc
- 1.75 -13.60 dBc
- 2.0 -21.80 dBc

Residual AM

Rated Power

- 0 10 kHz 75 dBc (See Figure 4)
- 10 500 kHz 69 dBc (See Figure 5)
- 500 kHz 1 MHz 74 dBc (See Figure 6)

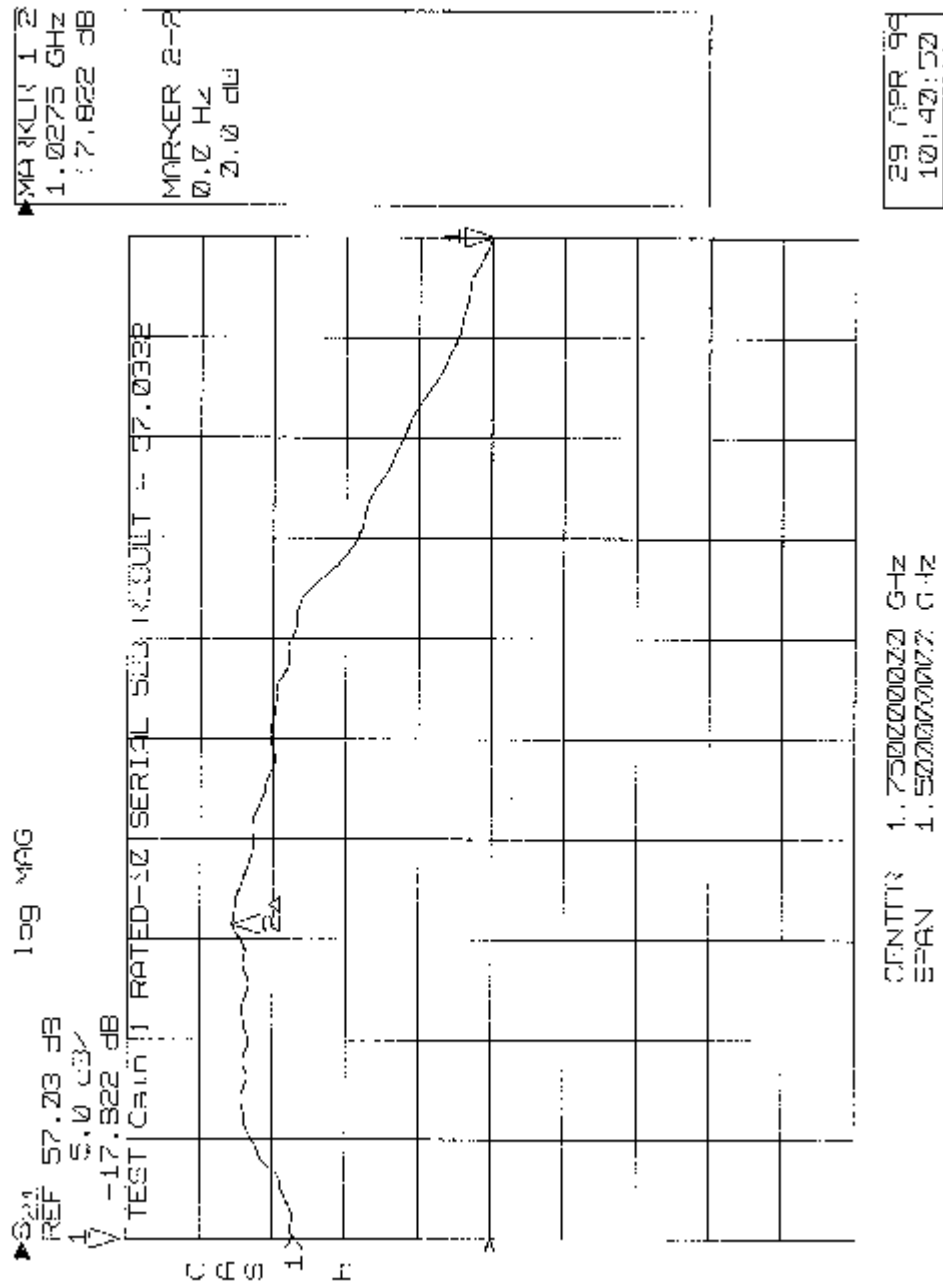

Figure 3. Small Signal Gain



Figure 4. Residual AM 0 kHz to 10 kHz



Figure 5. Residual AM 10 kHz to 50 kHz



Figure 6. Residual AM 50 kHz to 100 kHz

SUPPORT SERVICES

Documentation

CPI Satcom Division provides a commercial documentation package for all products. The content of this package is determined by the nature of the product concerned, and the quantity is governed by contractual requirements. The standard package for Satcom power amplifiers includes a comprehensive Operation and Maintenance Manual, outline and interface drawings, Manufacturing Test Report and spare parts lists. Outline and interface drawings provide dimensions and the location and size of mounting holes, duct work, and waveguide, so that site preparations can be accomplished prior to receipt of the equipment.

The Service Manual provides instruction for unpacking and installation, initial set-up, calibration, normal operation, maintenance and repair of the equipment. The manual includes schematic diagrams, block diagrams, and wiring information sufficient for use by maintenance personnel.

The Acceptance Test Report outlines the test performed limits established. Space is provided on the test report for recording and certifying the test results, consolidating all related information in one document. The spare parts documentation consists of a recommended spare parts list to support the equipment for a one-to-two year period of operation. A CSI Acceptance Test can be performed at customer's option which will repeat and verify results of selected performance tests that were already recorded in the standard acceptance test.

Training

CPI Satcom Division is prepared to conduct training courses covering the installation, operation and maintenance of its equipment. The training course on high power amplifiers consists of lectures using training material, such as technical manuals and drawings, plus actual operation and adjustments demonstrated on the equipment.

Small training groups (up to five students) assure the customer that each student has an opportunity to participate fully in demonstration activities. Courses may be conducted at the CPI factory or on-site. Course duration varies from several days to one or two weeks, depending on the scope of work agreed upon and the skill level of the students.

Field Service

The product support activity of CPI includes a staff of experienced, professional service technicians to assist users in maintaining full performance from their CPI power amplifiers. A telephone "hot line" permits access to one of these technicians on a 24-hour per day basis. Operational problems often can be diagnosed, corrective action prescribed, and normal operation restored through such telephone consultation. When called for, however, the service technicians are prepared to give on-site assistance.

Product Support carries an large inventory of spare parts that can be made ready for shipment within 24 hours. Coupled with a dedicated dial-in telephone line, this service is effective in aiding users to restore equipment to operational status with minimum downtime. Technical assistance and factory approved replacement parts are also available at strategically located Regional Service Centers in the U.S.A., Europe and the Pacific Rim.