

Test Instrumentation Range



Comparison Noise Emitters
(CNEs) Broadband Noise Signal Source



Comb Generator Emitters
(CGEs) Reference Signal Source



York Reference Sources
(YRSs) Dual Comb and Broadband
Noise Emitters



Antennas, Harmonics & Flicker
Active Receive Antenna, Cable Coupling
Clamps, Accessories

About York EMC Services

Your Smart Route to Compliance

York EMC Services (YES) is an independent organisation with over 25 years experience providing regulatory and compliance consultancy, compliance testing, certification, training and instrumentation. We operate within the UK from four sites which includes three UKAS accredited test laboratories and our headquarters in York. Our Test Instrumentation is sold through a worldwide network of Distributors.

Our service portfolio covers:

- EMC and electrical safety testing
- Radio and telecoms testing
- Electromagnetic site surveys
- EMC, Radio and Safety Consultancy and Research
- Electromagnetic modelling
- Training

Our instrumentation portfolio covers:

- Broadband reference sources
 - Dual mode comb / noise generators
 - Comb generators
 - Noise generators
- Harmonics and flicker generators
- Compact wideband antenna
- Cable coupling clamp



Commitment to Quality

YES is committed to providing the highest quality services in all our service areas by fully understanding and meeting the customer's expectations in a timely and cost effective manner.

YES customers can be assured that it is our intention to provide technical support and products of the highest calibre, delivered professionally in an accessible and friendly way.

All of our services are within the scope of our quality system and accredited to ISO 17025 or ISO 9001 as appropriate.



Instrumentation, Consultancy and Research, Training

What our customers say...

“ We recently ran some in house EMC appreciation training for our staff, with YES as the training provider. They were most helpful in setting up the subject and content of the courses. Given that the attendance ranged from senior managers, through designers to installers YES did an excellent job in the presentation and demonstration. ”

Systems Engineer,
Signalling Solutions

“ Being my first time testing at an external EMC test house, the help and guidance provided by York EMC Services on both the test procedures and correct use of equipment was very welcome. Also, the flexibility to fit in our testing at very short notice, on numerous occasions, was a massive help to be able to achieve our project delivery milestones. ”

Electronics NPI Engineer,
Knorr-Bremse Rail Systems

“ We have built a really good working relationship with the York EMC team over the last few years, in particular with the Castleford laboratory. The support they offer is fantastic and we really appreciated the great job they do, sometimes at very short notice. ”

Technical Manager,
Ferrograph

Contents

Introduction

| | |
|---|---|
| Reference, Noise and Signal Sources | 4 |
| Harmonics and Flicker Test Signal Sources | 4 |
| Emissions Measurement Antenna | 4 |
| Cable Shielding Measurement Clamp | 4 |
| Applications Matrix | 5 |
| Product Overview | 5 |

Product Technical Information

| | |
|---|----|
| CNE V/V+ – Comparison Noise Emitter | 6 |
| CNE VI – Comparison Noise Emitter | 10 |
| CGE01 – Comb Generator Emitter | 14 |
| CGE02 – Comb Generator Emitter | 18 |
| CGE03 – Comb Generator Emitter | 21 |
| YRS01 – Hybrid Comb and Noise Source | 23 |
| YRS02 – Hybrid Comb and Noise Source | 28 |
| YRS03 – Hybrid Comb and Noise Source | 33 |
| ARA 01 – Active Receive Antenna | 38 |
| HFG01 – Harmonics and Flicker Generator | 40 |
| HFG02 – Harmonics and Flicker Generator | 42 |
| CCC01 – Cable Coupling Clamp | 46 |

How To ...

| | |
|---|----|
| Pre-test checks how and why? | 48 |
| How to use a Comparison Noise Emitter (CNE) to check Line Impedance Stabilisation Network (LISN) performance | 52 |
| How to use a Harmonics and Flicker Generator (HFG) to check harmonics and flicker test setup | 54 |
| How to use a Comparison Noise Emitter (CNE) to measure filter response | 57 |
| How to convert dB μ V/m test results into Effective Isotropic Radiated Power (EIRP) | 60 |
| How to use a Cable Coupling Clamp (CCC01) to measure cable shielding effectiveness through transfer impedance | 61 |

Glossary

General Information

Overview of Products and Specifications

Overview of Product Accessories

| |
|----|
| 64 |
| 65 |
| 66 |
| 68 |

Introduction

How do you know that the test results from your EMC measurement systems are correct? How can you be sure that different test facilities on different sites are yielding the same results? You've designed a notch filter but need to check its characteristics. Your laboratory needs to comply with ISO 17025 and you find that you are required to carry out regular validation and verification checks on each of your test systems.

One of your products is failing radiated RF emissions tests and you need to be able to measure the effectiveness of the EM shielding. In all of these cases investigation will require the use of a known, stable signal to inject into the system to carry out measurements. A York EMC Services broadband reference signal source will allow you to start your work from the point of knowing that the noise or signal source is defined and stable.



Reference Noise and Signal Sources

York EMC Services, based in York, UK, are world leaders in the design and manufacture of reference signal sources for Electromagnetic Compatibility (EMC) and other applications. Offering outputs which are highly stable over time and temperature, and frequencies up to 40 GHz, these products provide a known reference output with which to characterise the performance of systems including: EMC test and measurement systems, measurement environments, screened rooms, anechoic chambers, open area test sites, filters, cables, connectors, amplifiers, receivers and spectrum analysers, as well as for measuring the shielding effectiveness of enclosures and materials. The availability of both conducting and radiating output versions enhances this broad range of uses.

Uniquely, York EMC Services offers both continuous noise reference signal sources, known as comparison noise emitters (CNE), and the more common harmonic comb spectrum reference signal sources, known as comb generator emitters (CGE). The former provide a continuous, broadband output across their operating frequency range which allows for a more complete evaluation of the characteristics of the equipment being analysed without any gaps in the spectrum. York EMC Services' CNEs cover 30 Hz to 6 GHz.

Comb generators are more appropriate for higher frequencies where the energy is concentrated in discrete harmonics of the step size frequency. Using this technology enables the frequency range to be extended to 40 GHz. In addition, the York Reference Sources (YRS) produce both noise and comb signal outputs, providing a flexible solution to a range of test requirements.

All the reference sources are physically small and battery powered, allowing them to be used in a wide range of situations without requiring external power sources or cabling.

The CNE range has become an industry standard and have been used as reference sources to carry out inter-site comparisons between measurement environments in national and international studies by, amongst others, the National Physical Laboratory, the United Kingdom Accreditation Service and FOR-EMC. Studies have also been carried out in the UK, the USA and Europe.

These noise and comb signal sources have been designed to radiate at radio frequencies and should only be operated in a managed electromagnetic environment providing adequate isolation in the frequency range of the instrument in use. Examples of environments providing such attenuation would include screened rooms, anechoic and semi anechoic rooms, RF shielding enclosures, or open test sites with sufficient distance between the noise or signal source and any potentially vulnerable equipment.

Harmonics and Flicker Test Signal Sources

IEC 61000-3-2 and IEC 61000-3-3 and the EN equivalents, require harmonics and flicker measurements to be carried out on equipment. The measurement equipment needs to be periodically verified just as for RF measurements. York EMC Services has developed the HFG01 and HFG02 as reliable harmonics/flicker load generators for this purpose.

Emissions Measurement Antenna

York EMC Services has also recognised the need to perform radiated emission measurements using a physically compact antenna. The ARA 01 is an active, receive only antenna with an antenna factor comparable to the "Bilog™" and other commercially available wideband antennas operating between 30 MHz and 1 GHz.

Cable Shielding Measurement Clamp

A Cable Coupling Clamp (CCC01) based on the launcher described in IEC 96-1 Amendment 2 1993-06 section A.5.6 Line Injection Method (frequency domain) is available. This allows coupling and shielding effectiveness measurements to be made on a range of cable types.

Applications Matrix

| | YRS01 | YRS02 | YRS03 | CNE V CNE V+ | CNEVI | CGE01 | CGE02 | CGE03 | ARA 01 | HFG01 | HFG02 |
|---|-------|-------|-------|-----------------|-------|-------|-------|-------|--------|-------|-------|
| Pretest checks | ● | ● | ● | ● | ● | ● | ● | ● | ● | ● | ● |
| Long term performance monitoring | ● | ● | ● | ● | ● | ● | ● | ● | | ● | ● |
| Measurement environment comparison | ● | ● | ● | ● | ● | ● | ● | ● | ● | | |
| OATS, FAR, screened room characterisation | ● | ● | ● | ● | ● | ● | ● | ● | ● | | |
| Reverberation (mode stirred) chamber characterisation | | | | | | ● | ● | ● | | | |
| Filter performance analysis | ● | ● | ● | ● | ● | ● | ● | ● | | | |
| Cable/connector loss analysis | ● | ● | ● | ● | ● | ● | ● | ● | | | |
| Shielding effectiveness measurements | ● | ● | ● | | | ● | ● | ● | ● | | |
| Confined space/portable measurements | ● | ● | ● | ● | ● | ● | ● | ● | ● | | |
| Low cost, compact, wideband antenna | | | | | | | | | ● | | |
| Inter-laboratory test program | ● | ● | ● | ● | ● | ● | ● | ● | | ● | ● |
| Proficiency test program | ● | ● | ● | ● | ● | ● | ● | ● | | ● | ● |

Product Overview

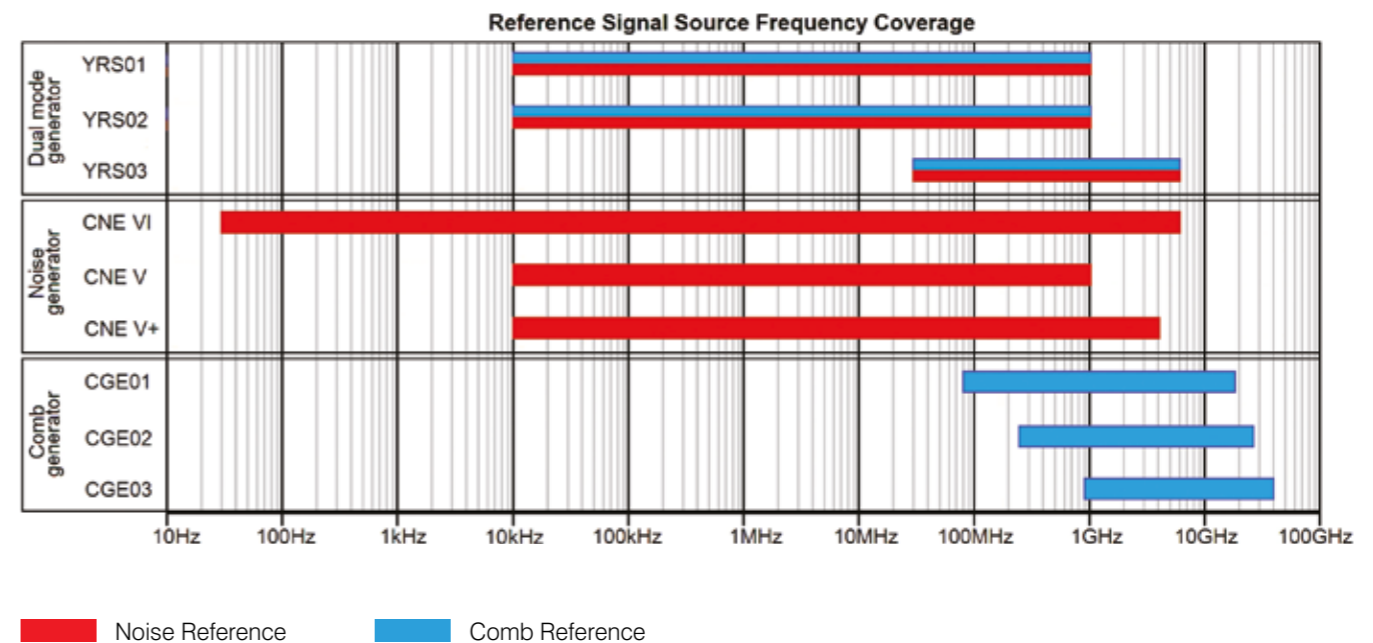

Product Technical Information

Comparison Noise Emitter: CNE V/ V+

The Comparison Noise Emitter V (CNE V) is a low-cost broadband noise source providing a continuous output from 9 kHz to 1 GHz. The stable output allows the CNE V to be used as a general-purpose reference source for characterising and verifying both conducted and radiated test environments.

The Comparison Noise Emitter V+ (CNE V+) is an enhanced version of the low cost CNE V broadband noise source, providing an extended, continuous output from 9 kHz to 3.5 GHz with a usable output to 5 GHz.

The broadband nature of the output enables the observation of details within the spectrum that would be missed when using a comb generator, whilst the power output level of the unit avoids the overloads possible with impulsive noise sources that may cause damage to the sensitive input circuits of receiving equipment.

The CNE V is supplied with a 50 Ω BNC-type output connector for direct connection to conducted measurement systems. An IEC 320 adapter is also available to provide a connection to LISN equipment, as well as an RJ11/RJ14/RJ25/RJ45 adapter for connection to telecoms ISNs.



CNE V+ with TLM01

The CNE V can also be connected to an antenna, to generate reference fields for use with radiated emissions test environments such as Open Area Test Sites and anechoic chambers. A selection of antennas that connect directly to the CNE V for this purpose is available. The CNE V is compact and battery powered to allow operation as an electrically small source at lower frequencies, thereby minimising the effect of the CNE V structure when being used as a radiating reference.

Features

- **Continuous, broadband output**
 - Full spectrum measurements and analysis
- **Stable output**
 - Repeatable measurements
- **Conducted and radiated options**
 - Evaluation of both conducted and radiated systems
- **9 kHz to 1 GHz (CNE V) or 9 kHz to 3.5 GHz (CNE V+) output**
 - Applications across a broad frequency spectrum
- **Compact and portable**
 - Comparisons between sites and environments
- **Battery powered**
 - No power or interconnecting cables affecting measurements
- **Low cost**
 - Affordable confidence in measurement system results

Applications

- **Conducted measurement systems validation and verification**
- **Radiated measurement systems validation and verification**
- **Reference source for:**
 - Daily pre-test verification checks as required by Quality Management Systems e.g. ISO 17025, DEF STAN 59-411
 - Long term performance monitoring
 - Spectrum analyser / receiver pre-checks
 - Cable position investigation
- **Investigation of screened room/anechoic room/OATS behaviour**
- **Comparisons between different measurement environments e.g. OATS or anechoic chambers**
- **Characterisation of filter performance**
- **Cable loss measurements**
- **Inter-laboratory test programs**
- **Proficiency test programs**

Manufacturer's calibrations

- CAL01** **Conducted** output power, 9 kHz to 5 GHz, measured using a spectrum analyser (**CNE V+ only**)
- CAL02** **Radiated** field strength, 30 MHz to 1 GHz, measured at 3 m OR 10 m on an OATS using a spectrum analyser or receiver
- CAL03** **Conducted** output power, 9 kHz to 1 GHz, measured using a spectrum analyser (**CNE V only**)
- CAL04** **Radiated** field strength, 30 MHz to 1 GHz, measured at 3 m AND 10 m on an OATS using a spectrum analyser or receiver
- CAL06** **Radiated** field strength, 30 MHz to 1 GHz, measured at 3 m in a FAR using a spectrum analyser or receiver

CNE V Specifications

| | |
|------------------------------|---|
| Frequency range | 9 kHz to 1 GHz direct connection into 50 Ω system 30 MHz to 1 GHz radiated using TLM01 and TLM02 antennas |
| Output connector | 50 Ω BNC-type socket |
| Temperature stability | 9 kHz to 1 GHz, <±1 dB, at an ambient temperature of 15 °C to 30 °C 9 kHz to 1 GHz, <±2 dB, at an ambient temperature of 5 °C to 40 °C |
| Time stability | Typically <1 dB over a 12 month period |
| Dimensions | 120 mm × 120 mm x 41 mm (60 mm including connector) |
| Weight | Approx 0.53 kg (including battery) |
| Power supply | 1 x 9 V battery (PP3 or equivalent). Alkaline or rechargeable NiMH |
| Operating time | 3 hours typical with alkaline batteries |
| Indicators | Power on, low battery |

CNE V+ Specifications

| | |
|------------------------------|---|
| Frequency range | 9 kHz to 3.5 GHz (usable to 5 GHz) into a 50 Ω system 30 MHz to 3.5 GHz radiated using TLM01, TLM02 and MCN03 antennas |
| Output connector | 50 Ω N-type socket |
| Temperature stability | 9 kHz to 3.5 GHz, <±1 dB, at an ambient temperature of 15 °C to 30 °C 9 kHz to 3.5 GHz, <±2 dB, at an ambient temperature of 5 °C to 40 °C |
| Time stability | Typically <1 dB over a 12 month period |
| Dimensions | 120 mm × 120 mm x 41 mm (60 mm including connector) |
| Weight | Approx 0.53 kg (including battery) |
| Power supply | 1 x 9 V battery (PP3 or equivalent). Alkaline or rechargeable NiMH |
| Operating Time | 3 hours typical with alkaline batteries |
| Indicators | Power on, low battery |

Standard kits

| Part Number | Description | Parts included |
|------------------|--|--|
| CNEVKIT01 | Standard CNE V comparison noise emitter kit | <ul style="list-style-type: none"> CNE V noise source TLM01 – 200 MHz to 1 GHz (optimum) 100 mm long top-loaded monopole antenna |
| CNEVKIT02 | Enhanced CNE V comparison noise emitter kit | <ul style="list-style-type: none"> CNE V noise source TLM01 – 200 MHz to 1 GHz (optimum) 100 mm long top-loaded monopole antenna TLM02 – 30 MHz to 300 MHz (optimum) 270 mm long top-loaded monopole antenna LSA03 – LISN adapter with IEC 320 style connector |
| CNEVKIT03 | Standard CNE V+ comparison noise emitter kit | <ul style="list-style-type: none"> CNE V+ noise source TLM01 – 200 MHz to 1 GHz (optimum) 100 mm long top-loaded monopole antenna |
| CNEVKIT04 | Enhanced CNE V+ comparison noise emitter kit | <ul style="list-style-type: none"> CNE V+ noise source TLM01 – 200 MHz to 1 GHz (optimum) 100 mm long top-loaded monopole antenna TLM02 – 30 MHz to 300 MHz (optimum) 270 mm long top-loaded monopole antenna MCN03 – 1 GHz to 3.5 GHz (optimum with CNE V+) monocone antenna LSA03 – LISN adapter with IEC 320 style connector |

All kits are supplied with: Alkaline batteries, hard case, CAL03 – 9 kHz to 1 GHz CNE V output power measurement using spectrum analyser or CAL01 – 9 kHz to 5 GHz CNE V+ output power measurement using a spectrum analyser or receiver, manual.

Accessories

| | |
|--------------|--|
| TLM01 | 200 MHz to 1 GHz (optimum) 100 mm top-loaded monopole antenna |
| TLM02 | 30 MHz to 300 MHz (optimum) 270 mm top-loaded monopole antenna |
| MCN03 | 1 GHz to 6 GHz (optimum) monocone antenna (CNEV+ only) |
| LSA03 | LISN adapter with IEC 320 style connector |
| NIA01 | ISN adapter with RJ11/RJ14/RJ25/RJ45 style connection |
| MON02 | Telescopic rod antenna |

Comparison Noise Emitter: CNE V/ V+ Typical output measurement results

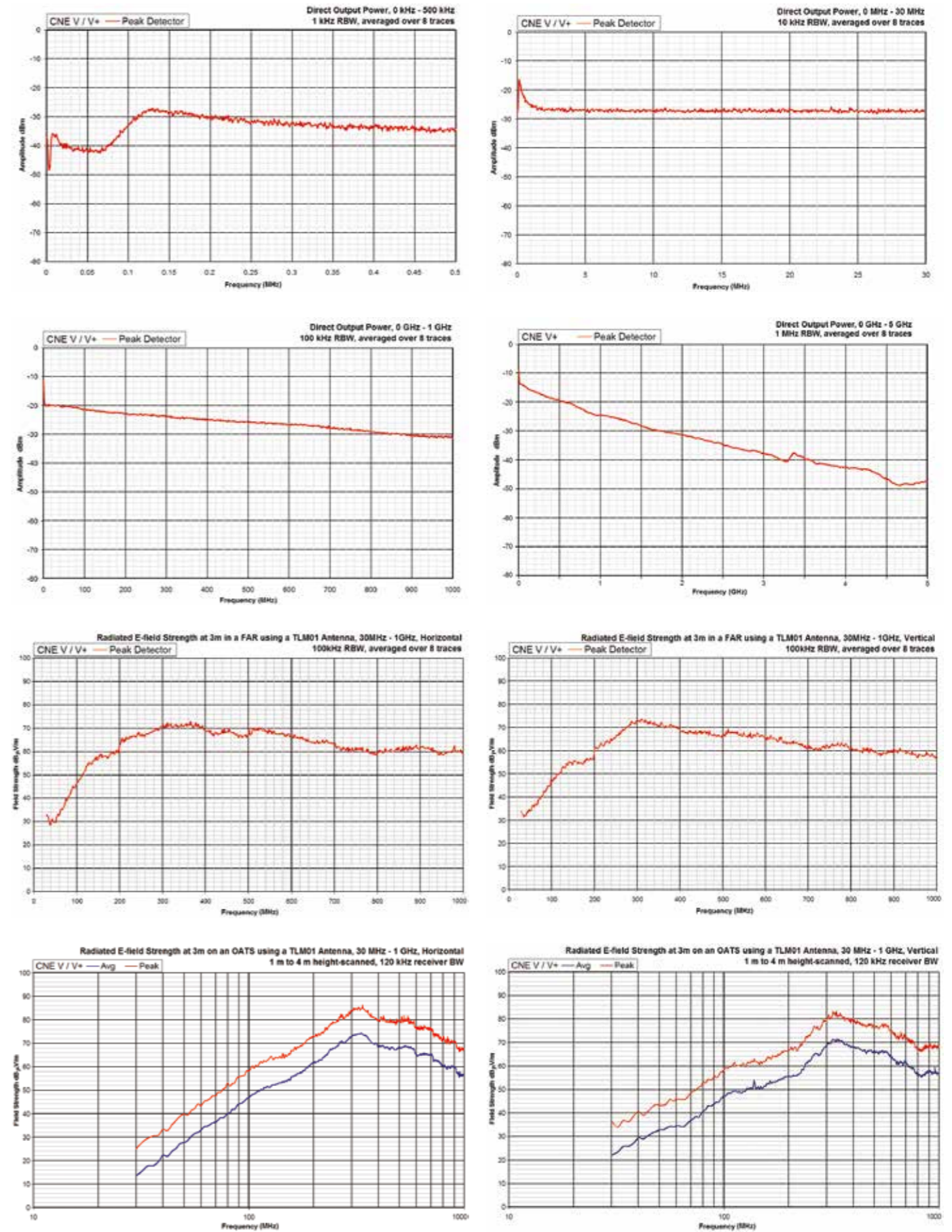

Product Technical Information

Comparison Noise Emitter: CNE VI

The CNE VI is the latest generation broadband noise source, capable of providing a continuous output from 30 Hz to 6 GHz. The stable output allows the CNE VI to be used as a general-purpose reference source for characterising and verifying both conducted and radiated test environments.

The CNE VI is a broadband noise source that is capable of producing a continuous noise output within the 30 Hz to 6 GHz frequency range. The broadband nature of the output enables the observation of details within the spectrum that would be missed using a comb generator.

The CNE VI features two separate outputs; a 50 Ω BNC connector for the 30 Hz to 30 MHz signal and a 50 Ω N-type output connector for the 30 MHz to 6 GHz signal. For radiated operation, either output can be attached to a selection of antennas available in a range of frequency coverage and types. An IEC 320 adapter is also available to provide a connection to LISN equipment, as well as an RJ11/RJ14/RJ25/RJ45 adapter for connection to telecoms ISNs.



CNE VI with MCN03 antenna and LSA03 LISN adapter

The CNE VI is an ideal source for carrying out checks on Open Area Test Sites (OATS) and fully- or semi-anechoic chambers. The CNE VI is compact and battery powered, allowing operation as an electrically small source, which minimises the effect of the CNE VI itself when characterising the electromagnetic environment. The CNE VI is housed in a metal enclosure so that it can be mounted in direct contact with a metal ground plane as may be required by some tests.

Features

- **Continuous, broadband output**
 - Full spectrum measurements and analysis
- **Stable output**
 - Repeatable measurements
- **Conducted and radiated options**
 - Evaluation of both conducted and radiated systems
- **30 Hz to 6 GHz output**
 - Applications across a broad range of frequencies
- **Compact and portable**
 - Comparisons between sites and environments
- **Battery powered**
 - No power or interconnecting cable effects on measurements

Applications

- **Validation and verification of radiated and conducted measurement systems, such as:**
 - Open Area Test Sites (OATS)
 - Fully Anechoic Rooms (FAR)
 - Semi-Anechoic Chambers (SAC)
 - Gigahertz Transverse ElectroMagnetic (GTEM) cells
 - Line Impedance Stabilisation Network (LISN)
 - Impedance Stabilisation Network (ISN)
- **Reference source for:**
 - Daily pre-test checks as required by the accreditation authorities e.g. ISO 17025, DEF STAN 59-411
 - Long-term performance monitoring
 - Cable position investigation
 - Investigation of screened room behaviour
 - Characterisation of filter performance
 - Cable loss measurements
- **Measuring amplifier gain and bandwidth**
- **Spectrum analyser/receiver pre-check**
- **Investigation, characterisation and comparison of different measurement environments such as OATS, FAR or SAC.**
- **Inter-laboratory test programs**
- **Proficiency test programs**

Manufacturer's calibrations

- CAL02** **Radiated** field strength, 30 MHz to 1 GHz, measured at 3 m OR 10 m on an OATS using a spectrum analyser or receiver
- CAL04** **Radiated** field strength, 30 MHz to 1 GHz, measured at 3 m AND 10 m on an OATS using a spectrum analyser or receiver
- CAL06** **Radiated** field strength, 30 MHz to 1 GHz, measured at 3 m in a FAR using a spectrum analyser or receiver
- CAL07** **Radiated** field strength, 1 to 7 GHz, measured at 3 m in a FAR using a spectrum analyser or receiver
- CAL20** **Conducted** output power, 30 Hz to 6 GHz, measured using a spectrum analyser

Specifications: Noise Mode 1

| | |
|------------------------------|---|
| Frequency range | 30 Hz to 30 MHz direct connection into 50 Ω system Up to 30 MHz radiated using a 1 m monopole Up to 30 MHz radiated using loop antennas |
| Output connector | 50 Ω BNC-type socket |
| Temperature stability | < +/-0.5 dB between 30 Hz and 30 MHz, from 5 °C to 40 °C |
| Time stability | <1 dB typical over a 12 month period |
| Operating time | 14 hours typical with alkaline cells |

Specifications: Noise Mode 2

| | |
|------------------------------|---|
| Frequency range | 30 MHz to 6 GHz direct connection into 50 Ω system 30 MHz to 6 GHz radiated using MON03 monopole and MCN03 monocone antennas |
| Output connector | 50 Ω N-type socket |
| Temperature stability | < +/-1 dB between 30 MHz and 6 GHz, from 15 °C to 30 °C < +/-1.5 dB between 30 MHz and 6 GHz, from 5 °C to 40 °C |
| Time stability | <1 dB typical over a 12 month period |
| Operating time | 6.5 hours typical with alkaline cells |

Other

| | |
|---------------------|---|
| Dimensions | 120 mm x 120 mm x 60 mm (140 mm x 140 mm x 79 mm including connectors, switches) |
| Weight | 1 kg (including cells) |
| Power supply | 4 x 1.5 V cells (AA or equivalent). Alkaline or rechargeable NiMH. |
| Indicators | Active, low battery |
| Controls | Rotary switch for mode selection including OFF |

Standard kits

| Part Number | Description | Parts included |
|-------------------|--|---|
| CNEVIKIT01 | Standard CNE VI comparison noise emitter kit | <ul style="list-style-type: none"> • CNE VI noise source • MON03 – 200 MHz to 1 GHz (optimum) 270 mm long monopole antenna • LSA03 – LISN adapter with IEC 320 style connector |
| CNEVIKIT02 | Enhanced CNE VI comparison noise emitter kit | <ul style="list-style-type: none"> • CNE VI noise source • MON03 – 200 MHz to 1 GHz (optimum) 270 mm long monopole antenna • LSA03 – LISN adapter with IEC 320 style connector • TLM02 – 30 MHz to 300 MHz (optimum) 270 mm long top-loaded monopole antenna • MCN03 – 1 GHz to 6 GHz (optimum) monocone antenna |

All kits are supplied with: Alkaline batteries; hard case; manual; CAL20 – 0 GHz to 6 GHz output power measurements in all modes using a spectrum analyser or receiver.

Accessories

| | |
|--------------|---|
| TLM01 | 200 MHz to 1 GHz (optimum) 100 mm long top-loaded monopole antenna |
| TLM02 | 30 MHz to 300 MHz (optimum) 270 mm long top-loaded monopole antenna |
| MCN03 | 1 GHz to 6 GHz (optimum) 120 mm diameter monocone antenna |
| MON02 | Telescopic rod antenna |
| MON03 | 200 MHz to 1 GHz (optimum) 270 mm long monopole antenna |
| LSA03 | LISN adapter with IEC 320 style connector |
| NIA01 | ISN adapter with RJ11/RJ14/RJ25/RJ45 connector |

Comparison Noise Emitter: CNE VI Typical output measurement results

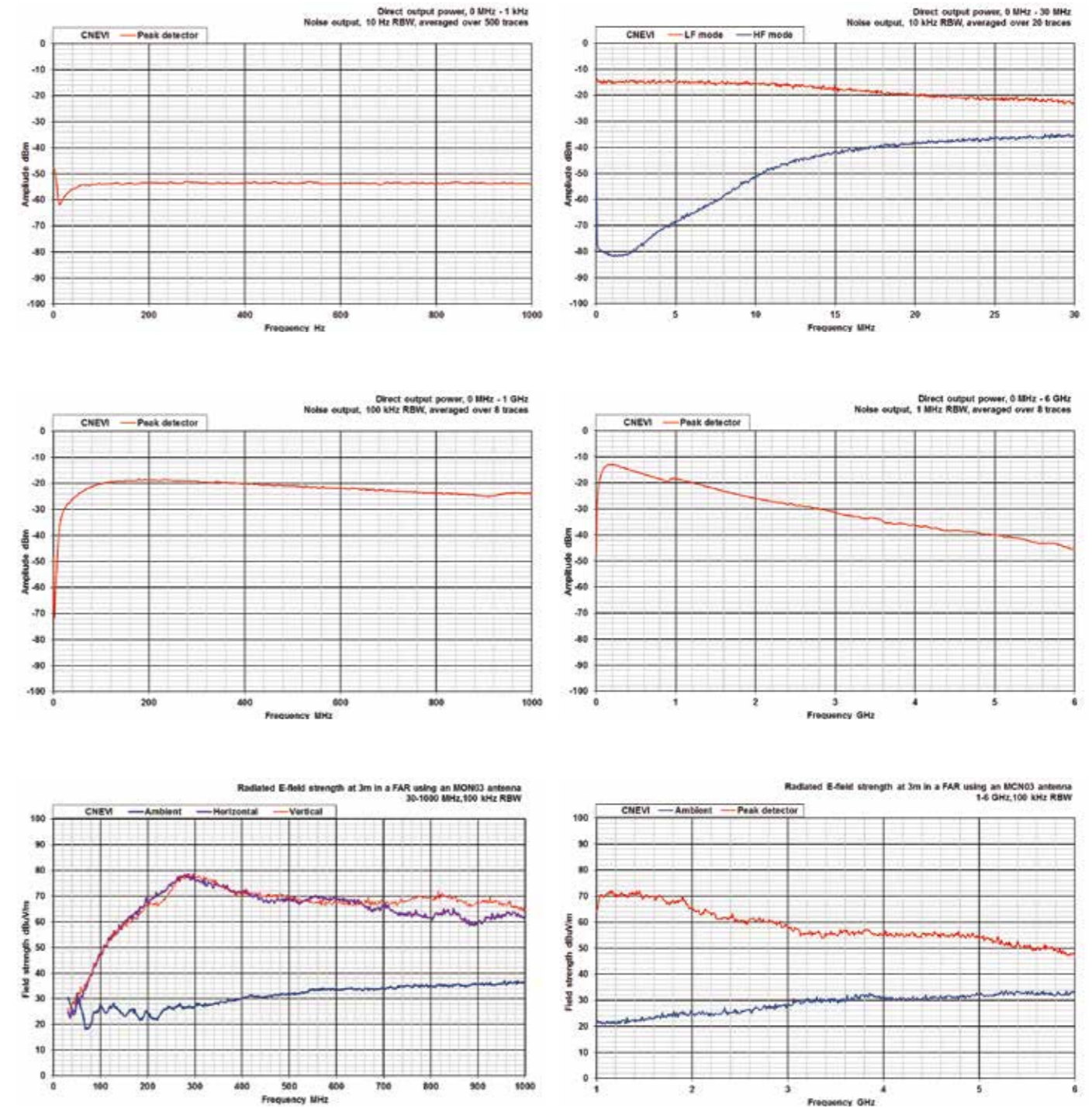

Product Technical Information

Comb Generator Emitter: CGE01

The Comb Generator Emitter 01 (CGE01) is a compact, battery powered, reference signal source that generates a broadband radiated and/or conducted output up to 18 GHz. When used as a verification reference source, the known output allows unknowns within systems or components to be measured or calculated. The compact size allows small enclosures to be evaluated when used as a reference source for shielding effectiveness measurements.

The CGE01 can be supplied with a 50 Ω SMA output connector (CGE01C) for direct connection to conducted test systems, or to an external antenna in order to generate test fields for evaluating radiated emission test systems. Alternatively, to achieve the best repeatability and compactness for purely radiated applications, the CGE01 can be supplied with an integrated antenna (CGE01R).

The CGE01 harmonic steps can be switched between 80 MHz and 100 MHz as standard, allowing more frequency points to be measured than is possible with a fixed-frequency source. A 50 MHz/80 MHz step option is available by special request, allowing measurements compliant with chamber validations above 1 GHz according to CISPR 16.



CGE01C with MCN02 and BP01 battery pack

Features

- **Stable output**
 - Repeatable measurements
- **Conducted and radiated options**
 - Evaluation of both conducted and radiated systems
- **50 MHz to 18 GHz output**
 - Applications across a broad frequency spectrum
- **50 MHz step size**
 - Complies with CISPR 16 validation methods
- **Compact and portable**
 - Comparisons between sites and environments
 - Shielding effectiveness measurements even of small enclosures
- **Battery powered**
 - No power or interconnecting cables affecting measurements

Applications

- CISPR 16 verifications
- Shielding effectiveness of small enclosures e.g. PCs, servers, wireless communications equipment
- Radiated measurement systems validation and verification
- Reference source for:
 - Daily pre-test verification checks if required by the accreditation authorities
 - Long term performance monitoring
 - Spectrum analyser / receiver pre-checks
- Investigation of reverberation (mode stirred) chamber behaviour
- Characterisation of filter performance
- Cable loss measurements
- Inter-laboratory test programs
- Proficiency test programs

Manufacturer's calibrations

- CAL13** **Conducted** output power, 0 GHz to 18 GHz, measured using a spectrum analyser (CGE01C only)
- CAL09** **Radiated** field strength, 1 GHz to 18 GHz, measured at 3 m in a FAR using a spectrum analyser (CGE01R or CGE01C with monocone antenna only)

Specifications

| | |
|------------------------------|--|
| Frequency range | 50 MHz to 18 GHz direct connection into a 50 Ω system 1 GHz to 18 GHz radiated using the integral antenna (CGE01R) or additional monocone antenna (CGE01C) |
| Step Size | 80 MHz or 100 MHz switchable (50 MHz or 80 MHz switchable version available to special order) |
| Output connector | 50 Ω SMA socket (CGE01C only) |
| Temperature stability | 1 GHz to 16 GHz: <0.5 dB or 100 MHz to 18 GHz: <2 dB, at an ambient temperature of 15 °C to 35 °C |
| Time stability | Typically <1 dB over a 12 month period |
| Dimensions | CGE01C with battery pack – 76 mm diameter × 64 mm (74 mm incl. connector) CGE01C without battery pack – 76 mm diameter × 18 mm (28 mm incl. connector) CGE01R with battery pack – 76 mm diameter × 92 mm CGE01R without battery pack – 76 mm diameter × 46 mm |
| Weight | Approx 550 g (including battery) |
| Power supply | 5 V 2 Ahr battery pack External input 4.75 V to 7.5 V, 300 mA |
| Operating time | 6.5 hours typical with a fully charged battery pack |
| Indicators | Mode 1; 80 MHz steps. Mode 2; 50 MHz or 100 MHz steps |

Accessories

- MCN02** Detachable monocone antenna (1 GHz to 18 GHz optimum when used with CGE01C)
- BP01** 5 V 2 Ahr detachable battery pack

Standard kits: 80 MHz & 100 MHz switchable comb step size

| Part Number | Description | Parts included |
|-------------|---|--|
| CGE01KIT01 | Standard CGE01C comb generator emitter (conducted output) kit | <ul style="list-style-type: none"> CGE01C comb generator emitter with SMA output connector CAL13 – conducted output power measurement, 0 GHz to 18 GHz |
| CGE01KIT02 | Standard CGE01R comb generator emitter (radiated output) kit | <ul style="list-style-type: none"> CGE01R comb generator emitter with integral antenna CAL09 – radiated electric field strength measurement, at 3 m in a FAR, 1 GHz to 18 GHz |
| CGE01KIT03 | Enhanced CGE01C comb generator emitter (conducted and radiated output) kit | <ul style="list-style-type: none"> CGE01C comb generator emitter with SMA output connector MCN02 – detachable monocone antenna CAL13 – Standard conducted output power measurement, 0 GHz to 18 GHz |

Special order kits: 50 MHz & 80 MHz switchable comb step size

| Part Number | Description | Parts included |
|-------------|--|---|
| CGE01KIT04 | CGE01C comb generator emitter (conducted output) kit | <ul style="list-style-type: none"> CGE01C comb generator emitter with SMA output connector CAL13 – conducted output power measurement, 0 GHz to 18 GHz |
| CGE01KIT05 | CGE01R comb generator emitter (radiated output) kit | <ul style="list-style-type: none"> CGE01R comb generator emitter with integral antenna CAL09 – radiated electric field strength measurement, at 3 m in a FAR, 1 GHz to 18 GHz |
| CGE01KIT06 | Enhanced, CGE01C comb generator emitter (conducted and radiated output) kit | <ul style="list-style-type: none"> CGE01C comb generator emitter with SMA output connector MCN02 – detachable monocone antenna CAL13 – conducted output power measurement, 0 GHz to 18 GHz |

All kits are supplied with: BP01 5 V 2 Ahr rechargeable battery pack, BCH04 universal input battery charger, hard case, manual.

Comb Generator Emitter: CGE01 Typical output measurement results

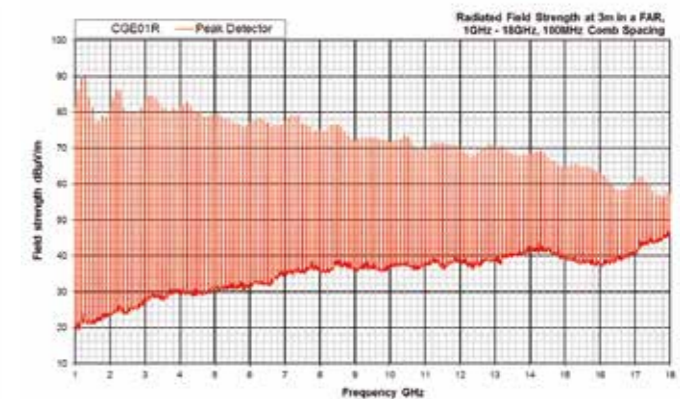
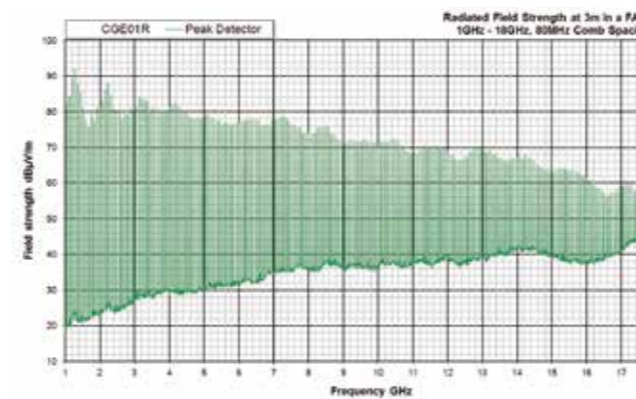
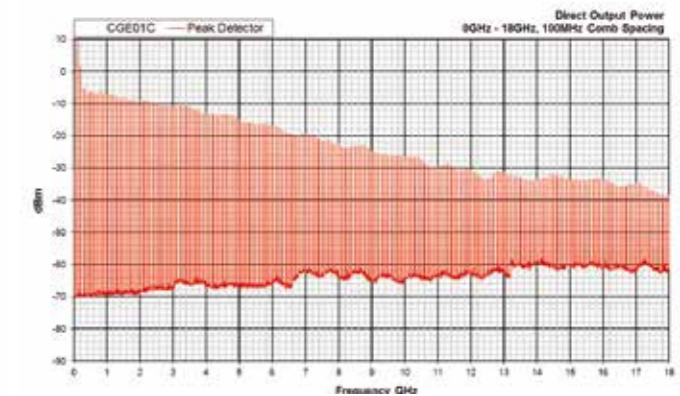
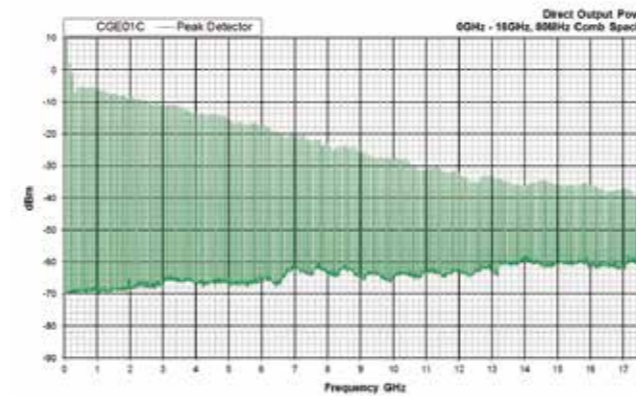

Comb Generator Emitter: CGE01 Radiation pattern

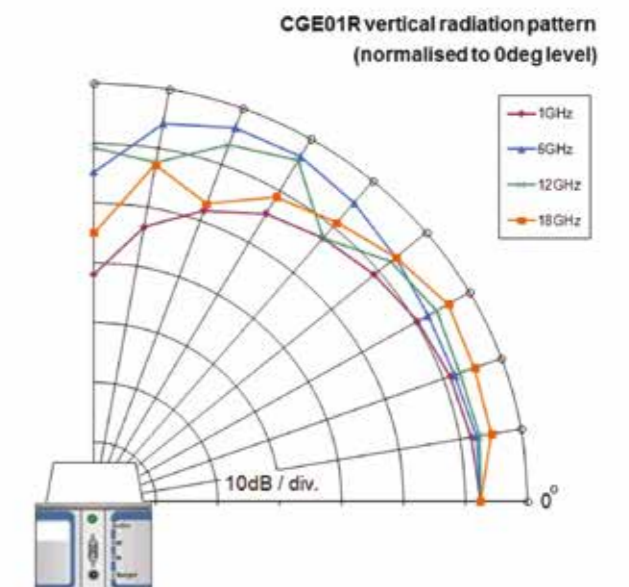
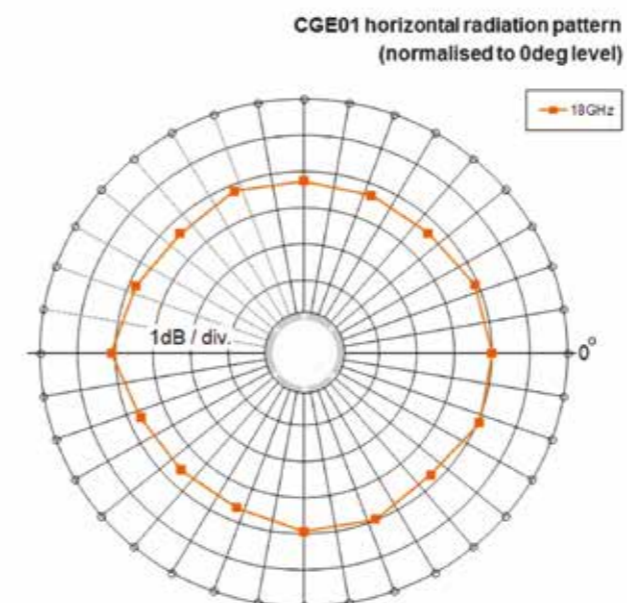

0° is in line with the indicator on the CGE

Product Technical Information

Comb Generator Emitter: CGE02

The Comb Generator Emitter 02 (CGE02) is a compact, battery powered, reference signal source that generates a broadband radiated and/or conducted output up to 26 GHz. When used as a verification reference source, the known output allows unknowns within systems or components to be measured or calculated. The compact size allows small enclosures to be evaluated when used as a reference source for shielding effectiveness measurements.

The CGE02 can be supplied with a 50 Ω SMA output connector (CGE02C) for direct connection to conducted test systems, or to an external antenna in order to generate test fields for evaluating radiated emission test systems. Alternatively, to achieve the best repeatability and compactness for purely radiated applications, the CGE02 can be supplied with an integrated antenna (CGE02R).

The CGE02 harmonic steps can be switched between 250 MHz and 256 MHz as standard, allowing more frequency points to be measured than is possible with a fixed-frequency source.



CGE02C with BP01 battery pack

Features

- **Stable output**
 - Repeatable measurements
- **Conducted and radiated options**
 - Evaluation of both conducted and radiated systems
- **250 MHz to 26 GHz output**
 - Applications across a broad frequency spectrum
 - Applicable to harmonics of high frequency systems
- **Compact and portable**
 - Comparisons between sites and environments
 - Shielding effectiveness measurements even of small enclosures
- **Battery powered**
 - No power or interconnecting cables affecting measurements

Applications

- **Shielding effectiveness of small enclosures** e.g. PCs, servers, wireless communications equipment
- **Radiated measurement systems validation and verification**
- **Reference source for:**
 - Daily pre-test verification checks if required by the accreditation authorities
 - Long term performance monitoring
 - Spectrum analyser / receiver pre-checks
- **Investigation of reverberation (mode stirred) chamber behaviour**
- **Characterisation of filter performance**
- **Cable loss measurements**
- **Inter-laboratory test programs**
- **Proficiency test programs**

Manufacturer's calibrations

- CAL14** **Conducted** output power, 0 GHz to 26 GHz, measured using a spectrum analyser (CGE02C only)
- CAL10** **Radiated** field strength, 1 GHz to 26 GHz, measured at 3 m in a FAR using a spectrum analyser (CGE02R or CGE02C with monocone antenna only)

Specifications

| | |
|------------------------------|--|
| Frequency range | 250 MHz to 26 GHz direct connection into a 50 Ω system 1 GHz to 26 GHz radiated using the integral antenna (CGE02R) or additional monocone antenna (CGE02C) |
| Step size | 250 MHz or 256 MHz switchable |
| Output connector | 50 Ω SMA socket (CGE02C only) |
| Temperature stability | <1 dB, at an ambient temperature of 15 °C to 35 °C |
| Time stability | Typically <1 dB over a 12 month period |
| Dimensions | CGE02C with battery pack – 76 mm diameter × 64 mm (74 mm incl. connector) CGE02C without battery pack – 76 mm diameter × 18 mm (28 mm incl. connector) CGE02R with battery pack – 76 mm diameter × 92 mm CGE02R without battery pack – 76 mm diameter × 46 mm |
| Weight | Approx 550 g (including battery) |
| Power supply | 5 V 2 AHr battery pack External input 5.00 V ± 0.25 V, 300 mA |
| Operating time | 6.5 hours typical with a fully charged battery pack |
| Indicators | Mode 1; 256 MHz steps. Mode 2; 250 MHz steps, incorrect power supply voltage |

Standard kits: 250 MHz & 256 MHz switchable comb step size

| Part Number | Description | Parts included |
|-------------------|--|---|
| CGE02KIT01 | Standard CGE02C comb generator emitter (conducted output) kit | <ul style="list-style-type: none"> • CGE02C comb generator emitter with SMA output connector • CAL14 – conducted output power measurement, 0 GHz to 26 GHz |
| CGE02KIT02 | Standard CGE02R comb generator emitter (radiated output) kit | <ul style="list-style-type: none"> • CGE02R comb generator emitter with integral antenna • CAL10 – radiated electric field strength measurement, at 3 m in a FAR, 1 GHz to 26 GHz |
| CGE02KIT03 | Enhanced CGE02C comb generator emitter (conducted and radiated output) kit | <ul style="list-style-type: none"> • CGE02C comb generator emitter with SMA output connector • MCN02 – detachable monocone antenna • CAL14 – conducted output power measurement, 0 GHz to 26 GHz |

All kits are supplied with: BP01 5 V 2 AHr rechargeable battery pack, BCH04 universal input battery charger, hard case, manual.

Accessories

- MCN02** Detachable monocone antenna (1 GHz to 26 GHz optimum used with CGE02C)
- BP01** 5 V 2 AHr detachable battery pack

Comb Generator Emitter: CGE02 Typical output measurement results

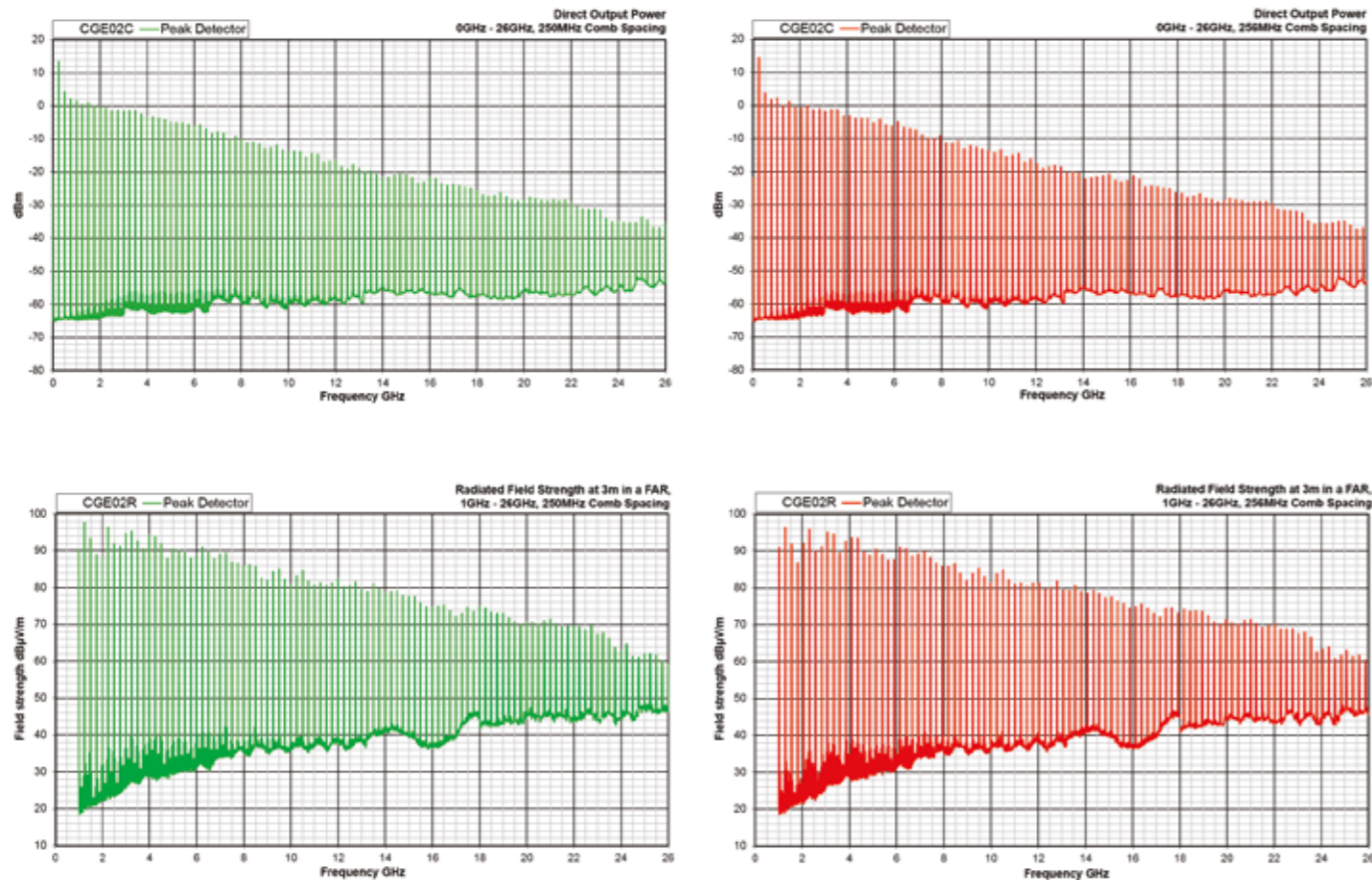

Comb Generator Emitter: CGE02 Radiation pattern

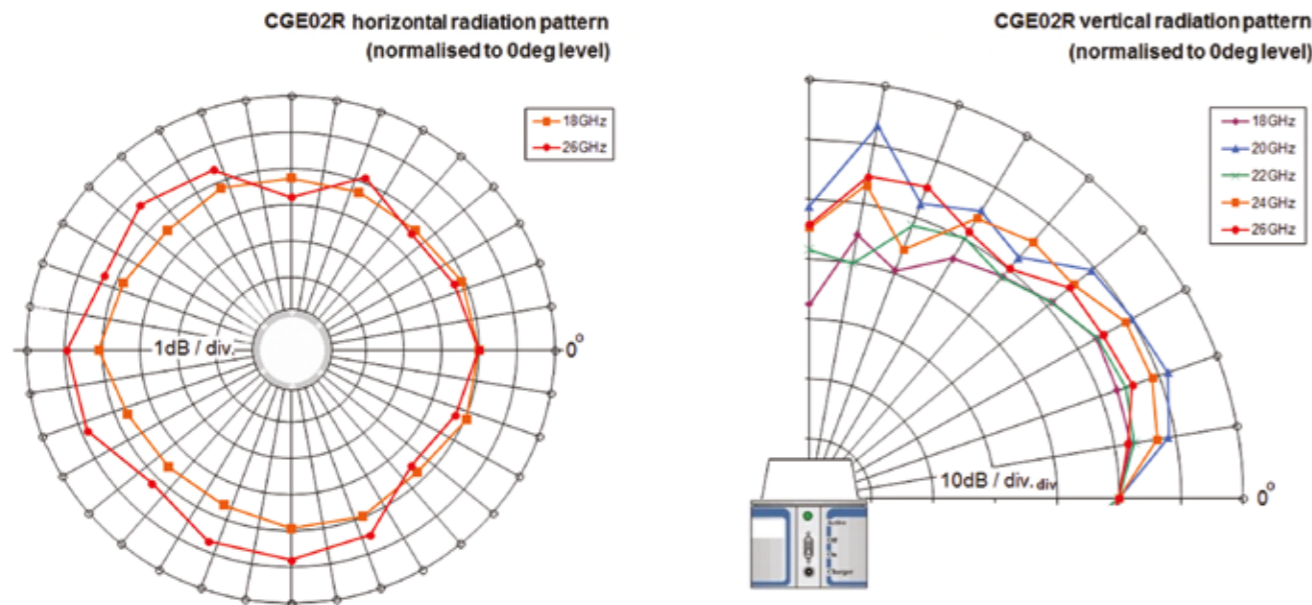

0° is in line with the indicator on the CGE

Product Technical Information Comb Generator Emitter: CGE03



CGE03 with BP01 battery pack

The Comb Generator Emitter 03 (CGE03) is a compact, battery powered, reference signal source that generates a broadband conducted output up to 40 GHz. When used as a verification reference source, the known output allows unknowns within systems or components to be measured or calculated.

The CGE03 is supplied with a 50 Ω 2.9 mm output connector for direct connection to conducted test systems, or to an external antenna in order to generate test fields for evaluating radiated emission test systems.

The CGE03 harmonic steps can be switched between 900 MHz and 1 GHz as standard, allowing more frequency points to be measured than is possible with a fixed frequency source.

Features

- **Stable output**
 - Repeatable measurements
- **900 MHz to 40 GHz output**
 - Applications across a broad frequency spectrum
 - Applicable to harmonics of high frequency systems
- **Compact and portable**
 - Comparisons between sites and environments
- **Battery powered**
 - No power or interconnecting cables affecting measurements

Applications

- **Reference source for:**
 - Daily pre-test verification checks if required by the accreditation authorities
 - Long term performance monitoring
 - Spectrum analyser / receiver pre-checks
- **Characterisation of filter performance**
- **Cable loss measurements**
- **Measuring amplifier gain and bandwidth**
- **Radiated measurement system validation and verification (requires an additional antenna)**
- **Inter-laboratory test programs**
- **Proficiency test programs**

Specifications

| | |
|------------------------------|--|
| Frequency range | 900 MHz to 40 GHz direct connection into a 50 Ω system 1 GHz to 26 GHz radiated using the optional MCN02 antenna |
| Step size | 900 MHz or 1 GHz switchable |
| Output connector | 50 Ω 2.9 mm socket |
| Temperature stability | <2 dB, at an ambient temperature of 15 °C to 35 °C |
| Time stability | Typically <1 dB over a 12 month period |
| Dimensions | CGE03C with battery pack – 76 mm diameter × 96 mm (102 mm incl. connector) CGE03C without battery pack – 76 mm diameter × 50 mm (56 mm incl. connector) |
| Weight | Approx 750 g (including battery) |
| Power supply | 5 V 2 AHr battery pack External input 5.00 V ± 0.25 V, 500 mA |
| Operating time | 4 hours typical with a fully charged battery pack |
| Indicators | Mode 1; 900 MHz steps. Mode 2; 1 GHz steps, incorrect power supply voltage |

Manufacturer's calibrations

- CAL15** Conducted output power, 0 GHz to 40 GHz, measured using a spectrum analyser
- CAL10** Radiated field strength, 1 GHz to 26 GHz, measured at 3 m in a FAR using a spectrum analyser (CGE03C with monocone antenna only)

Standard kits: 900 MHz & 1 GHz switchable comb step size

| Part Number | Description | Parts included |
|-------------------|--|---|
| CGE03KIT01 | Standard CGE03C comb generator emitter (conducted output) kit | <ul style="list-style-type: none"> CGE03C comb generator emitter with 2.9 mm socket output connector CAL15 – Standard conducted output power measurement, 0 GHz to 40 GHz |
| CGE03KIT02 | Standard CGE03C comb generator emitter (conducted and radiated output) kit | <ul style="list-style-type: none"> CGE03C comb generator emitter with 2.9 mm socket output connector MCN02 – detachable monocone antenna CAL15 – conducted output power measurement, 0 GHz to 40 GHz |

All kits are supplied with: BP01 5 V 2 AHr rechargeable battery pack, BCH04 universal input battery charger, hard case, manual.

Accessories

- MCN02** Detachable monocone antenna (1 GHz to 26 GHz optimum when used with CGE03)
- BP01** 5 V 2 AHr detachable battery pack

Comb Generator Emitter: CGE03

Typical output measurement results

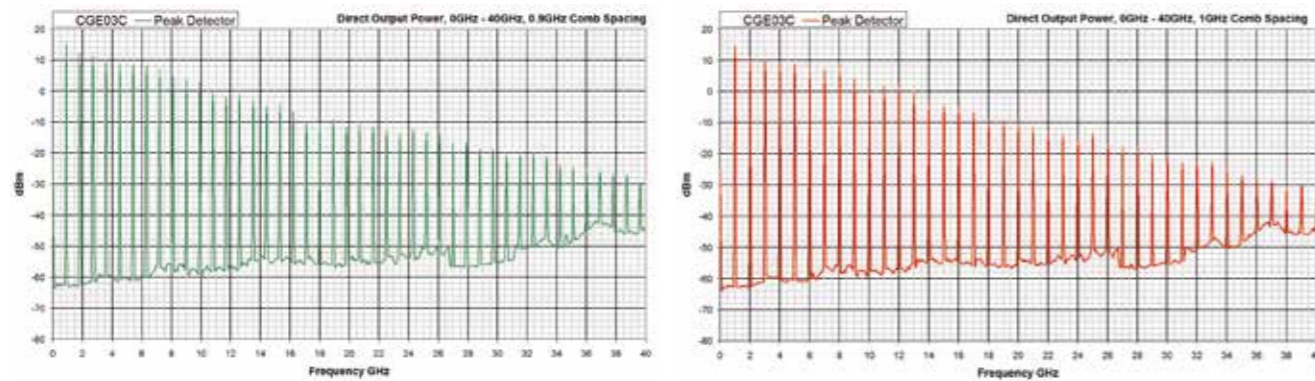

Product Technical Information

York Reference Source: YRS01

The YRS01 is a broadband **noise and comb** source that is capable of producing a continuous noise output from **9 kHz to 1 GHz**, or a comb of frequencies within the **5 kHz to 1 GHz** range, with step size being selected by the user. The noise generator enables observation of details over the full spectral range, while the comb generator allows for the reference signal output and noise floor to be viewed simultaneously, and also the frequency accuracy of measurement equipment to be checked.

The YRS01 is compact and battery powered, allowing operation as an electrically small source, which minimises the effect of the YRS01 itself when characterising the electromagnetic environment. The YRS01 is housed in a metal enclosure so that it can be mounted in direct contact with a metal ground plane as may be required by some tests. The YRS01 is compatible with the CGE battery pack BP01.

The YRS01 is supplied with a 50 Ω N-type output connector for direct connection to conducted measurement systems. An IEC 320 adapter is also available to provide a connection to LISN equipment, as well as an RJ11/RJ14/RJ25/RJ45 adapter for connection to telecoms ISNs, to provide a reference source for conducted emissions setups.



YRS01 with BP01 battery pack

For the radiated operation, antennas can be attached to the unit's output connector. Two monopole antennas, optimised for different frequency bands, are available. The YRS01 is an ideal source for carrying out checks on open area test sites (OATS) and anechoic chambers.

Features

- **Selectable noise or comb output**
 - Flexibility across a range of applications
- **Stable output**
 - Repeatable measurements
- **5 kHz to 1 GHz output**
 - Applications across a broad frequency spectrum
- **Conducted and radiated options**
 - Evaluation of both conducted and radiated systems
- **Compact and portable**
 - Comparisons between sites and environments
- **Battery powered**
 - No power or interconnecting cables affecting measurements

Applications

- **Investigation, characterisation and comparison of different measurement environments such as OATS, FAR or SAC.**
- **Validation and verification of radiated and conducted measurement systems, such as:**
 - Open Area Test Sites (OATS)
 - Fully Anechoic Rooms (FAR)
 - Semi-Anechoic Chambers (SAC)
 - Gigahertz Transverse ElectroMagnetic (GTEM) cells
- **Reference source for:**
 - Daily pre-test verification checks as required by Quality Management Systems e.g. ISO 17025, DEF STAN 59-411
 - Long term performance monitoring
 - Cable position investigation
 - Investigation and characterisation of screened room/anechoic room/OATS behaviour
 - Characterisation of filter performance
 - Cable loss measurements
- **Measuring amplifier gain and bandwidth**
- **Spectrum analyser/receiver pre-check**
- **Inter-laboratory test programs**
- **Proficiency test programs**

Manufacturer's calibrations

| | |
|--------------|--|
| CAL16 | Conducted output power, 9 kHz to 1 GHz, measured using a spectrum analyser. All modes. |
| CAL17 | Radiated field strength, 30 MHz to 1 GHz, measured on an OATS at 3 m or 10 m using a receiver. Noise, 1 MHz and 5 MHz modes, horizontal and vertical polarisation. |
| CAL18 | Radiated field strength, 30 MHz to 1 GHz, measured in a FAR at 3 m using a receiver. Noise, 1 MHz and 5 MHz modes, horizontal and vertical polarisation. |

Specifications: Noise mode

| | |
|------------------------------|---|
| Frequency range | 9 kHz to 1 GHz direct connection into 50 Ω system 30 MHz to 1 GHz radiated using TLM02 and MON03 monopole antennas |
| Temperature stability | < +/- 1 dB 9 kHz to 1 GHz, at an ambient temperature of 15 °C to 30 °C < +/- 2.5 dB 9 kHz to 1 GHz, at an ambient temperature of 5 °C to 40 °C |
| Time stability | < 1 dB (typical over a 12 month period) |
| Operating time | 7.5 hours (typical with fully charged battery pack) |

Specifications: Comb modes

| | |
|------------------------------|---|
| Frequency range | 5 kHz to 1 GHz direct connection into 50 Ω system 30 MHz to 1 GHz radiated using TLM02 and MON03 monopole antennas |
| Comb signal step size | Selectable between: 10 kHz (5 kHz, 15 kHz, 25 kHz to 3.005 MHz min.) 100 kHz (50 kHz, 150 kHz, 250 kHz to 30.05 MHz min.) 1 MHz (0.5 MHz, 1.5 MHz, 2.5 MHz to 300.5 MHz min.) 5 MHz (2.5 MHz, 7.5 MHz, 12.5 MHz to 1.0025 GHz min.) |
| Temperature stability | Amplitude: < +/- 0.5 dB 5 kHz to 1 GHz, at an ambient temperature of 15 °C to 30 °C < +/- 1 dB 5 kHz to 1 GHz, at an ambient temperature of 5 °C to 40 °C Frequency: < +/- 0.5 ppm, at an ambient temperature of 5 °C to 40 °C |
| Time stability | < 1 dB (typical over 12 month period) < +/- 1 ppm (typical over a 12 month period) |
| Operating time | 8.5 hours (typical with fully charged battery pack) |

Other

| | |
|-------------------------|--|
| Output connector | 50 Ω N-type socket |
| Dimensions | 76 mm diameter x 35 mm (56 mm including connector), without battery pack 76 mm diameter x 81 mm (102 mm including connector), with battery pack |
| Weight | 0.6 kg (including battery) |
| Power supply | 5 V 2 Ahr battery pack (order code BP01) External input 5.00 V \pm 0.25 V, 300 mA (mini-USB type B connector) |
| Indicators | Active, low battery |
| Controls | Rotary switch for mode selection |

Standard kits

| Part Number | Description | Parts included |
|-------------------|---|---|
| YRS01KIT01 | Standard YRS01 reference source kit with antenna | <ul style="list-style-type: none">• YRS01 reference source• BP01 – rechargeable battery pack• MON03 – 200 MHz to 1 GHz (optimum) 270 mm long monopole antenna |
| YRS01KIT02 | Enhanced YRS01 reference source kit with multiple antennas and LISN adaptor | <ul style="list-style-type: none">• YRS01 reference source• BP01 – rechargeable battery pack• TLM02 – 30 MHz to 300 MHz (optimum) 270 mm long top-loaded monopole antenna• MON03 – 200 MHz to 1 GHz (optimum) 270 mm long monopole antenna• LSA03 – LISN adapter with IEC 320 style connector |

All kits are supplied with: Hard case, BCH04 universal input battery charger, CAL16 – 9 kHz to 1 GHz output, power measurement using spectrum analyser, manual.

Accessories

| | |
|--------------|--|
| MON02 | Telescopic rod antenna |
| MON03 | 200 MHz to 1 GHz (optimum) 270 mm monopole antenna |
| TLM01 | 200 MHz to 1 GHz (optimum) 100 mm top-loaded monopole antenna |
| TLM02 | 30 MHz to 300 MHz (optimum) 270 mm top-loaded monopole antenna |
| LSA03 | LISN adapter with IEC 320 style connector |
| NIA01 | ISN adapter with RJ11/RJ14/RJ25/RJ45 style connection |

Note: The YRS01 can be supplied as an accessory with the CGE01, CGE02 and CGE03 kits. Details of kit options can be obtained on request from York EMC Services and authorised distributors.

York Reference Source: YRS01
Typical output measurement results

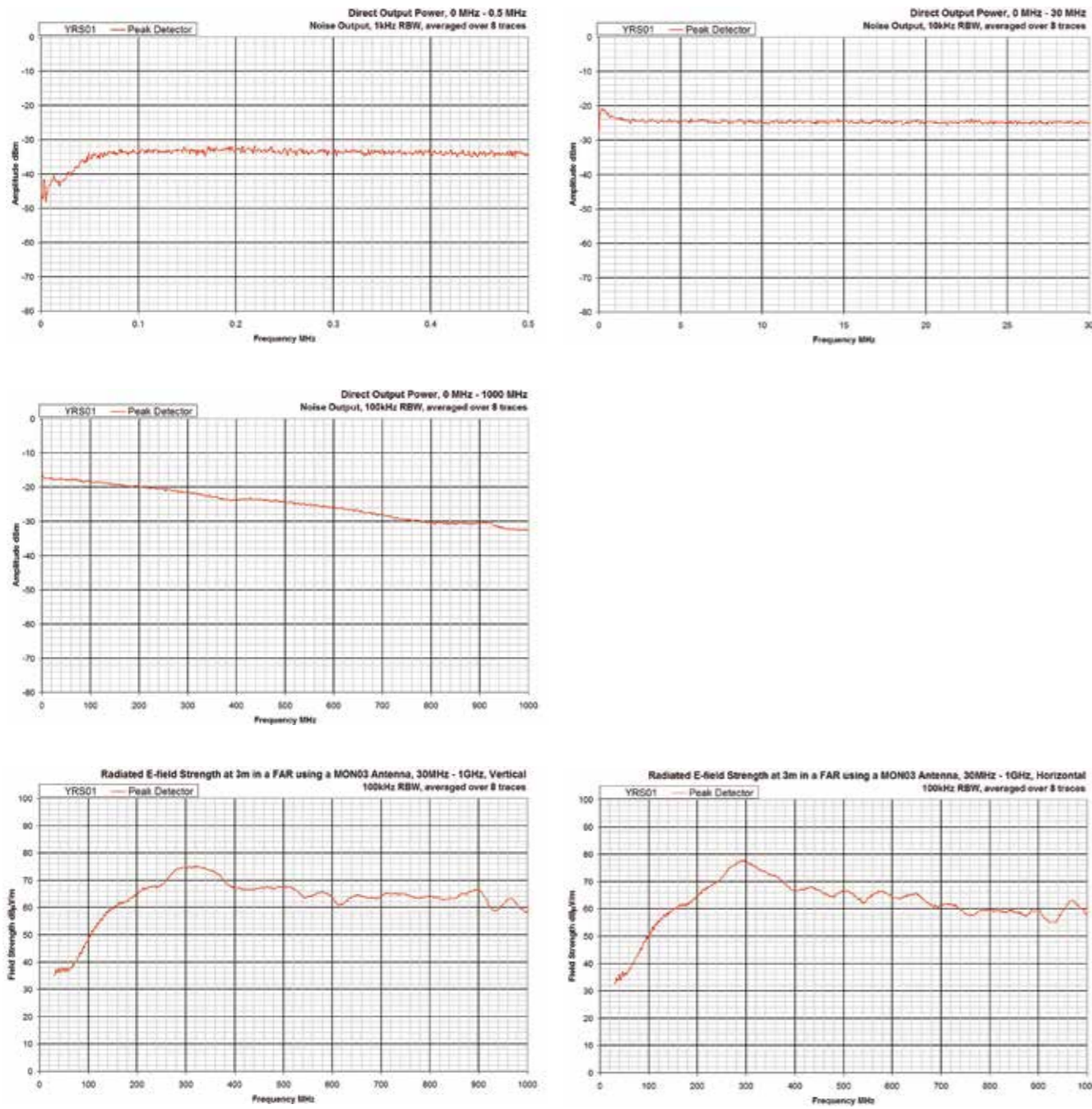

York Reference Source: YRS01
Typical output measurement results

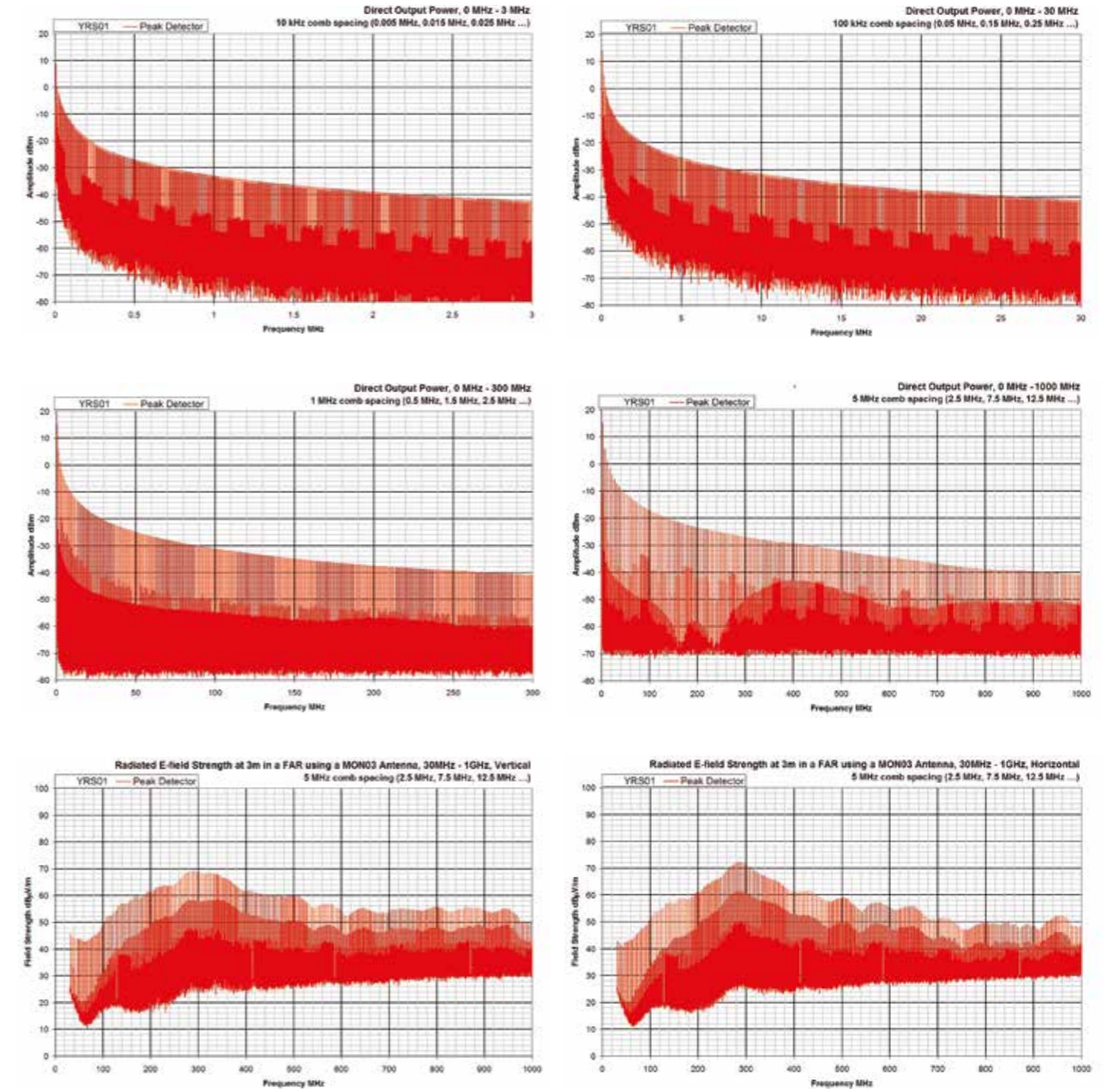

Note: Artefacts below the peak level are due to image scaling.

Product Technical Information

York Reference Source: YRS02

The YRS02 is a broadband noise and comb source that is capable of producing a continuous noise output from 9 kHz to 1 GHz, or a comb of frequencies within the 5 kHz to 1 GHz range, with step size being selected by the user. The noise generator enables observation of details over the full spectral range, while the comb generator allows for the reference signal output and noise floor to be viewed simultaneously, and the frequency accuracy of measurement equipment to be checked.

The YRS02 is compact and battery powered, allowing operation as an electrically small source, which minimises the effect of the YRS02 itself when characterising the electromagnetic environment. The YRS02 is housed in a metal enclosure so that it can be mounted in direct contact with a metal ground plane, as may be required by some tests.

The YRS02 is supplied with a 50 Ω N-type output connector for direct connection to conducted measurement systems. An IEC 320 adapter is also available to provide a connection to LISN equipment, as well as an RJ11/RJ14/RJ25/RJ45 adapter for connection to telecoms ISNs, to provide a reference source for conducted emissions setups.



YRS02 with MON03 antenna

For radiated operation, antennas can be attached to the unit's output connector. Two monopole antennas, optimised for different frequency bands, are available. The YRS02 is an ideal source for carrying out checks on open area test sites (OATS) and anechoic chambers.

Features

- **Selectable noise or comb output**
 - Flexibility across a range of applications
- **Stable output**
 - Repeatable measurements
- **5 kHz to 1 GHz output**
 - Applications across a broad frequency spectrum
- **Conducted and radiated options**
 - Evaluation of both conducted and radiated systems
- **Compact and portable**
 - Comparisons between sites and environments
- **Battery powered**
 - No power or interconnecting cables affecting measurements

Applications

- **Investigation, characterisation and comparison of different measurement environments such as OATS, FAR or SAC.**
- **Validation and verification of radiated and conducted measurement systems, such as:**
 - Open Area Test Sites (OATS)
 - Fully Anechoic Rooms (FAR)
 - Semi-Anechoic Chambers (SAC)
 - Gigahertz Transverse ElectroMagnetic (GTEM) cells
- **Reference source for:**
 - Daily pre-test verification checks as required by Quality Management Systems e.g. ISO 17025, DEF STAN 59-411
 - Long term performance monitoring
 - Cable position investigation
 - Investigation and characterisation of screened room/anechoic room/OATS behaviour
 - Characterisation of filter performance
 - Cable loss measurements
- **Measuring amplifier gain and bandwidth**
- **Spectrum analyser/receiver pre-check**
- **Inter-laboratory test programs**
- **Proficiency test programs**

Manufacturer's calibrations

- CAL16** **Conducted** output power, 9 kHz to 1 GHz, measured using a spectrum analyser. **All modes.**
- CAL17** **Radiated** field strength, 30 MHz to 1 GHz, measured on an OATS at 3 m or 10 m using a receiver. **Noise, 1 MHz and 5 MHz modes, horizontal and vertical polarisation.**
- CAL18** **Radiated** field strength, 30 MHz to 1 GHz, measured in a FAR at 3 m using a receiver. **Noise, 1 MHz and 5 MHz modes, horizontal and vertical polarisation.**

Specifications: Noise mode

| | |
|------------------------------|---|
| Frequency range | 9 kHz to 1 GHz direct connection into 50 Ω system 30 MHz to 1 GHz radiated using TLM02 and MON03 monopole antennas |
| Temperature stability | < +/-1 dB 9 kHz to 1 GHz, at an ambient temperature of 15 °C to 30 °C < +/-2.5 dB 9 kHz to 1 GHz, at an ambient temperature of 5 °C to 40 °C |
| Time stability | <1 dB (typical over a 12 month period) |
| Operating time | 7.5 hours (typical with alkaline batteries) |

Specifications: Comb modes

| | |
|------------------------------|---|
| Frequency range | 5 kHz to 1 GHz direct connection into 50 Ω system 30 MHz to 1 GHz radiated using TLM02 and MON03 monopole antennas |
| Comb signal step size | Selectable between: 10 kHz (5 kHz, 15 kHz, 25 kHz to 3.005 MHz min.) 100 kHz (50 kHz, 150 kHz, 250 kHz to 30.05 MHz min.) 1 MHz (0.5 MHz, 1.5 MHz, 2.5 MHz to 300.5 MHz min.) 5 MHz (2.5 MHz, 7.5 MHz, 12.5 MHz to 1.0025 GHz min.) |
| Temperature stability | Amplitude: < +/-0.5 dB 5 kHz to 1 GHz, at an ambient temperature of 15 °C to 30 °C < +/-1 dB 5 kHz to 1 GHz, at an ambient temperature of 5 °C to 40 °C Frequency: < +/-0.5 ppm, at an ambient temperature of 5 °C to 40 °C |
| Time stability | <1 dB (typical over 12 month period) < +/-1 ppm (typical over a 12 month period) |
| Operating time | 8 hours (typical with alkaline batteries) |

Other

| | |
|-------------------------|---|
| Output connector | 50 Ω N-type socket |
| Dimensions | 120 mm x 120 mm x 60 mm (79 mm including connector) |
| Weight | 1 kg (including cells) |
| Power supply | 4 x 1.5 V cells (AA or equivalent). Alkaline or rechargeable NiMH |
| Indicators | Active, low battery |
| Controls | Rotary switch for mode selection including OFF |

Standard kits

| Part Number | Description | Parts included |
|----------------------------|---|---|
| YRS02KIT01 | Standard YRS02 reference source kit with antenna | <ul style="list-style-type: none"> • YRS02 reference source • MON03 – 200 MHz to 1 GHz (optimum) 270 mm long monopole antenna |
| YRS02KIT02 | Enhanced YRS02 reference source kit with multiple antennas and LISN adaptor | <ul style="list-style-type: none"> • YRS02 reference source • TLM02 – 30 MHz to 300 MHz (optimum) 270 mm long top-loaded monopole antenna • MON03 – 200 MHz to 1 GHz (optimum) 270 mm long monopole antenna • LSA03 – LISN adapter with IEC 320 style connector |
| YRS Combination Kit | Enhanced YRS02 and YRS03 reference source kit with multiple antennas and LISN adaptor with output range from 5 kHz to 6 GHz | <ul style="list-style-type: none"> • YRS02 reference source • YRS03 reference source • TLM02 – 30 MHz to 300 MHz (optimum) 270 mm long top-loaded monopole antenna • MON03 – 200 MHz to 1 GHz (optimum) 270 mm long monopole antenna • MCN03 – 1 GHz to 6 GHz (optimum) monocone antenna • LSA03 – LISN adapter with IEC 320 style connector • CAL19 – 30 MHz to 6 GHz output power measured using a spectrum analyser, all modes (YRS03 only) |

All kits are supplied with: Hard case, 4 x AA alkaline cells, CAL16 – 9 kHz to 1 GHz output power measurement using spectrum analyser, all modes, manual.

Accessories

| | |
|--------------|--|
| MON02 | Telescopic rod antenna |
| MON03 | 200 MHz to 1 GHz (optimum) 270 mm monopole antenna |
| TLM01 | 200 MHz to 1 GHz (optimum) 100 mm top-loaded monopole antenna |
| TLM02 | 30 MHz to 300 MHz (optimum) 270 mm top-loaded monopole antenna |
| LSA03 | LISN adapter with IEC 320 style connector |
| NIA01 | ISN adapter with RJ11/RJ14/RJ25/RJ45 style connection |

York Reference Source: YRS02 Typical output measurement results

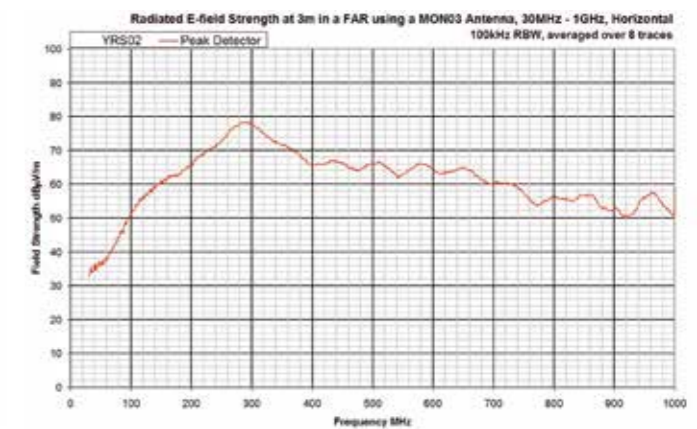
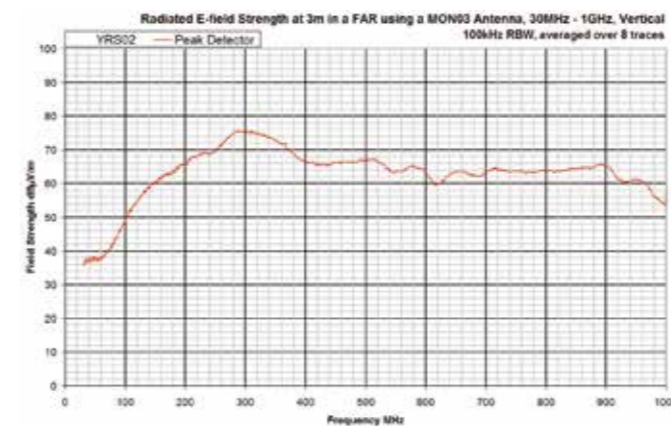
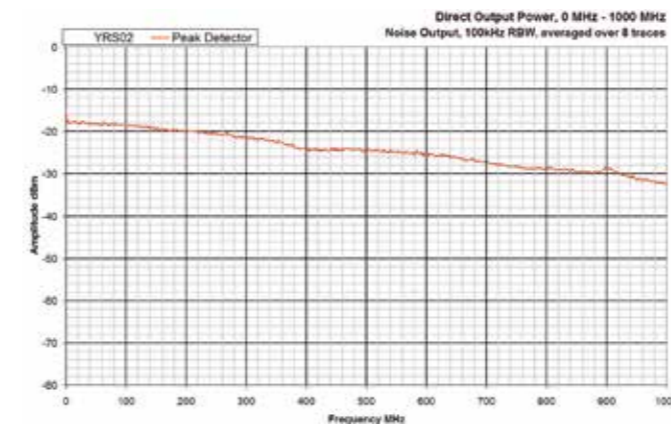
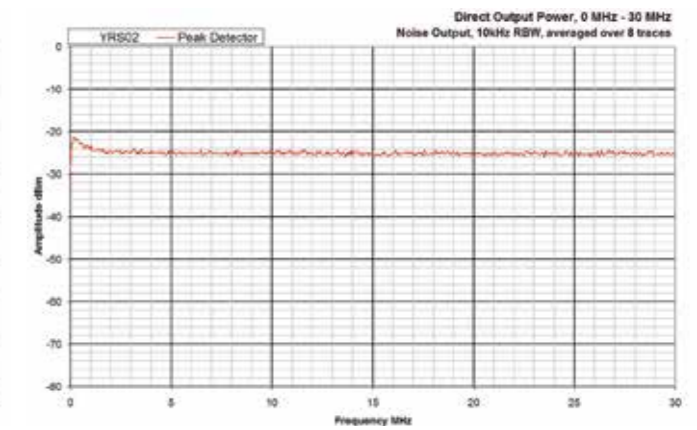
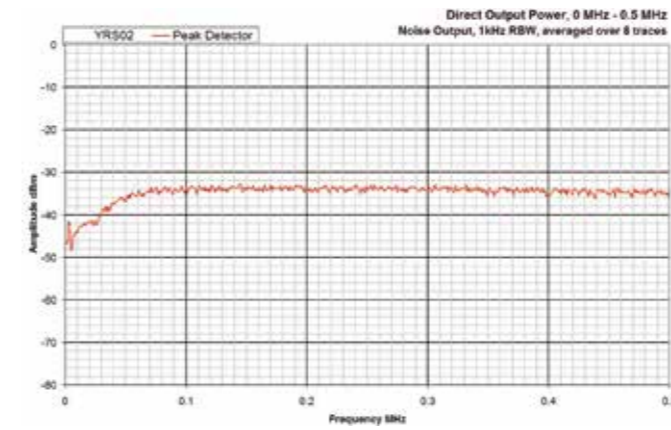

York Reference Source: YRS02 Typical output measurement results

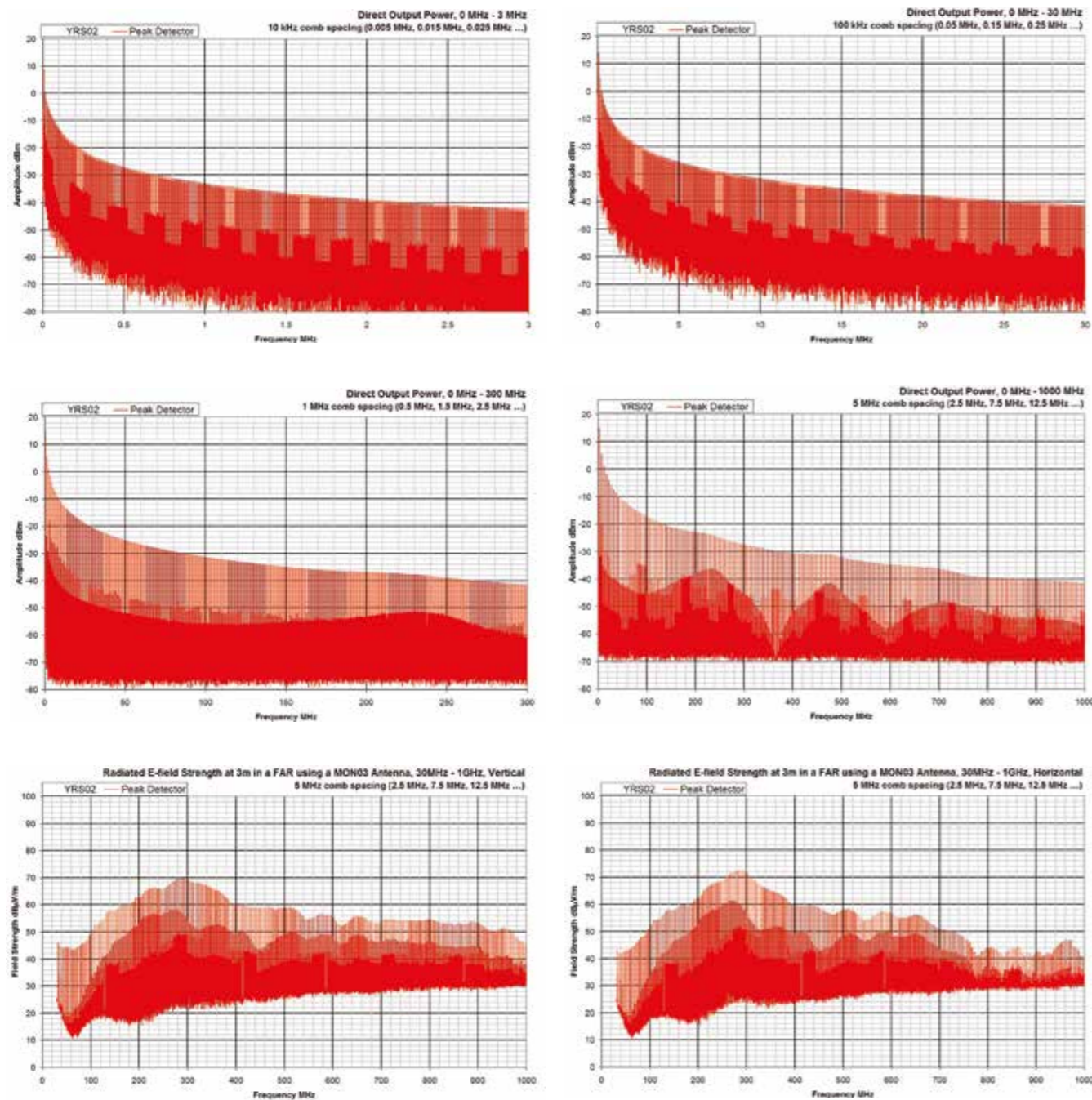

Note: Artefacts below the peak level are due to image scaling.

Product Technical Information York Reference Source: YRS03

The YRS03 is a multi-mode, broadband noise and comb source that is capable of producing a continuous noise output or a comb of frequencies within the 10 MHz to 6 GHz range, with the step size being selected by the user. The noise generator enables observation of details over the full spectral range, while the comb generator allows for the reference signal output and noise floor to be viewed simultaneously, and the frequency accuracy of measurement of equipment to be checked.

The YRS03 is a compact and battery powered, allowing operation as an electrically small source, which minimises the effect of the YRS03 itself when characterising the electromagnetic environment. The YRS03 is housed in a metal enclosure so that it can be mounted in direct contact with a metal ground plane as may be required by some tests.

The YRS03 is supplied with a 50 Ω N-type output connector for direct connection to conducted measurement systems. For radiated operation, antennas can be attached to the unit's output connector.



YRS03 with accessories

Three antennas, one monocone and two monopole optimised for different frequency bands, are available. The YRS03 is an ideal source for carrying out checks on Open Area Test Sites (OATS) and fully- or semi-anechoic chambers.

Features

- **Selectable noise or comb output**
 - Flexibility across a range of applications
- **Stable output**
 - Repeatable measurements
- **10 MHz to 6 GHz output**
 - Applications across a broad frequency spectrum
- **Conducted and radiated options**
 - Evaluation of both conducted and radiated systems
- **Compact and portable**
 - Comparisons between sites and environments
- **Battery powered**
 - No power or interconnecting cable effects on measurements

Applications

- **Investigation, characterisation and comparison of different measurement environments such as OATS, FAR or SAC.**
- **Validation and verification of radiated and conducted measurement systems, such as:**
 - Open Area Test Sites (OATS)
 - Fully Anechoic Rooms (FAR)
 - Semi-Anechoic Chambers (SAC)
 - Gigahertz Transverse ElectroMagnetic (GTEM) cells
- **Reference source for:**
 - Daily pre-test checks as required by the accreditation authorities e.g. ISO 17025, DEF STAN 59-411
 - Long term performance monitoring
 - Cable position investigation
 - Investigation of screened room behaviour
 - Characterisation of filter performance
 - Cable loss measurements
- **Measuring amplifier gain and bandwidth**
- **Spectrum analyser/receiver pre-check**
- **Inter-laboratory test programs**
- **Proficiency test programs**

Manufacturer's calibrations

| | |
|--------------|--|
| CAL17 | Radiated field strength, 30 MHz to 1 GHz, measured at 3 m OR 10 m on an OATS using a spectrum analyser or receiver. All modes. |
| CAL18 | Radiated field strength, 30 MHz to 1 GHz, measured at 3 m in a FAR using a spectrum analyser or receiver. All modes. |
| CAL19 | Conducted output power, 30 MHz to 6 GHz, measured using a spectrum analyser. All modes. |
| CAL21 | Radiated field strength, 1 GHz to 6 GHz, measured at 3 m in a FAR using a spectrum analyser or receiver. Noise, 20 MHz and 40 MHz comb modes. |

Specifications: Noise mode

| | |
|------------------------------|---|
| Frequency range | 10 MHz to 6 GHz direct connection into 50 Ω system 30 MHz to 6 GHz radiated using MON03 monopole and MCN03 monocone antennas |
| Temperature stability | < +/-1 dB, at an ambient temperature of 15 °C to 30 °C < +/-1.5 dB, at an ambient temperature of 5 °C to 40 °C |
| Time stability | <1 dB typical over a 12 month period |
| Operating time | 6.5 hours typical with alkaline cells |

Specifications: Comb modes

| | |
|------------------------------|---|
| Frequency range | 10 MHz to 6 GHz direct connection into 50 Ω system 30 MHz to 1 GHz radiated using TLM02 and MON03 monopole antennas |
| Comb signal step size | Selectable between: 5 MHz 5 MHz, 10 MHz, ... 3 GHz min. 10 MHz 10 MHz, 20 MHz, ... 3 GHz min. 20 MHz 20 MHz, 40 MHz, ... 6 GHz min. 40 MHz 40 MHz, 80 MHz, ... 6 GHz min. |
| Temperature stability | Amplitude: < +/-1 dB, at an ambient temperature of 15 °C to 30 °C < +/-1.5 dB, at an ambient temperature of 5 °C to 40 °C Frequency: < +/- 0.5 ppm from 5 °C to 40 °C |
| Time stability | <1 dB typical over 12 month period < +/-1 ppm typical over a 12 month period |
| Operating time | 14 hours typical with alkaline cells |

Other

| | |
|-------------------------|---|
| Output connector | 50 Ω N-type socket |
| Dimensions | 120 mm x 120 mm x 60 mm (79 mm including connector) |
| Weight | 1 kg (including cells) |
| Power supply | 4 x 1.5 V cells (AA or equivalent). Alkaline or rechargeable. |
| Indicators | Active, low battery |
| Controls | Rotary switch for mode selection including OFF |

Standard kits

| Part Number | Description | Parts included |
|----------------------------|---|--|
| YRS03KIT01 | Standard YRS03 reference source kit with antenna | <ul style="list-style-type: none"> • YRS03 reference source • MCN03 – 1 GHz to 6 GHz (optimum) monocone antenna |
| YRS03KIT02 | Enhanced YRS03 reference source kit with multiple antennas | <ul style="list-style-type: none"> • YRS03 reference source • MCN03 – 1 GHz to 6 GHz (optimum) monocone antenna • TLM02 – 30 MHz to 300 MHz (optimum) 270 mm long top-loaded monopole antenna • MON03 – 200 MHz to 1 GHz (optimum) 270 mm long monopole antenna |
| YRS Combination Kit | Enhanced YRS02 and YRS03 reference source kit with multiple antennas and LISN adaptor with output range from 5 kHz to 6 GHz | <ul style="list-style-type: none"> • YRS02 reference source • YRS03 reference source • TLM02 – 30 MHz to 300 MHz (optimum) 270 mm long top-loaded monopole antenna • MON03 – 200 MHz to 1 GHz (optimum) 270 mm long monopole antenna • MCN03 – 1 GHz to 6 GHz (optimum) monocone antenna • LSA03 – LISN adapter with IEC 320 style connector • CAL16 – 9 kHz to 1 GHz output power measured using a spectrum analyser, all modes (YRS02 only) |

All kits are supplied with: Alkaline batteries; hard case; manual; CAL19 – 30 MHz to 6 GHz output power measurements in all modes using a spectrum analyser or receiver.

Accessories

| | |
|--------------|---|
| TLM01 | 200 MHz to 1 GHz (optimum) 100 mm top-loaded monopole antenna |
| TLM02 | 30 MHz to 300 MHz (optimum) 270 mm long top-loaded monopole antenna |
| MON03 | 200 MHz to 1 GHz (optimum) 270 mm monopole antenna |
| MCN03 | 1 GHz to 6 GHz (optimum) 120 mm diameter monocone antenna |
| LSA03 | LISN adapter with IEC 320 style connector |
| NIA01 | ISN adapter with RJ11/RJ14/RJ25/RJ45 style connection |

York Reference Source: YRS03
Typical output measurement results

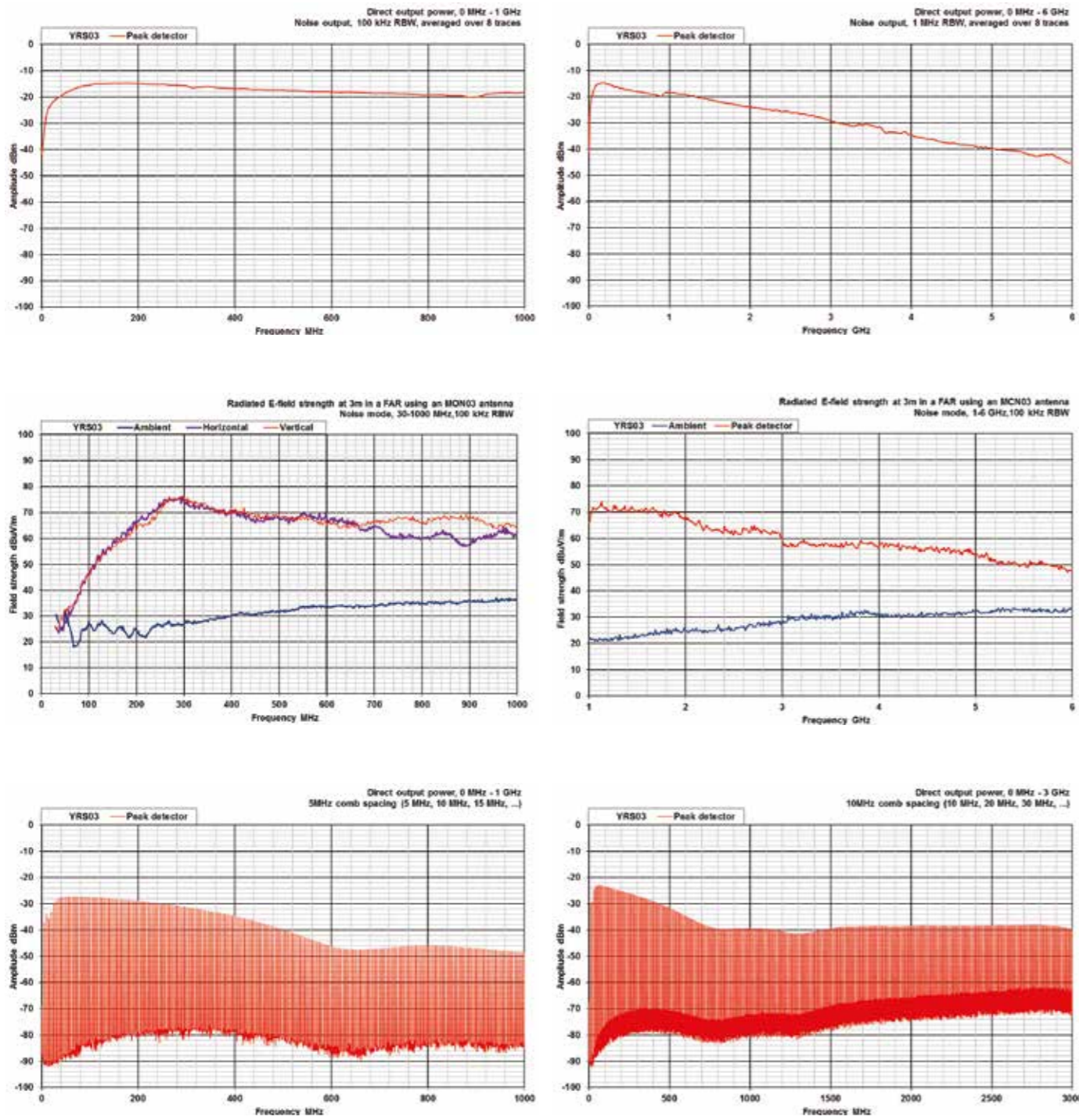

Note: Artefacts below the peak level are due to image scaling.

York Reference Source: YRS03
Typical output measurement results

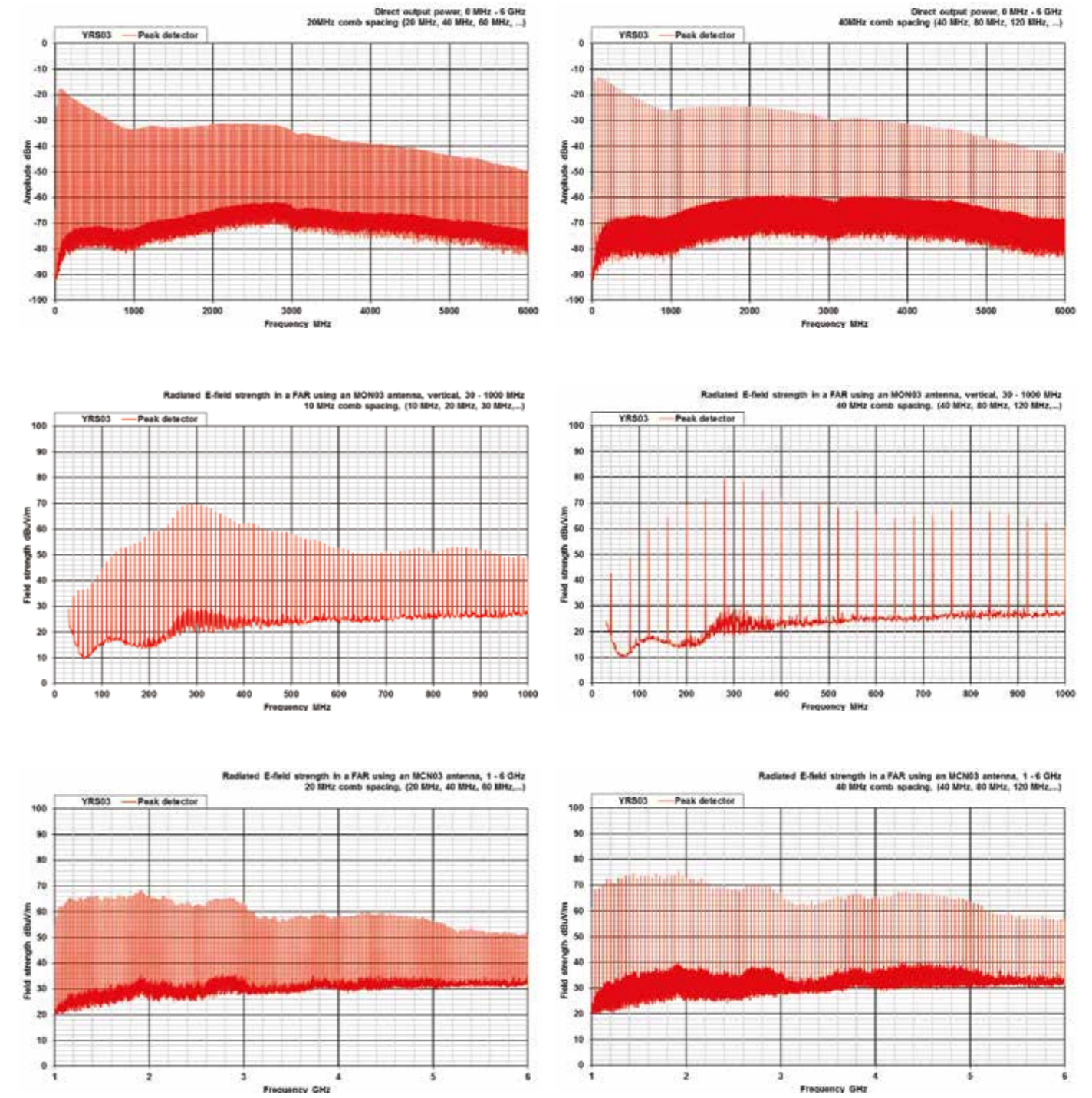

Note: Artefacts below the peak level are due to image scaling.

Product Technical Information

Active Receive Antenna: ARA 01

The Active Receive Antenna (ARA01) is a compact emissions antenna with an antenna factor comparable to a conventional wideband passive antenna such as the Bilog™.

The small size makes the ARA 01 particularly suitable for use in anechoic chambers; however it can also be used on an Open Area Test Site (OATS) or at on-site locations.

The ARA 01 features two sets of interchangeable Dipole Antenna Elements (DAE). The standard set (DAE01) is optimized for 200 MHz to 1 GHz, with usable sensitivity down to 30 MHz. For improved sensitivity between 30 MHz to 300 MHz, the optional DAE02 set is available.

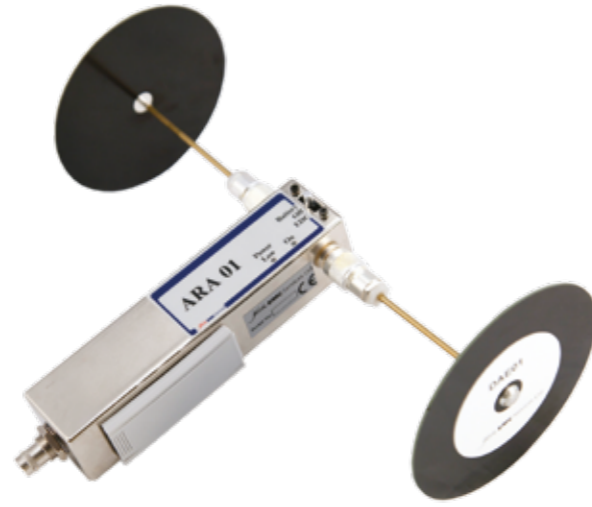

ARA01 with two DAE01 Antennas

Features

- **Stable**
 - Repeatable measurements
- **Bilog™ equivalent antenna factor**
 - See output measurement graphs
- **30 MHz to 1 GHz range**
 - Most commonly used EMC measurement range
- **Compact and portable**
 - Measurements in confined spaces
 - Measurements where equipment must be hand carried
 - Field testing
- **Low cost**
 - Affordable measurement systems

Applications

- Radiated emissions measurements in a confined area
- Low cost alternative to passive wideband antenna
- Portable measurement systems

Specifications

| | |
|------------------------------|---|
| Frequency range | 30 MHz to 1 GHz (200 MHz to 1 GHz optimum) using DAE01 antenna elements 30 MHz to 300 MHz (optimum) using DAE02 antenna elements |
| Output connector | 50 Ω BNC jack |
| Dynamic range | 90 dB |
| 1 dB compression | 15.4 dBm / 35.5 mW / 1.33 V (in a 50 Ω system) |
| Antenna factor | See graph below |
| Temperature stability | <1 dB, at an ambient temperature of 5 °C to 45 °C |
| Time stability | Typically <1 dB over a 12 month period |
| Dimensions | 34 mm × 34 mm × 150 mm (168 mm including connector) excluding dipole elements |
| Weight | 0.39 kg (including battery) |
| Power supply | Single 9 V battery (PP3 or equivalent) |
| Operating time | 6.5 hours typical with alkaline cells |
| Indicators | Power on, low battery |

Manufacturer's calibrations

CAL08 Antenna factor, 30 MHz to 1 GHz, derived from a calibrated standard.

Standard kits

| Part Number | Description | Parts included |
|-------------------|---|---|
| ARA01KIT01 | Standard ARA 01 active receive antenna kit with pair of 200 MHz to 1 GHz antennas | <ul style="list-style-type: none"> • ARA 01 Active receive antenna • 2×DAE01 – 100 mm long antenna elements • CAL08 – antenna factors, 30 MHz to 1 GHz • Alkaline battery • Case |

Accessories

| | |
|--------------|---|
| DAE01 | 200 MHz to 1 GHz (optimum) set of 100 mm long antenna elements |
| DAE02 | 30 MHz to 300 MHz (optimum) set of 270 mm long antenna elements |
| TRA01 | Tripod adaptor with ARA 01 mounting bracket |

Active Receive Antenna: ARA 01

Typical characteristics

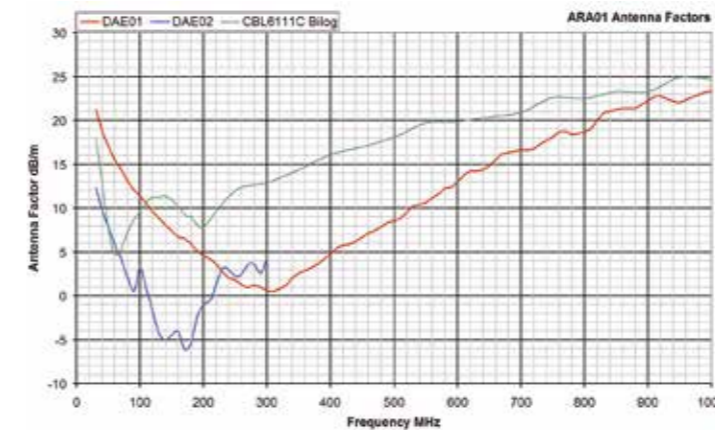

Active Receive Antenna Radiation Pattern, DAE01 fitted

Scale in dB

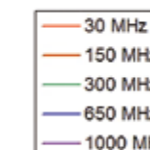
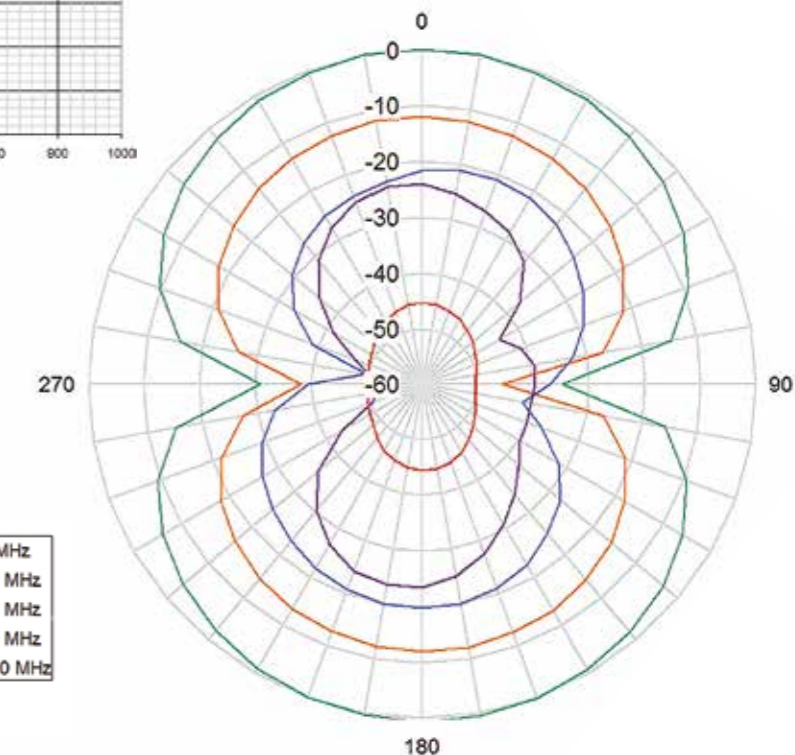

Product Technical Information

Harmonics and Flicker Generator: HFG01

The Harmonics & Flicker Generator (HFG01) has been designed for the purpose of verifying harmonic and flicker test equipment. It provides an easy and reliable way to externally check the performance of the measurement system to the EN/IEC 61000-3-2 harmonics and EN/IEC 61000-3-3 flicker standards; particularly important as these tests rely on software control and calculation, and for which there is no intuitive sense of the response.



HGF01

The HFG01 provides a series of harmonic and flicker disturbances of a nominal but stable level. This allows the user to periodically verify their test equipment, helping maintain compliance with standards and laboratory quality procedures. Alternatively, due to its stability, it may be used as a transfer standard from a known, calibrated test system.

The HFG01 is a standalone device and requires no additional equipment. It connects directly to the test equipment and simulates the equipment under test (EUT), generating known, repeatable levels of harmonic and flicker disturbance.

Features

- **Stable load simulation**
 - Repeatable measurements for test system verification
- **Injects harmonics to EN 61000-3-2 and flicker to EN 61000-3-3**
 - Evaluation of test systems specifically to EN standards
- **Harmonic test modes**
 - Steady-state harmonic-rich load current, representing a fixed load
 - Harmonic-rich load currents fluctuating between two load conditions
- **Flicker test modes**
 - Fixed level of mains disturbance at 1 Hz rate
 - Fixed level of mains disturbance at 8.33 Hz rate
- **Compact and portable**
 - Comparisons between sites and environments

Applications

- **Harmonics and flicker measurement systems validation and verification**
- **Reference source for:**
 - Daily pre-test verification checks if required by the accreditation authorities e.g. ISO 17025
 - Long term performance monitoring
- **Comparison of different harmonics and flicker measurement systems**

Manufacturer's calibrations

- CAL12** Measurement of harmonic and flicker disturbance generated:
- **Harmonics**
 - Measurement of load current made according to EN 61000-3-2 in Steady State and Fluctuating Harmonics modes. Fundamental (50 Hz) to 40th harmonic.
 - **Flicker**
 - Measurement of short term flicker (P_{st}) made according to EN 61000-3-3 with disturbance at 1 Hz and 8.33 Hz rates

Specifications: Noise mode

| | |
|-------------------------------|---|
| Disturbances generated | Up to 40 th harmonic: 50 Hz to 2 kHz |
| Output connector | Captive BS 1363 3-pin UK mains plug, for connection to test equipment |
| Dimensions | 330 mm × 320 mm × 170 mm |
| Weight | 6.5 kg |
| Power supply | 230 Vac, 50 Hz, 400 W (maximum) |
| Indicators | Thermal shutdown |
| Harmonic current | (see graphs) |
| Flicker disturbance | (see graphs) |

Standard kits

| Part Number | Description | Parts included |
|-------------------|--|--|
| HFG01KIT01 | Standard HFG01 harmonics and flicker generator kit | <ul style="list-style-type: none"> • HFG01 harmonic and flicker generator • CAL12 – measurement of harmonics and flicker generated, all modes • US and EU mains plug adapters • Manual |

Harmonics and Flicker Generator: HFG01 Typical output measurement results

Harmonic disturbance:

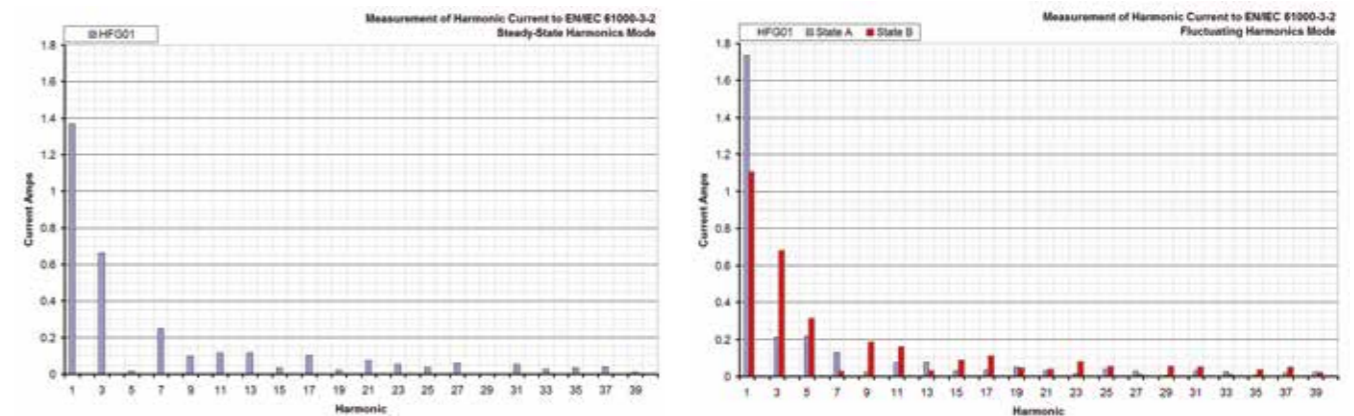

| Flicker disturbance: | Rate | P_{st}^* |
|----------------------|----------|------------|
| | 1.0 Hz | 0.450 |
| | 8.333 Hz | 1.10 |

*Note that the actual P_{st} measured may depend on the measurement equipment used.

Product Technical Information

Harmonics and Flicker Generator: HFG02

The Harmonics & Flicker Generator (HFG02) is a multifunction electronic load for the purpose of verifying harmonic and flicker test equipment. It provides an easy and reliable way to externally check the performance of the measurement system to the EN/IEC 61000-3-2 harmonics and interharmonics and EN/IEC 61000-3-3 flicker standards. A reference source is particularly useful where there is little intuitive sense of the expected response and the tests rely on software control and calculation to produce a result.

The HFG02 provides a range of harmonic and flicker disturbances of a nominal but stable level. This allows the user to periodically verify their test equipment, helping maintain compliance with standards and laboratory quality procedures. Alternatively, due to its stability, it may be used as a transfer standard from a known, calibrated test system.



The HFG02 is a standalone device that connects directly to the test equipment and simulates the equipment under test (EUT), generating known, repeatable levels of harmonic and flicker disturbance.

Features

- **Stable load simulation**
 - Repeatable measurements for test system verification
- **Injects harmonics and interharmonics to EN 61000-3-2 and flicker to EN 61000-3-3**
 - Evaluation of test systems specified to EN standards
- **Harmonic test modes**
 - Steady-state harmonic-rich load current, representing a fixed load
 - Harmonic-rich load currents fluctuating between two load conditions
 - Interharmonic load currents at 5 Hz and 10 Hz rates
 - Harmonic and interharmonic-rich load current
- **Flicker test modes**
 - Fixed level of mains disturbance at 1 Hz rate
 - Fixed level of mains disturbance at 8.33 Hz (50 Hz supply) or 8.6 Hz rates (60 Hz supply)
- **EUT modes**
 - Simulates waveforms generated by several different types of equipment:
 - Half-wave rectifier
 - Analogue dimmer
 - Intermittent flicker

- **Compact and portable**
- **Dual supply operation**
 - Automatically detects 115 Vac and 230 Vac systems and adjusts its output to match
 - Test supply voltage and frequency indication
- **Independent power supply**
 - Separate power supply to the HFG02, to avoid contamination of the test signals

Applications

- **Harmonics and flicker measurement systems validation and verification**
- **Reference source for:**
 - Daily pre-test verification checks, if required by accreditation authorities
 - Long term performance monitoring of the test system
- **Comparison of different harmonics and flicker measurement systems**

Manufacturer's calibrations

- CAL22** Measurement of harmonic and flicker disturbance generated:
- Harmonics
 - Measurement of load current according to EN 61000-3-2 in Fixed, Fluctuating and Interharmonic modes. Fundamental to 40th harmonic, 115 Vac/60 Hz and 230 Vac/50 Hz test supply
 - Flicker
 - Measurement of short term flicker (P_{st}) according to EN 61000-3-3 with disturbance at 1 Hz and 8.33 Hz/8.6 Hz rates. 115 Vac/60 Hz and 230 Vac/50 Hz test supply

Specifications

| | |
|-------------------------------|--|
| Test supply | Voltage: 115 Vac (nominal), 230 Vac (nominal) Frequency: 50 Hz, 60 Hz Power: 500 W (maximum) |
| Disturbances generated | Up to 40 th harmonic: 50 Hz to 2 kHz (50 Hz), 60 Hz to 2.4 kHz (60 Hz) |
| Dimensions | 330 mm × 320 mm × 170 mm (not including test supply connector) |
| Weight | 8 kg |
| Power supply | External power supply, 24 Vdc, 2 A maximum |
| Power supply connector | 2.1 mm DC power socket |
| Ext. PSU input rating | 100 – 240 Vac, 50-60 Hz, 50 W (maximum) |
| Test supply connector | 1.3 m captive lead with BS 1363 3-pin UK mains plug, for connection to test equipment. Adapters for EU and US style mains connectors included. |
| Indicators | Test supply voltage, test supply frequency, test enabled, alarm (thermal overload, system error) |
| Harmonic current | (see graphs) |
| Flicker disturbance | (see graphs) |

Standard kits

| Part Number | Description | Parts included |
|-------------------|--|--|
| HFG02KIT01 | Standard HFG02 harmonics and flicker generator kit | <ul style="list-style-type: none">• HFG02 harmonic and flicker generator• CAL22 – measurement of harmonics, interharmonics and flicker generated• US and EU mains plug adapters• External power supply• CDROM containing User Manual, Test Certificate and Tabulated Results |

Harmonics and Flicker Generator: HFG02

Typical output measurement results

Typical harmonic output levels

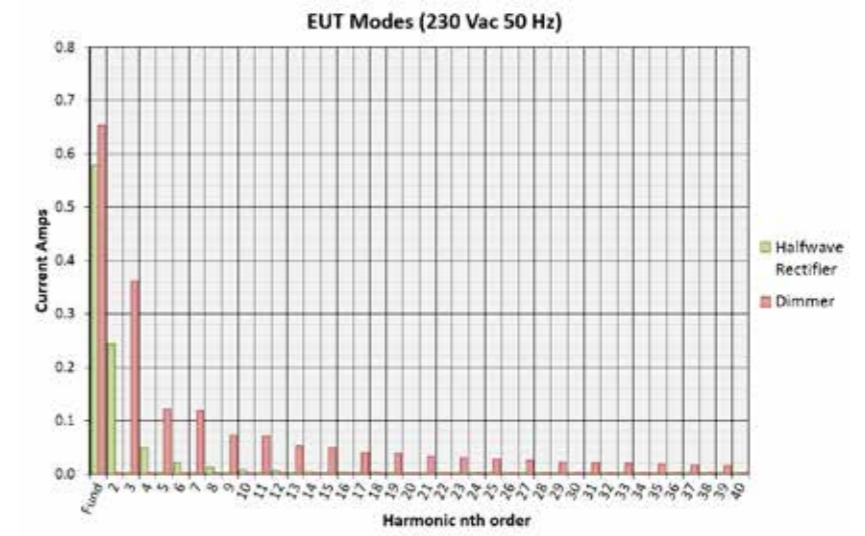
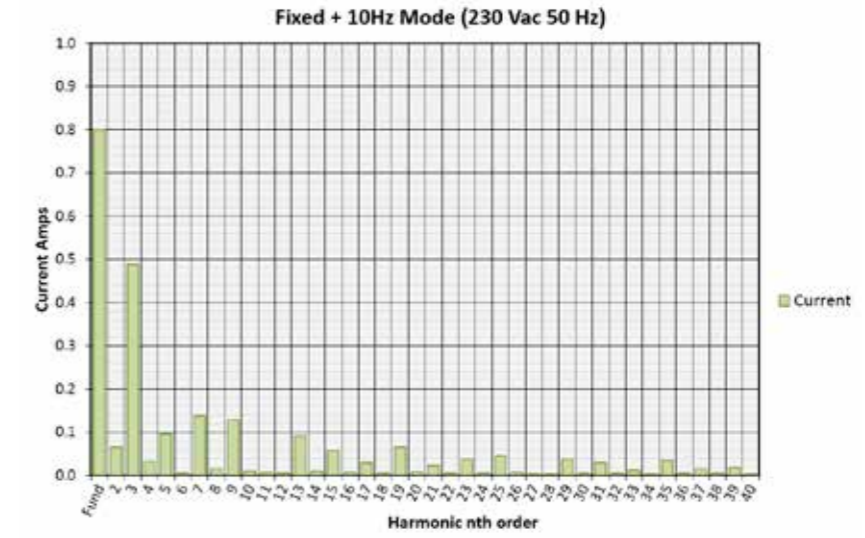
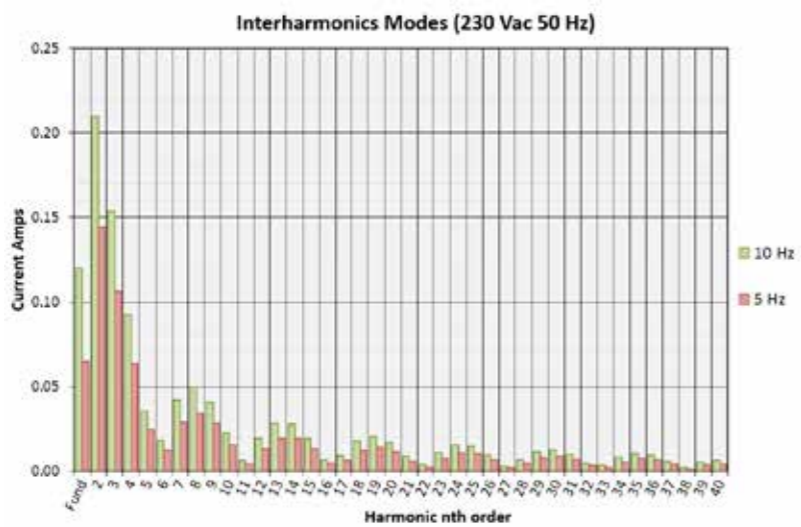
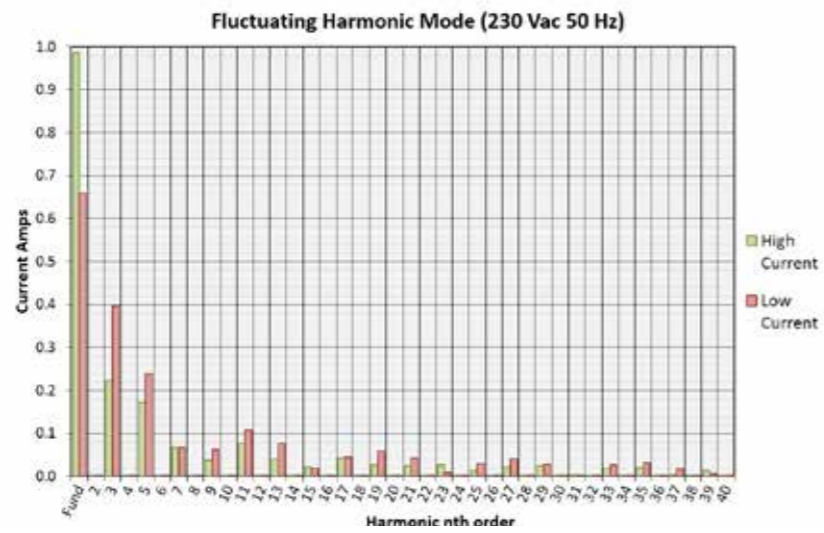
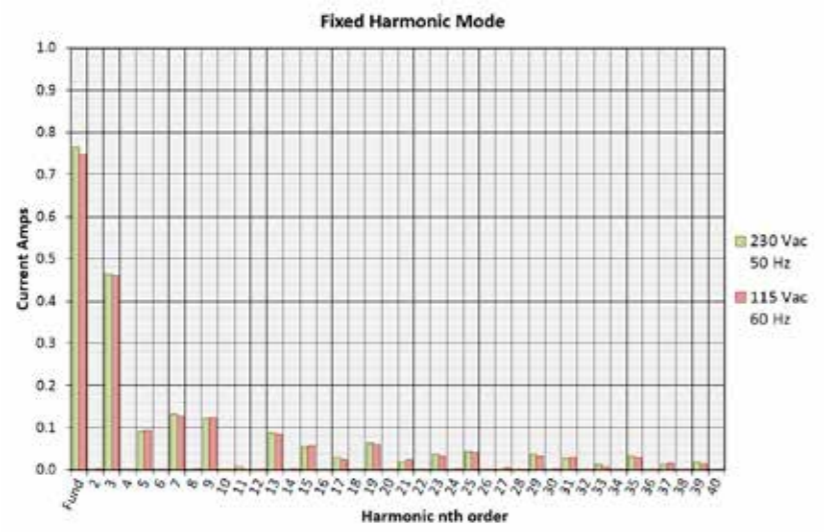

Typical flicker disturbance results

115 V, 60 Hz:

| Rate | P_{st} | d_{max} (absolute) % |
|--------|----------|------------------------|
| 1.0 Hz | 0.451 | 0.22 |
| 8.6 Hz | 1.061 | 0.21 |

230 V, 50 Hz:

| Rate | P_{st} | d_{max} (absolute) % |
|---------|----------|------------------------|
| 1.0 Hz | 0.451 | 0.19 |
| 8.33 Hz | 1.095 | 0.20 |

Example of a typical test setup

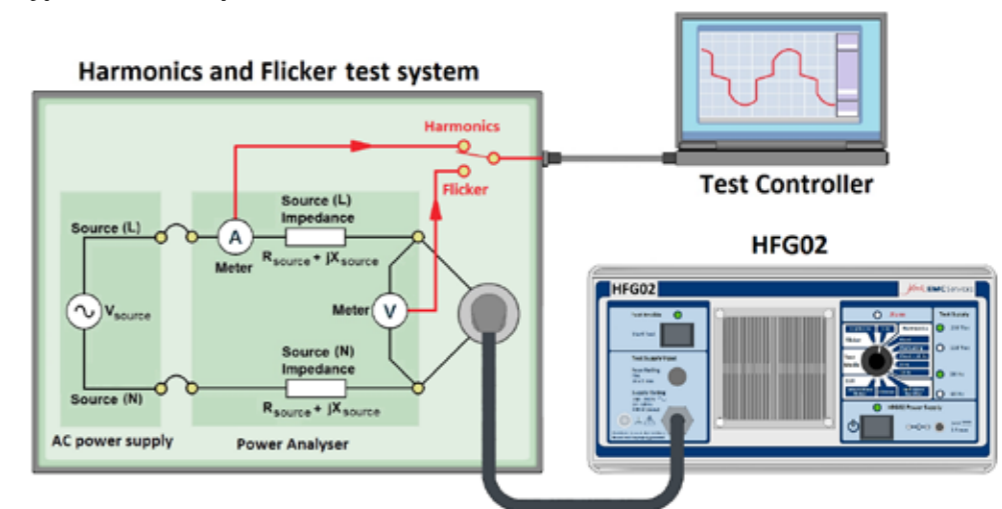

Product Technical Information

Cable Coupling Clamp: CCC01

The Cable Coupling Clamp (CCC01) is a reusable test jig for the purpose of measuring the shielding properties of cables. The CCC01 is designed to allow easy positioning of the test and injection feed cables in accordance with the layout described in IEC 96-1 Amendment 2 1993-06. This simplifies the process of making repeatable measurements aimed at assessing the coupling and shielding effectiveness properties of a wide range of cables.

The CCC01 design is based on the details of the "launcher" arrangement, described in IEC 96-1 Amendment 2 1993-06 section A.5.6 Line Injection Method (frequency domain). This arrangement is also used in IEC 62153-4-6: 2006 and mandated for the line injection method in EN 50289-1-6.



CCC01

Features

- **Fixed cable routes**
 - Repeatable layout of test and injection cables
- **Cable injection assemblies**
 - Injection cable runs are supplied preassembled and fitted with ferrite common mode chokes
- **Supports a range of test cable sizes**
 - 2.5 mm, 5 mm and 10 mm aperture cable supports provided as standard. Cable dimensions up to 22 mm x 13 mm are possible with the user-machinable fitting accessories.
- **0.3 m & 0.5 m test lengths**
 - Base plate allows the injection assemblies to be mounted either for a 0.3 m cable length (EN 50289-1-6) or the extended 0.5 m length (IEC 96-1) for increased coupling distance
- **Configurable injection conductor**
 - Self-adhesive copper tape, easily trimmed to the correct width required according to the circumference of the cable under test
- **Easy connection to test system**
 - Injection cables are terminated in N-type connectors

Applications

- **Cable shielding effectiveness measurements as indicated by:**
 - IEC 96-1 Amendment 2 1993-06
 - IEC 62153-4-6:2006
 - EN 50289-1-6
- **Investigation of cable coupling phenomena**

Specifications

| | |
|--------------------------|--|
| Frequency range | 10 kHz to 1 GHz typical (usable to higher frequencies, depending on the cables being tested and application of the test) |
| Output connectors | 50 Ω N-type sockets |
| Cable sizes | Approx. 2.5 mm to 10 mm diameter using the three sets of fittings supplied. User-machinable fittings available as accessories, supporting maximum cable dimension of 22 mm x 13 mm (rectangular cross-section) or 13 mm (diameter) |
| Dimensions | 220 mm × 880 mm (0.5 m test setting) 220 mm × 740 mm (0.3 m test setting) |
| Weight | 3 kg (typical excluding cable-under-test and any associated ferrites) |

Standard kits

| Part Number | Description | Parts included |
|-------------------|---|--|
| CCC01KIT01 | Standard CCC01 cable coupling clamp kit | <ul style="list-style-type: none"> • Pair of preassembled cable injection assemblies • Base plate with mounting positions for 0.3 m and 0.5 m cable test lengths • 2.5 mm, 5 mm and 10 mm diameter cable mounting fittings • Additional clip-on ferrite chokes • Self-adhesive copper tape (signal injection conductor) • Hard case for injection assemblies and accessories • Manual |

Note: We are unable to supply the cable under test (CUT), any parts associated with its construction and any ferrite rings to be fitted to it.

Accessories

| | |
|----------------|--|
| CMF01 | Kit of user-machinable blank fittings for custom cable apertures (single cable) |
| Special | Contact us for information regarding our testing service for cables to both IEC 96-1 and EN 50289-1-6, using the CCC01 |

CCC01 Example results

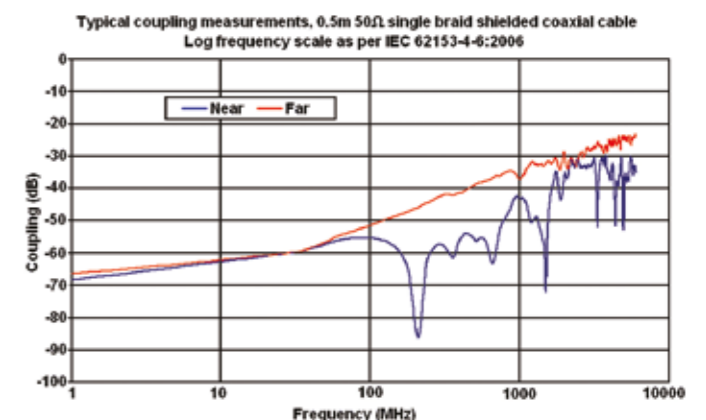
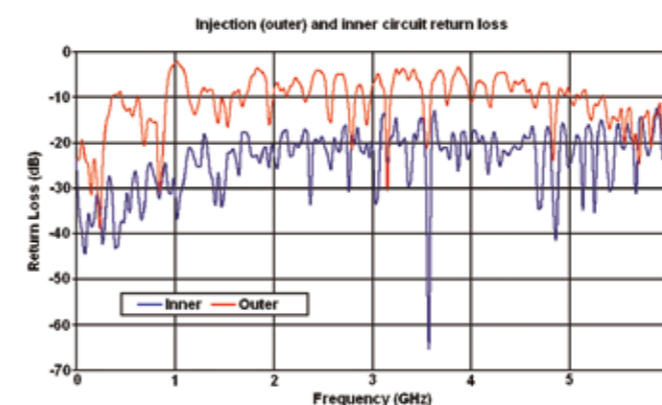
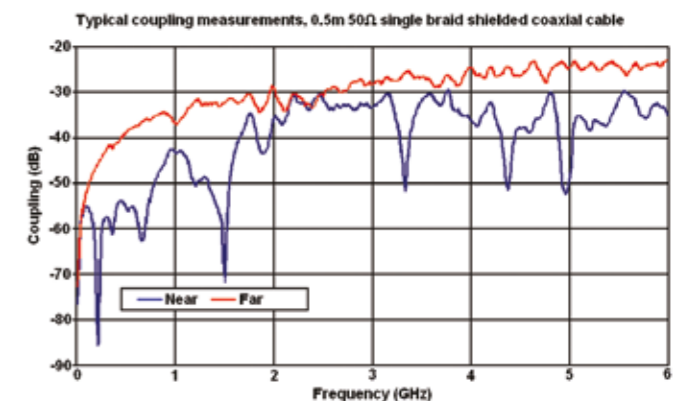
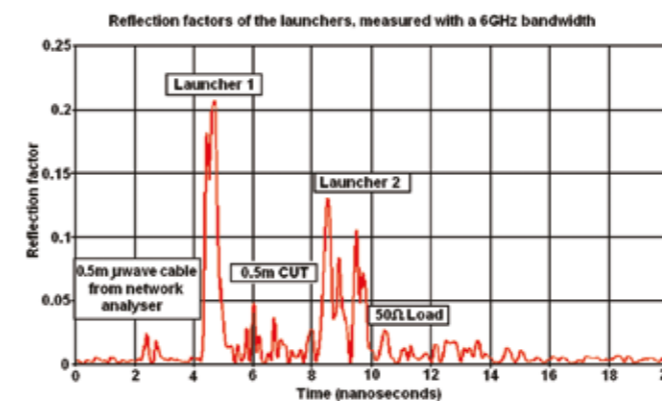

Pre-test checks how and why?

It is usual for the equipment used in an EMC test laboratory to be fully calibrated at periodic intervals. Such calibrations are typically undertaken annually, a trade-off between confidence in the accuracy of the equipment against the cost and downtime associated with the calibration process.

In the period between calibrations it is just as important to perform regular verification and monitoring of the particular test setups for the following reasons:

- The need for confidence in the operation of the test setup
- The need for confidence in the measurement equipment performance
- To provide continued monitoring of trends in system performance
- To provide repeatability data for uncertainty analysis
- To demonstrate compliance with the requirements of quality systems (e.g. ISO 17025)

This is especially important when equipment and facilities are used for performing several different tests, with equipment being assembled and disassembled frequently. When testing a novel piece of equipment with unknown characteristics, as is usually the case in commercial EMC testing, it is vital that the characteristics measured are of the equipment under test and not the unwitting result of, say, a loose connector somewhere in the measurement system. Pre-test checks have two requirements in addition to accuracy and repeatability:

- To be worthwhile, a pre-test check needs to allow as much of the complete test setup to be examined as possible.
- The test needs to be performed quickly so as to minimise the effective downtime.

Placing a single known reference signal or disturbance in place of the test subject addresses the first requirement. By placing the known source in-situ prior to the Equipment Under Test (EUT), any deviations from the expected performance can be identified. This also has the benefit of not requiring any extra setup time. In the case of emissions measurements, a simple verification might involve a single frequency spot check. This is certainly quick, however it might easily miss problems elsewhere across the frequency range. Multiple spot frequency measurements, such as those afforded by using the signals produced by a comb or harmonic generator are a significant improvement, but may still miss some of the finer detail. However, a wideband noise source allows such detail to be examined.

For thoroughness a pre-test check should ideally comprise the actual test to be performed on the EUT. However the second requirement, to minimise downtime, may make this impractical, so a stripped down version is usually more appropriate. Again taking the example of emissions testing, this could be a version of the test to be carried out on the EUT which uses a greater frequency step size, so introducing a sampling element but significantly reducing the time taken

to perform a measurement sweep. A pre-test check that only takes a few minutes to perform and produces worthwhile levels of confidence is more likely to be used than one that is long winded or prone to error.

The data taken from regular verification measurements should be recorded over time. Examination of these results will give valuable information on the following:

- Variations in day-to-day test setups
- Long term trends in measurement results
- Periodic trends in measurement results

Variation in day to day test setups are inevitable and are influenced by such factors as:

- Specific measurement equipment used, particularly if equipment is shared between different environments (e.g. a receiver used for an OATS and chamber tests) or reconfigured (e.g. if correction factors are loaded into the test equipment for direct application to the measurements)
- Ambient measurement conditions, such as temperature, humidity and/or cable positions.
- Measurement personnel, the "human factor".
- Small variations in test distances, especially important at > 1 GHz frequencies, but also important if the test environment exhibits irregularities, nulls or undamped resonances.

When these variations are examined then a random element can be extracted and fed into the measurement uncertainty budget for the given test.

Stable reference sources such as the York EMC Services' range of noise, comb and harmonics/flicker generators provide a flexible tool to aid in the verification of test systems. As an example a CNE, comparison noise emitter, can be used to monitor a radiated emissions test setup on a weekly basis over a year.

Procedure

This example shows the use of a CNE VI to validate a radiated emissions test setup in a fully anechoic room (FAR). The procedure involves simply placing the CNE VI in a prespecified position and running the standard emissions test (see Figures 1 and 2).

An ideal position for the reference source is the typical location of the EUT. In this example, the standard emissions test is carried out at a distance between the antenna and the EUT of 3 m, with the EUT elevated by 0.86 m on a non-conducting surface. To speed up the pre-test time, a modified version of the usual measurement test script can be used, with an increased step size of, say, between 1 and 5 MHz. This can reduce the pre-test time compared to a full EUT test, which may be significant when using older test equipment. In a commercial operation, a pre-test taking only a few minutes could be run whilst booking in the customer's equipment.

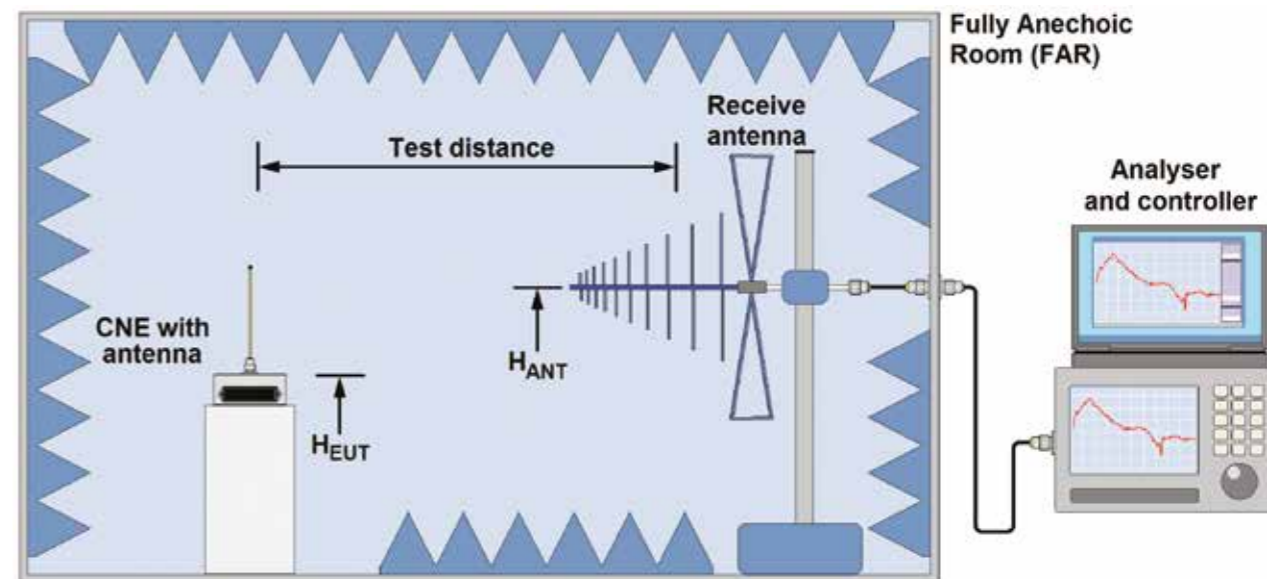

Figure 1. Radiated emissions pre-test check setup



Figure 2. Radiated emissions pre-test check in operation

Figure 3 shows a possible result of a regular weekly verification for a single frequency of a radiated emissions test. Here a noticeable long term drift in the measurement result can be seen superimposed on the random error. This long term trend could be due to, for example, the receiver ageing or to a gradual deterioration in the performance of the test site. In this case the information might also trigger an investigation into the cause of the drift and inform the planning process on replacement and refurbishment of equipment.

Figure 4 shows another example of a verification result plotted over time. In this case there can be seen both a

periodic trend and random element in the result. The periodic trend could be owing to seasonal temperature fluctuations for example. If the source of the drift can be identified and quantified then it may be possible to add a correction factor into the measurement. If the source cannot be quantified then it will be necessary to include the drift magnitude as a source of uncertainty in the stated measurement result.

It must be stressed that results such as these can only be meaningful if the source used for verification purposes is stable over all expected operating conditions and over time, characteristics inherent in the design of the York EMC Services' reference sources.

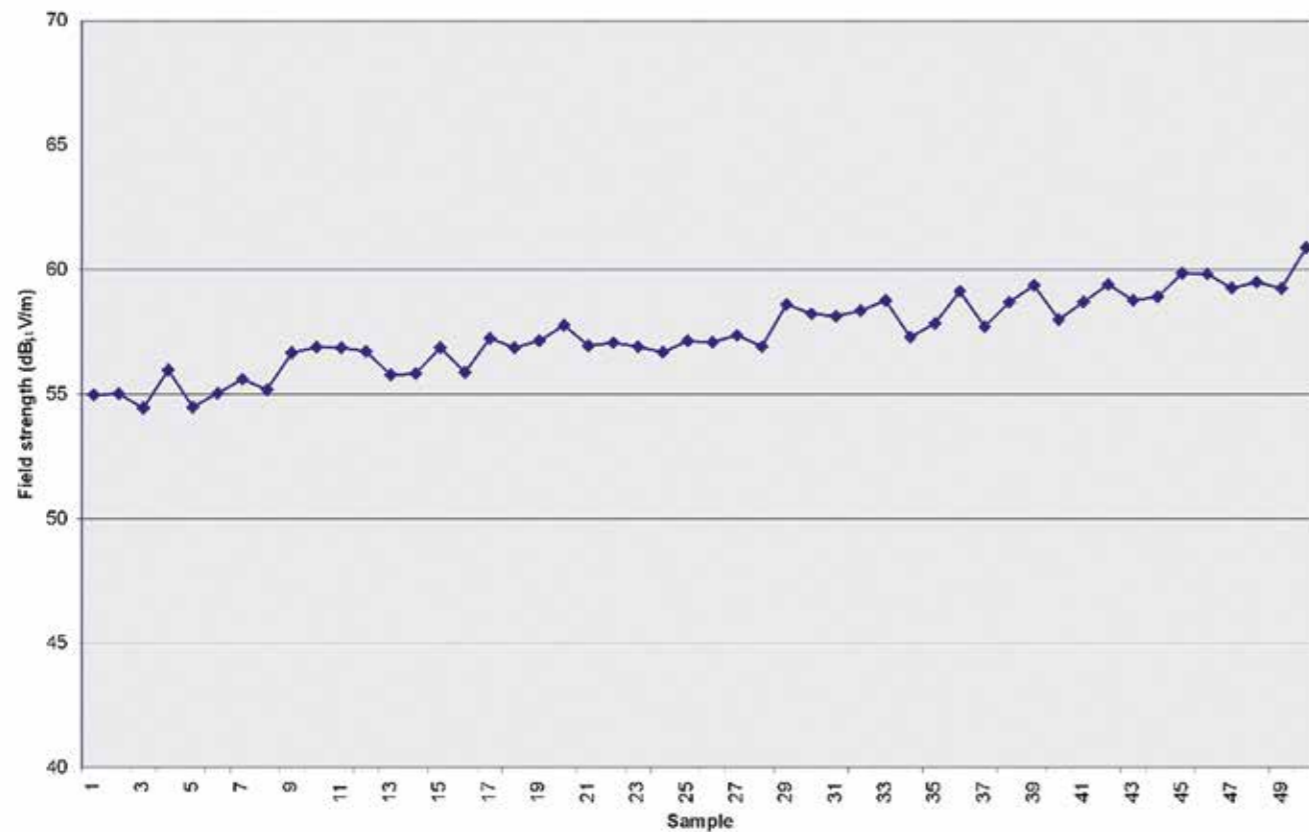

Figure 3. Sample measurements taken weekly

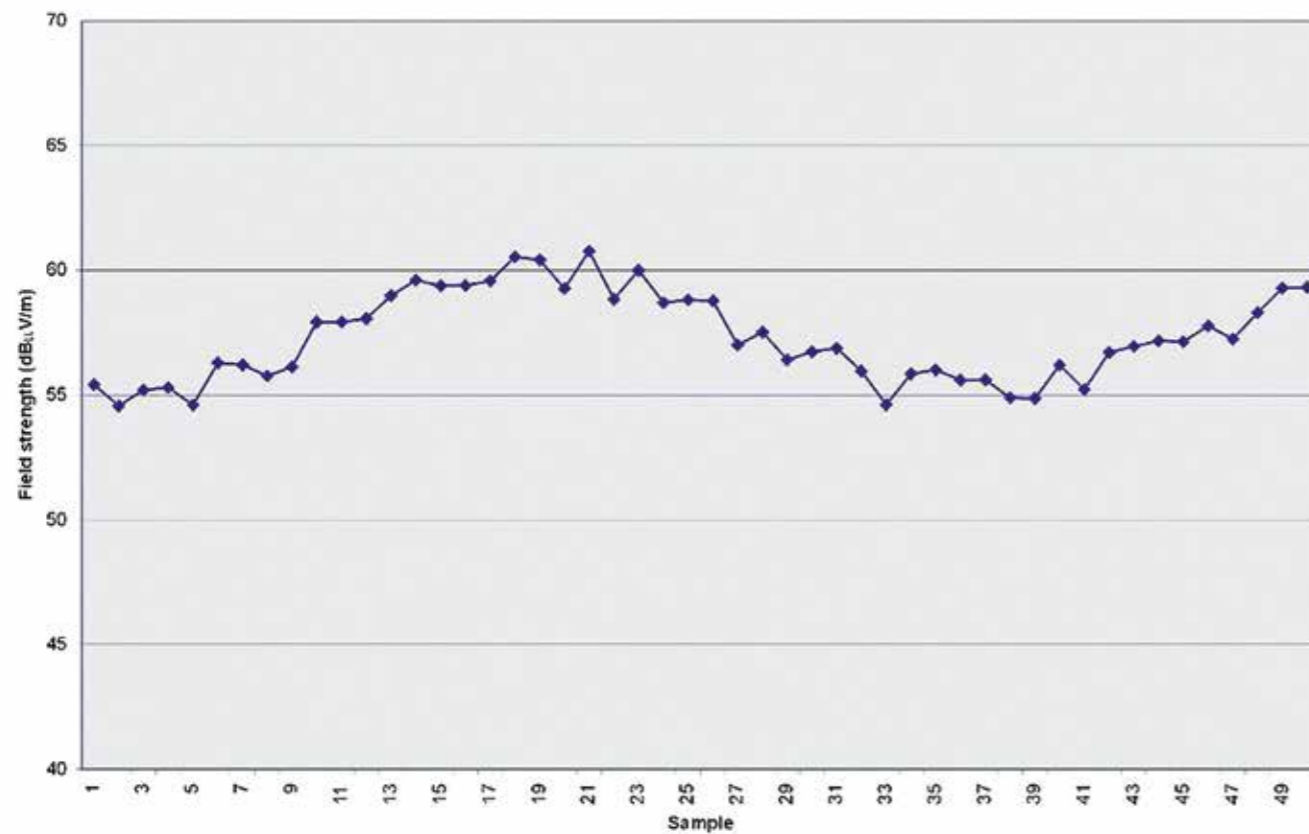

Figure 4. Sample measurements taken weekly

Examples of test setup problems identified using verification methods

The following three examples show the kind of problems with measurement setups that can be encountered in a working laboratory, which were identified by performing the kind of quick pre-test checks described (see “Pre-test Checks How and Why?” and “How to use an HFG to check harmonics and flicker test setups”).

Damaged measurement antenna in a fully anechoic room

Figure 1 shows the result of a radiated emissions verification made in a fully anechoic room. The verification measurement (grey line) differs significantly from the expected reference result (black line) over part of the frequency range. In this case damage to low-frequency elements of the measurement antenna was found to be responsible for the loss in performance.

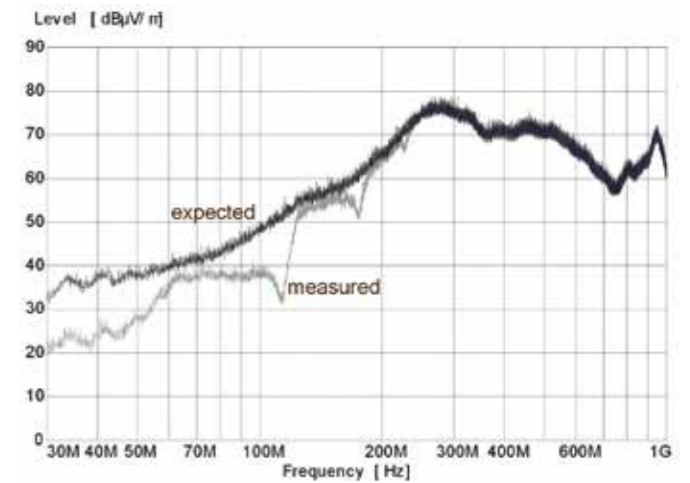

Figure 1. Damaged receive antenna used in an emissions setup

Water ingress into connectors on an OATS

The expected (based on previous measurements: grey line) and actual result of a verification on an OATS is shown in Figure 2. The unexpected readings (black line) and periodic variations in levels were traced to water ingress into an RF connector adaptor used for joining two cables together, introducing both transmission effects and mismatch errors. The resultant corrective actions included the withdrawing of the particular connector from service and the redesign of the weather protection for cable joints for this site.

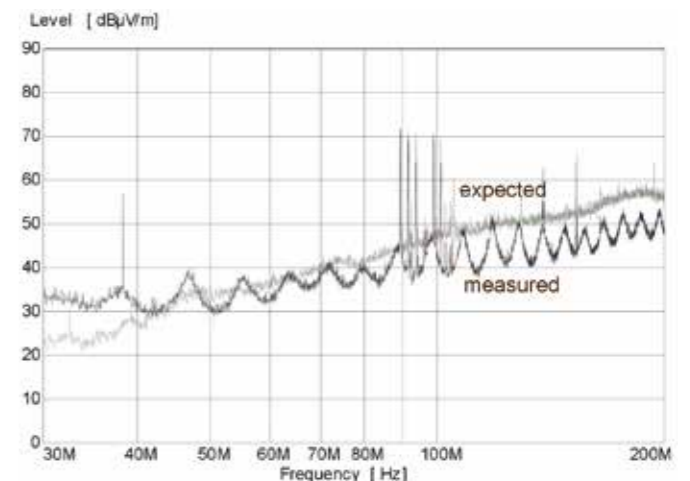

Figure 2. Effect of water ingress into a connector used on an OATS

Source impedance error in harmonics/flicker equipment

A comparison made using an HFG01 between a number of harmonics and flicker measurement setups used in different test facilities indicated a problem with several of them when measuring short term flicker (P_{st}). Figure 3 shows the variance in the results obtained, with test setup 3 taken as the reference norm. The accuracy limit required by EN 61000-3-3 is $\pm 8\%$. One result (not shown) yielded an error of over 300%, well outside the range of values given by the other setups.

Each test setup was built around separate items of equipment of various lineage, generally a “clean” supply source, an external reference source impedance and a harmonics/flicker analyser, all under the control of standard test software. In the case of the “rogue” measurement each item of equipment was fully within calibration and, when taken out of the setup and examined individually, appeared to be working satisfactorily.

The problem was traced to an incorrect source impedance being selected by the control software, which was not made clear to the operator. This problem was easily remedied by resetting the test software parameters, however a point noted was the spread in results achieved over all the test setups used. Apparently minor details, such as the quality/tightness of the connections to the reference

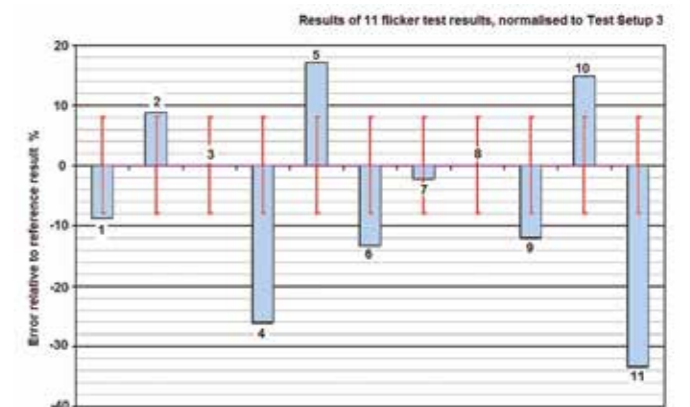

Figure 3. Variance in measurement across flicker tests

source impedance across which the voltage deviations are measured, conspire to increase the measurement uncertainty beyond what might be expected. In this case, the uncertainty of the whole is clearly greater than the apparent sum of the parts, and would only be noticed by exercising the system as a whole.

How to use a Comparison Noise Emitter (CNE) or York Reference Source (YRS) to check Line Impedance Stabilisation Network (LISN) performance

Conducted emissions verifications

As with other pre-test checks, the purpose of this exercise is to make an initial reference measurement on a system that is known to be good, and then to repeat the measurement at regular intervals to verify the continued correct operation.

A typical conducted emissions measurement e.g. CISPR 22 (EN 55022) uses a receiver or spectrum analyser to measure the RF emissions on the mains supply due to the equipment under test (EUT). The RF component is extracted from the mains supply using an Artificial Mains Network (AMN) or Line Impedance Stabilisation Network (LISN), which serves the dual role of providing a known source impedance and a means of coupling the mains borne RF into the (typically 50 Ω) measurement analyser (see Figure 1). LISNs are usually capable of selecting the mains conductor to be examined e.g. Live or Neutral for a single-phase device, referenced to either the equipment earth or to a separate measurement ground. Unlike receivers and analysers which include self calibration capabilities, LISNs require an external means of verifying their performance. Transient limiters are often included as well in the test setup to protect the measurement equipment and these also need to be checked to ensure that they do not introduce errors, for example following partial breakdown of the semiconductor.

Procedure

The verification or pre-test check performed is one of substitution. Figures 2 and 3 show a CNE noise source coupled to the LISN to verify the setup used in a laboratory mains power conducted emissions test. The earth lead attached to the LISN adaptor is required for protection purposes. When the LISN is plugged into the mains supply, a current of around 0.75 A flows through the safety earth due to the large capacitances between the current carrying conductors and earth.

One limitation imposed on this measurement is the need to protect the noise source from high voltages (see Note 1). For this reason it is highly recommended that the test is carried out with no mains supply to the LISN, or at least, only

to the LISNs control circuit (if applicable). Similarly, the LISN adapter couples the CNE signal to the neutral connection of an IEC 320 (EN 60320) plug so that, if the LISN has to be powered, only the relatively safe neutral is connected. Any cabling intended to couple the CNE to another mains supply system, or using other types of connector, must bear in mind this limitation.

Restricting signal injection to the neutral line, it is still possible to monitor the response of the LISNs live path due to the coupling between the live and neutral conductors in the mains cable used. The actual response gained will depend significantly on the cable itself, so using the same cable for repeat verifications is essential to making a worthwhile measurement.

Figure 4 shows the receiver output plot across the frequency range (peak and average detectors) for this verification measurement, which may be a subset of the intended test or, as in this case, a complete run through. A simple go/no-go comparison would be performed against the reference measurement to determine whether the test setup is satisfactory. This may be performed in software, by visual comparison, or by the introduction of limit boundaries on the printed graph.

Note 1: Under normal test conditions the LISN would be powered up, supplying mains voltage to the EUT. Although the LISN adapter provides some degree of protection, the need to provide good coupling for the RF signal from the reference source restricts the level of protection that can be applied.

Applying mains level voltages will damage the reference source. The UK mains supply employs a neutral connection that is connected to earth, for example at the distribution transformer. Allowing for cable voltage drops due to return current flow, this still results in a maximum permissible voltage on the neutral of around 6 V with respect to earth, and this may be enough to cause a soft failure of the reference source output stages over a period of time.

Some mains supplies around the world provide balanced live and neutral lines, as does the use of isolation transformers, so the option of choosing a low voltage conductor is not possible.

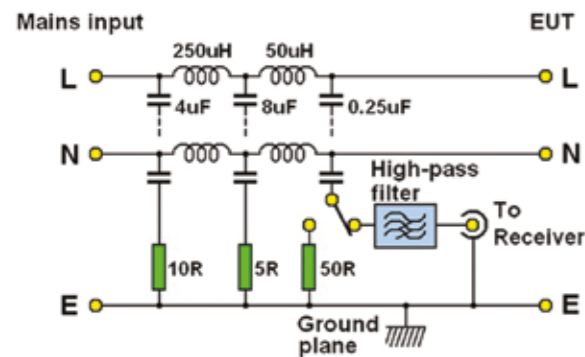

Figure 1. CISPR 16 Line Impedance Stabilisation Network

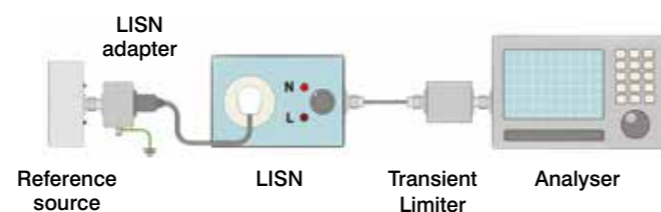

Figure 2. LISN verification setup using a CNE and LISN adapter



Figure 3. LISN verification setup using a CNE

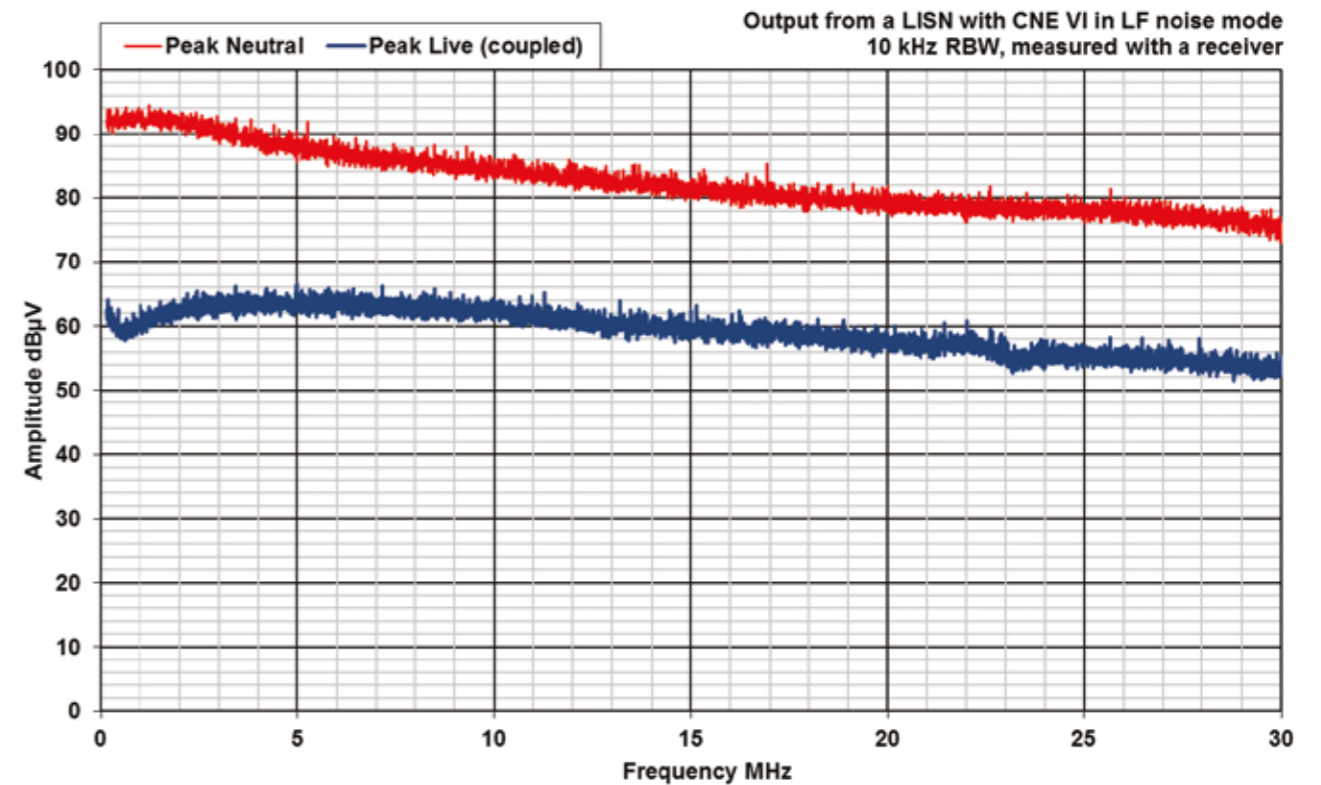

Figure 4. Peak and average measurements of LISN output using the test setup shown in Figure 3

How to use a Harmonics and Flicker Generator (HFG) to check harmonics and flicker test setup

The details of the methods described in the harmonics measurement standard (EN 61000-3-2) for determining the levels of harmonics and their associated limits mean that fully exercising the measuring equipment is only practical at periodic calibration intervals. Regular verification should be undertaken using equipment drawing a stable, harmonic rich current waveform.

The availability of proprietary sources for verifying and monitoring the performance of harmonics and flicker measuring equipment is limited, and some pre-test verifications are performed using "home made" solutions based on half-wave rectifiers and resistive loads. The stability of the resistive loads is called into question when temperature sensitive or non linear devices are used, such as filament lamps. In addition, half-wave rectifiers generate predominantly even-order harmonics. Most electronic equipment drawing current from the mains supply employs AC to DC conversion using full-wave rectification to feed a reservoir capacitor, and this topology generates predominantly odd-order harmonics. This may be significant when assessing the results or using the pre-test to exercise any test standards based software used to run the test setup and automatically assess the performance of the EUT.

For flicker measurements, the specification of the flickermeter described in IEC 61000-4-15 makes it difficult to predict the expected flicker from a known waveshape without extensive calculation and analysis. Hence the verification for this test is probably best left as a simple repeatability exercise using a source of disturbance.

In order to verify the flicker test the simplest method is to apply a known deviation at a stable repetition rate. This voltage deviation, which is the result of drawing current from a source with series impedance, can be generated by the regular switching of a stable resistive load, as shown in Figure 1. The resultant level of flicker disturbance is constant and repeatable and hence is suitable for a simple verification check on the flicker equipment. A deviation of around 0.3% is sufficient enough to produce significant flicker levels.

The HFG01 provides a number of load profiles intended to provide reference test results that can be used to verify correct test equipment operation. The four profiles provided are:

- a fixed current pulse, representative of the current drawn under full-wave rectification, which produces predominantly odd-order harmonics (see Figure 2).
- a current similar to the one above, but which fluctuates between narrow and wide pulse widths. The choice of pulse-widths reflects the equipment Class D description used in EN 61000-3-2 (prior to amendment A14) and is intended to exercise the "judgemental" aspects of some test software used to determine pass or fail verdicts.
- a resistive load switched in and out of circuit at a rate of 1 Hz, used to generate flicker.
- the same resistive load, but switched at a rate of 8.33 Hz. This produces the same level of voltage disturbance, but a greater degree of flicker than the 1 Hz mode.

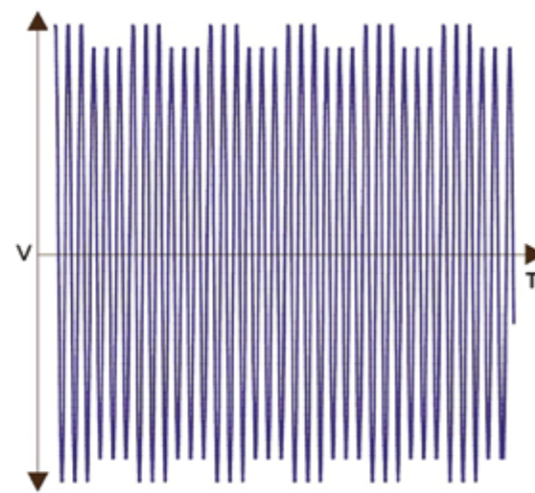
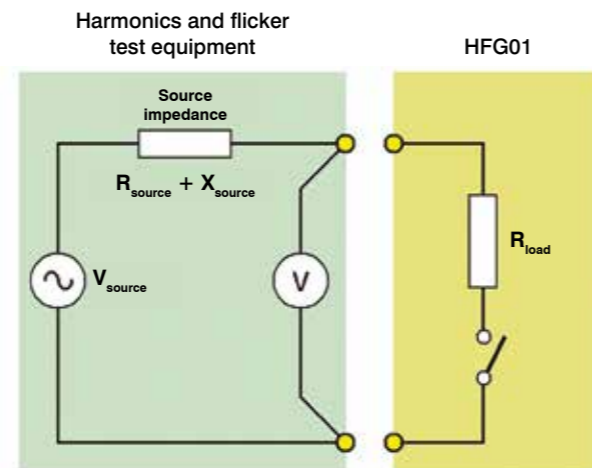

Figure 1. Generating flicker disturbance

Procedure

To perform the pre-test check the HFG01 is simply substituted in place of the EUT. This has the benefit of testing the total system; the power source, source impedance and power analyser. To assess the harmonics measurement, for example, either of the HFG01 harmonic modes is selected and the appropriate test then run. The test setup for such a verification is not usually critical, as at low frequencies the interactions with the environment are at sufficiently low levels so as not to interfere with the measurement result. A photograph showing a harmonics verification together with an example result can be seen in Figures 3 and 4.

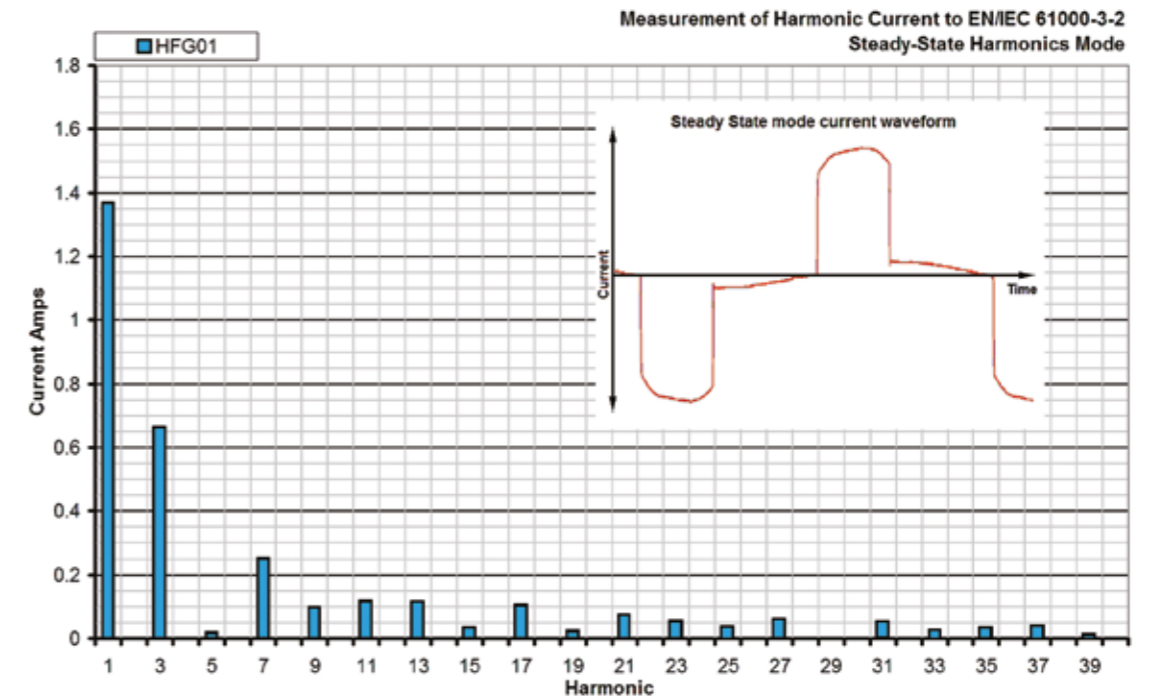

Figure 2. Fixed current pulse drawn by the HFG01 and its resultant harmonic spectrum



Figure 3. Harmonics pre-test using the HFG01 as the reference load



Figure 4. Results from the harmonics test software.

As can be seen, the harmonic currents generated are close to the acceptable limit in several places. In fluctuating harmonics mode the two current pulse widths straddle the points used to define the Class D category in EN 61000-3-2:1995, and this mode would be expected to result in a Class D fail verdict (although it may alternatively be reported as a Class A pass depending on the test software configuration).

For flicker measurements, the two settings are designed to provide a pass and fail response from the test software. Although the same level of voltage disturbance is generated in both cases, when applied at 1 Hz this should result in a short term flicker (P_{st}) of < 1 , whereas at 8.33 Hz this should result in a $P_{st} > 1$, due to the human model of perceived "annoyance" being most sensitive around 8 Hz.

There are several issues that can arise when performing such measurements. Notably, there appears to be a large degree of measurement uncertainty associated with these tests. Sensitivity to the quality of connections used around the source impedance is one area of potential inaccuracy,

given the low value of the reference impedance itself. In addition, the power source needs to produce a sinusoidal voltage of very high quality under all load conditions. Attempting to perform a harmonics test using a voltage supply derived from the mains (e.g. through an isolation transformer or power filter) is unlikely to be adequate. Other easily made errors include setting the wrong frequency (60 Hz instead of 50 Hz) or voltage (110 Vac instead of 230 Vac) on the power source.

Should discrepancies arise between tests, each element of the test setup would need to be examined. If, for example, the flicker P_{st} value has changed, but the voltage deviation has not, then has the calculation changed in any way? Or, if the voltage deviation has changed, this could indicate a change in either the source or the source impedance, of which the source can be checked in isolation, under load conditions, using standard laboratory equipment.

The HFG01 is designed to run solely from a 230 Vac, 50 Hz supply and any deviations from this will inevitably affect the harmonic spectrum or flicker levels produced.

How to use a Comparison Noise Emitter (CNE) to measure filter response

Perhaps the best way for most of us to identify the characteristics of a filter is to use a network analyser, which allows the transmission (S_{21} and S_{12}) and reflection (S_{11} and S_{22}) coefficients to be measured accurately. However, for many EMC laboratories a network analyser may not be a standard piece of equipment and its cost is unlikely to be justified by simply carrying out cable or filter checks.

A simple measurement of the frequency response (or the forward transmission coefficient, S_{21}) is usually sufficient to tell us whether or not the filter is behaving as expected. For this, a spectrum analyser with a tracking generator is a good solution, but again these are not common tools to have to hand. Using a "standard" spectrum analyser with a separate signal generator is painstakingly laborious, unless "spot" checks alone are carried out or an ATE process is used.

A quicker alternative is to use a wideband signal source such as the Comparison Noise Emitter (CNE), commonly used in EMC test laboratories as a reference source for a range of pre-test checks. This allows a rapid evaluation of the filter's performance to be made by substitution, using a standard spectrum analyser.

Procedure

In addition to the Filter Under Test (FUT), a CNE, a spectrum analyser (ideally one with a "Trace A minus Trace B" or similar mathematical difference function) and an attenuator (10 dB or 20 dB) are needed.

Figure 1 shows a measurement being made of a 100 MHz lowpass filter. The purple trace in the background shows the direct output of the CNE III being used, with the yellow trace showing the filtered signal. At this stage the Trace A-Trace B difference function is not being used, but the filter characteristic is still clear.

To perform the test, connect the CNE, attenuator and analyser as shown in Figure 2. With the analyser set to cover the frequency range of concern, store the result in one of the trace memories (Trace B in this example) to record the baseline response of the CNE, attenuator and cable.

Insert the FUT between the attenuator and the analyser and repeat the measurement. With the analyser set to display the difference (A-B in this example), you can quickly see the forward transmission characteristic of the filter.

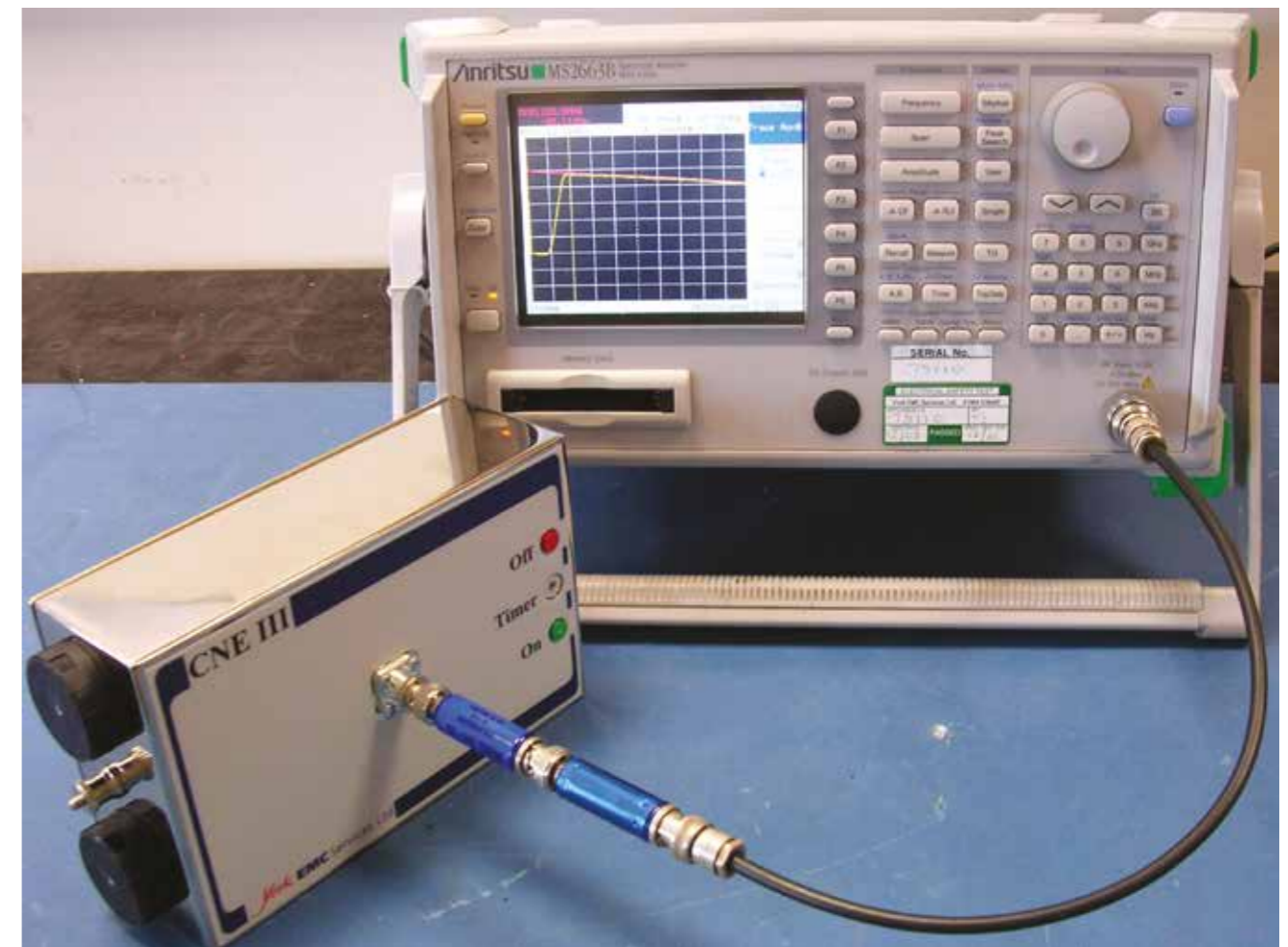

Figure 1. Measurement of 100 MHz high-pass filter using a CNE III

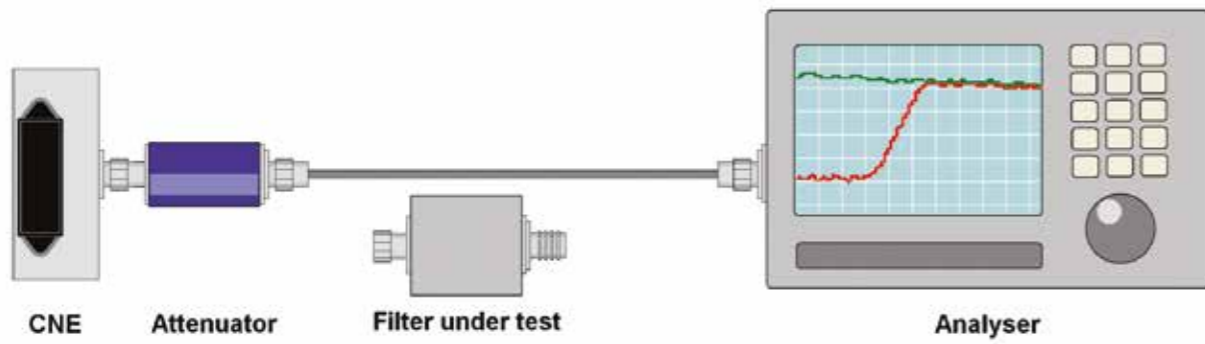

Figure 2. Filter test by substitution setup

If the spectrum analyser has no equivalent built-in difference function, then this can alternatively be carried out by exporting the data to a spreadsheet for manipulation.

This is straightforward enough, but there are a couple of points to note:

- Since the CNE signal is noise, averaging the measurement is recommended to produce a smoother, more usable trace. Use an averaging function (which most analysers have) over, say, 25 or more sweeps. Alternatively, turn the video bandwidth setting as low as it can go, although this latter approach can slow the measurement unacceptably.
- Why the external attenuator, when it reduces the dynamic range of the measurement? In the case of a non-absorptive FUT, signals in the stop-band are reflected back into the CNE. Most of this signal will be "lost" within the CNE, but some will be re-amplified and retransmitted to the FUT. The result is that there will be more signal appearing in the stop-band than there should be, giving a false impression of how good the filter's rejection performance is. An external attenuator of 10 dB or 20 dB reduces this effect significantly (by improving the impedance matching and by effectively

attenuating such reflected signals twice), so that although the dynamic range (the difference between the measured signal from the CNE and the analyser's noise-floor) is reduced, a greater stop-band rejection can be accurately measured. Since the stop-band "mis-match" exists on the output of the FUT as well, it's prudent to include attenuation in the analyser settings as well. The graphs in Figure 3 and Figure 4 show the difference in results taken using different levels of external attenuation when measuring a couple of standard, off-the-shelf commercial filters with a CNE III. **Note:** YRS and CNE VI generators have better output matching, so this effect is much less.

- Reflections are less of a factor for absorptive filters, which can be treated differently. Figure 5 shows the performance of a custom built bandpass filter, which was specifically designed to be absorptive in the stop-bands. This means that external attenuation is largely unnecessary and can be dispensed with to increase the dynamic measurement range. In each of the traces shown, the stop-band response displayed is dictated by the analyser noise-floor.
- Note that in all cases the reported frequency response of the filter is unchanged, with cut-off and cut-on frequencies accurately represented irrespective of those changes made to improve stop-band readings.

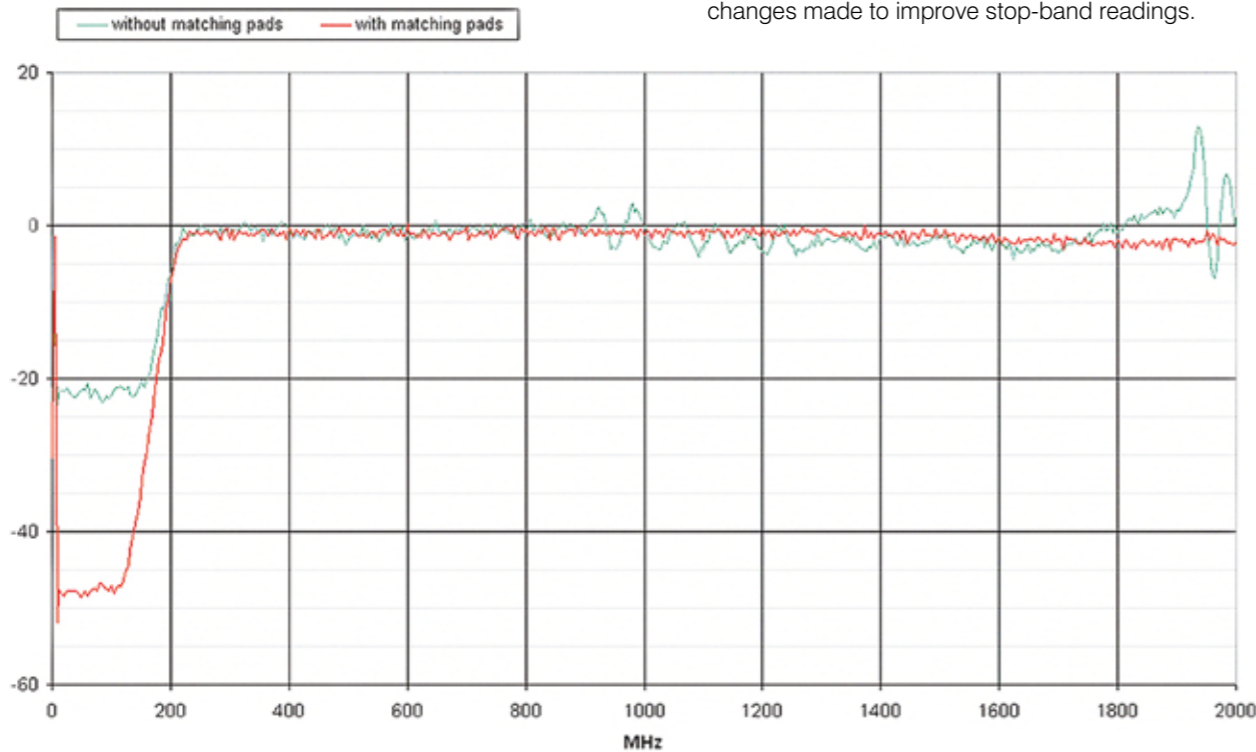

Figure 3. 250 MHz high-pass filter measurement

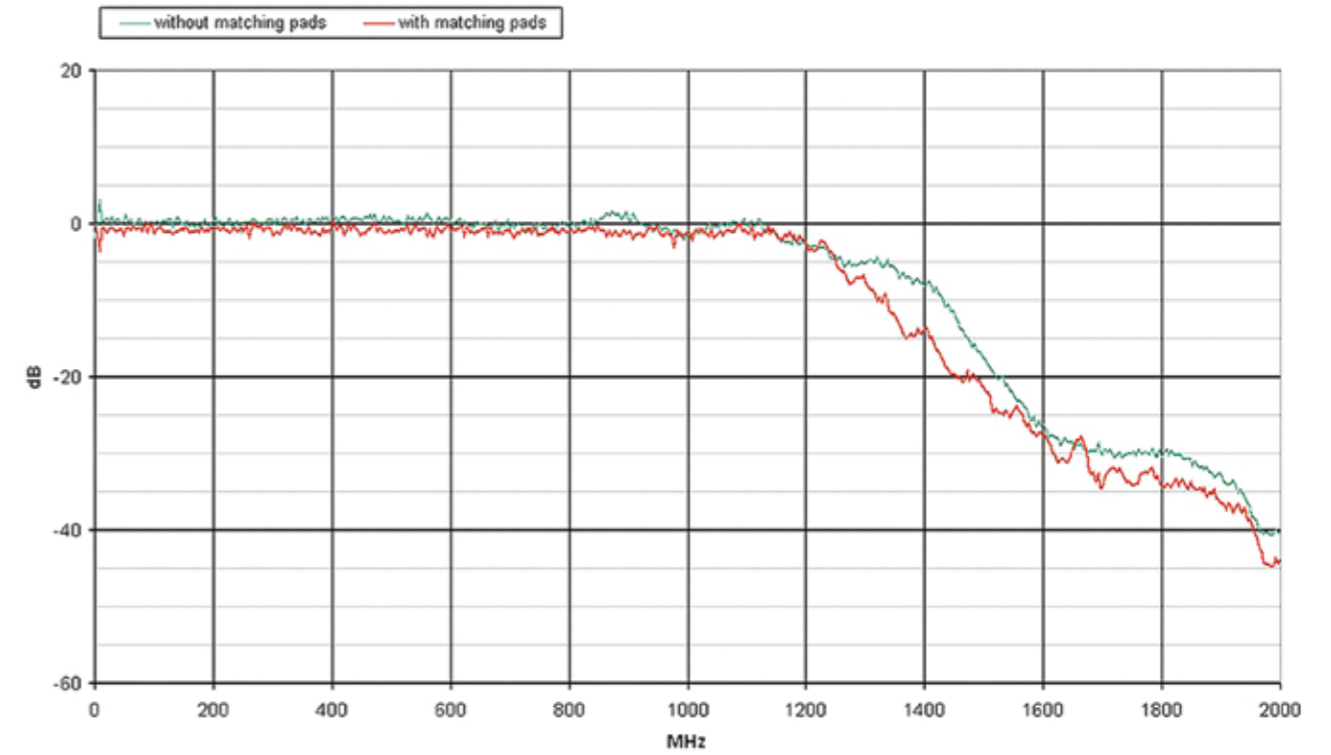

Figure 4. 1200 MHz low-pass filter measurement

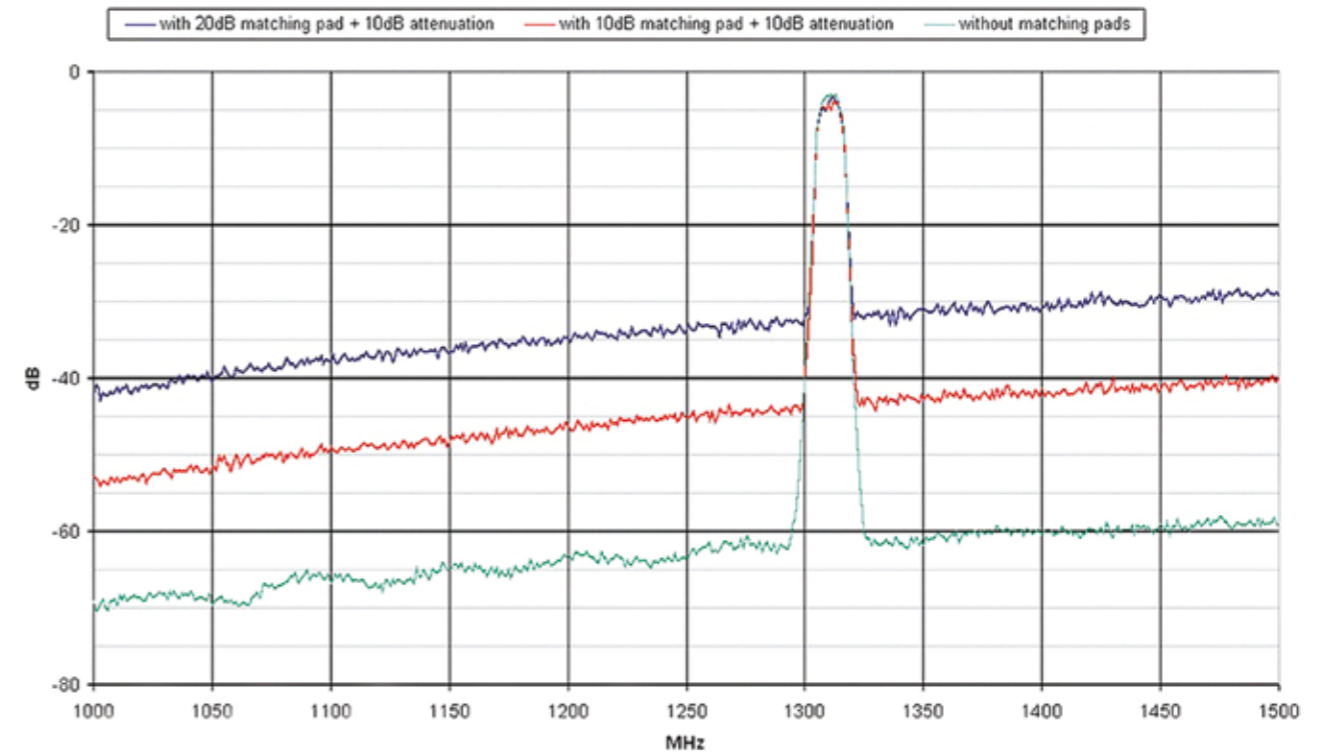

Figure 5. 1307 MHz band-pass filter measurement

How to convert dBμV/m test results into Effective Isotropic Radiated Power (EIRP)

Test results for the radiated signal performance of York EMC Services' reference signal generators are supplied in terms of the electric field strength, the units of which are dBμV/m, as this is the common measurement used for EMC emissions tests.

In some cases, for example antenna link calculations, it can be useful to know what the effective isotropic radiated power (EIRP) is. This is a measurement of the power radiated from the source and it can be derived, given a couple of assumptions, from the value given for the electric field strength.

Procedure

The first assumption relates to the measurement environment, namely that it is occurring in free space. Reflections from nearby objects, or the attenuation of the signal by anything other than distance, are not accounted for. A good Fully Anechoic Room (FAR) gives this kind of environment, an Open Area Test Site (OATS) less so because of complications like ground-plane reflections. With this in mind, the basic situation is shown in Figure 1.

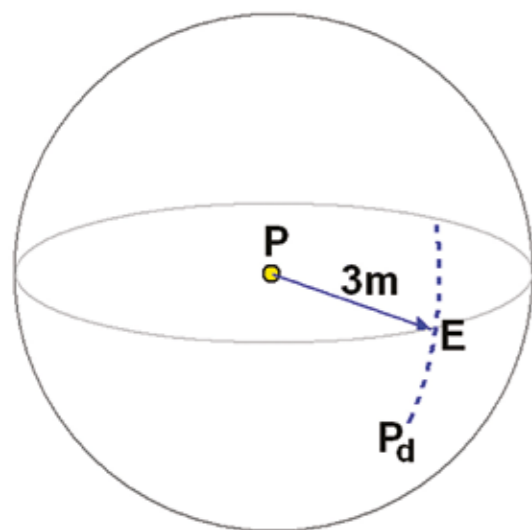

Figure 1. Basic relationship between radiated power and field strength Where P = power (W), E = electric field strength (V/m) and P_d = power density (W/m²)

This highlights the second assumption made, namely that the source is isotropic, radiating equally in all directions. This is not the case for a CNE or CGE using their respective standard monopole and monocone antennas, as they produce a "doughnut"-like radiation pattern. Other antennas exhibit their own non-isotropic radiation patterns. For example, a horn antenna has a highly focussed beamwidth which, in the case of a transmitting antenna, concentrates the power entering it over a small fraction of the total area of the theoretical sphere illustrated above. In this case, because it would be assumed that the same power is

being transmitted in all directions, the EIRP is much higher than the actual input power, which in turn leads to the gain characteristic of the antenna. As such, the EIRP calculated for a non-isotropic antenna is valid only for the particular arrangement of the transmit and receive antennas used to make the measurement.

So, making the assumption that the source is transmitting equally in all directions, the power reaching any point on the sphere described by the measurement distance is;

$$\text{Power Density } P_d = \frac{P}{4 \times \pi \times r^2}$$

Where P is measured in watts and $r = 3 \text{ m}$ in this case.

The power density is also defined by the field strength E and the free-space impedance Z_0 ;

$$\text{Power Density } P_d = \frac{E^2}{Z_0}$$

where E is measured in V/m and $Z_0 = 120\pi$ or approximately 377 Ω. Combining these two gives;

$$\frac{P}{4 \times \pi \times r^2} = \frac{E^2}{120\pi} \quad \text{which rearranged to;}$$

$$P = \frac{E^2 \times 4 \times \pi \times 3^2}{120\pi} \quad \text{simplifying to;}$$

$$P = E^2 \times 0.3$$

It is usual to define the power and field strength in terms of dBm and dBμV/m. Defining E in μV/m gives;

$$P = \left(\frac{E}{10^6}\right) \times 0.3 = E^2 \times \frac{0.3}{10^{12}}$$

Changing P from watts to dBW gives;

$$P_{(dBW)} = 10 \log P_{(W)} = 10 \log \left(E^2 \times \frac{0.3}{10^{12}}\right)$$

$$P_{(dBW)} = 20 \log E + 10 \log \left(\frac{0.3}{10^{12}}\right)$$

which, since this refers to E in terms of μV/m, equates to;

$$P_{(dBW)} = E_{(dB\mu V/m)} - 125.2$$

Finally, to give the conversion in terms of dBm, where 30 dBm = 1 dBW

$$P_{(dBm)} = E_{(dB\mu V/m)} - 95.2$$

In summary, bearing in mind the assumptions being made, the Effective Isotropic Radiated Power can be derived from the 3 m field strength test measurements supplied with the CNE and CGE reference sources by subtracting 95.2 from the numerical value given in dBμV/m. By following the same process for the case of 10 m test measurements, 84.8 should be subtracted instead.

How to use a CCC01 to measure cable shielding effectiveness through transfer impedance

The CCC01 is based on the design described in IEC 96-1 Amendment 2:1993, also used in IEC 62153-4-6:2006 and mandated for the line injection method in EN 50289-1-6.

EN 50289-1-6:2002 states "The transfer impedance Z_T of an electrically short uniform cable is defined as the quotient of longitudinal voltage induced in the outer circuit due to the current in the inner circuit or vice versa, related to unit length". York EMC Services has historically measured Z_T "vice versa", and this method will be described here.

The transfer impedance definition can be summarised as:

$$Z_T = \frac{V_L}{I_{SH} L}$$

V_L (longitudinal voltage) is the voltage between points 1 and 2 on the inner conductor (Figure 1). I_{SH} is the shield current and L is the coupled length. As it is impractical to measure V_L directly the voltage measurement is made across the load impedance as indicated. Normally values of Z_T are given in W/m.

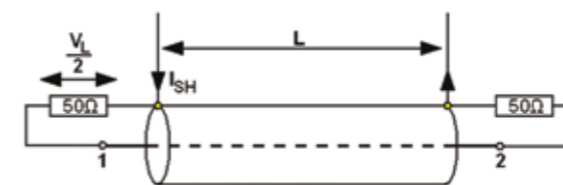

Figure 1. Theoretical arrangement for measuring Z_T

Description of the line injection method

A schematic diagram of the line injection method is shown in Figure 2. This is the simplest method of achieving the theoretical arrangement described above.

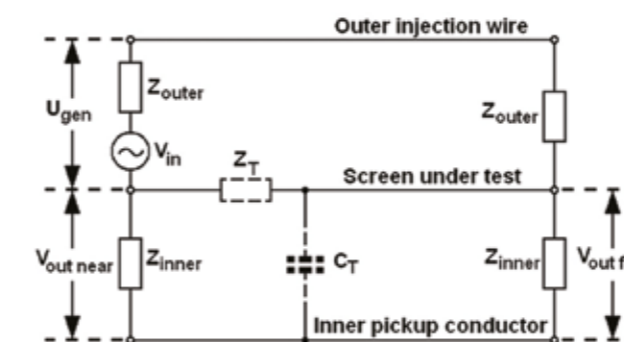

Figure 2. Schematic diagram of line injection method

To ensure both inner and outer circuits of the line injection arrangement are matched, the transmission line comprising the outer injection wire and the screen under test must have a characteristic impedance (Z_0) of Z_{OUTER} . Similarly, Z_0 for the transmission line of the screen under test and the inner pick up conductor should equal Z_{INNER} .

Required test instrumentation

The measurement of Z_T is most easily achieved by using a Network Analyser. For example an Agilent 8753ES 30 kHz to 6 GHz model gives a dynamic range ~100 dB (allowing ~100 dB of shielding to be measured without using additional amplifiers) and high immunity to external noise sources. The optional time domain upgrade also allows the reflection factor of the CCC01 "launchers" to be measured easily.

High quality microwave cables with N-type connectors are needed to connect the network analyser to the CCC01. Unwanted coupling through the screens of low quality coaxial cables may affect the measurement. Similarly, good quality 50 Ω loads are needed.

The measurement of a 50 Ω coaxial cable is described here. Cables with different characteristic impedances can be measured, but require special consideration.

The CCC01 can be configured to provide a coupling length of either 0.5 m or 0.3 m. The standards provide a formula for calculating the maximum cable length for a given frequency, based on the assumption that the sample must be electrically short at the frequency of interest. For IEC 62153-4-6:2006 the formula is:

$$f_{max} \leq \frac{c}{\pi \times L_{max} \sqrt{\epsilon_{r2} \pm \sqrt{\epsilon_{r1}}}}$$

where;

- ϵ_{r1} is the relative permittivity of the dielectric of the injection circuit;
- ϵ_{r2} is the relative permittivity of the cable dielectric;
- \pm refers to near/far end measurement (+near, -far);
- c is the velocity of light, $3 \times 10^8 \text{ m/s}$;
- f_{max} is the highest frequency to be measured in Hz;
- L_{max} is the maximum coupled length in m.

For example assuming a relative permittivity of the cable jacket (ϵ_{r1}) of 2.7 (pure PVC) and a relative permittivity of the cable inner dielectric (ϵ_{r2}) of 3.8 (pure Nylon), the results of the calculation are summarised in Table 1.

| Theoretical f_{max} | $L_{max} = 0.3 \text{ m}$ | $L_{max} = 0.5 \text{ m}$ |
|------------------------------|---------------------------|---------------------------|
| Near end measurements | 88.6 MHz | 53.2 MHz |
| Far end measurements | 1.04 GHz | 623.7 MHz |

Table 1. f_{max} vs L_{max} , from IEC 62153-4-6:2006

In practice one of the features of the jig is that samples can be electrically long, with little standing wave disturbance for far end measurements, so calculated values of electrical length are not as important as suggested by the standards. Slightly improved return loss on the injection circuit might be obtained for a 0.3 m sample, whereas a 0.5 m sample gives increased coupling. For well screened cables the latter makes the measurement dynamic range requirements slightly less onerous. In this example a coupled length of 0.5 m is used, requiring a 1 m test cable terminated with N-type connectors.

The preparation of the test cable is covered in detail in the CCC01 Operation Manual. Once the test cable is fitted into the CCC01, the injection circuit must be added and this is most easily implemented by attaching adhesive copper foil to the test cable jacket.

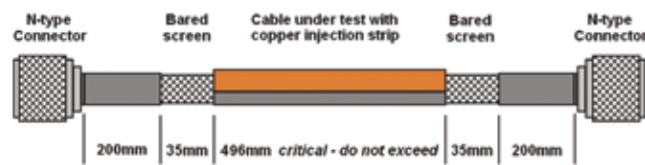

Figure 3. Prepared test sample with injection strip

The characteristic impedance of the injection circuit is adjusted by altering the foil strip width. For guidance, the following formula derived from Kraus^[1] is useful, where W = width of strip and H = height above shield, normally ~ 1 mm for a typical cable jacket):

$$\frac{W}{H} = \frac{377}{\sqrt{\epsilon_r} Z_0} - 2$$

This gives a strip width of 2.5 mm for $\epsilon_r = 2.7$ (PVC) and $Z_0 = 50 \Omega$. It should be noted that the text book value of ϵ_r given for PVC is unlikely to be correct due to variations in manufacturing processes and polymer "recipes".

Once the width of the injection strip is decided it should be fitted and soldered to the wires protruding from the launchers as shown in Figure 4.



Figure 4. Injection strip fitted to Cable Under Test (CUT)

Example measurements

According to IEC 62153-4-6:2006 the injection circuit should be matched to give a return loss of better than 20 dB (i.e. a reflection factor at each launcher < 0.1). This is achievable for frequencies up to a few hundred MHz, but by 1 GHz this is not possible. Figure 5 shows typical return loss measurements on the outer injection and the inner circuits. If available on the network analyser, the time transform option can be used to locate the regions where mismatch is the greatest and if appropriate, improvements can be made by altering the copper tape width or height.

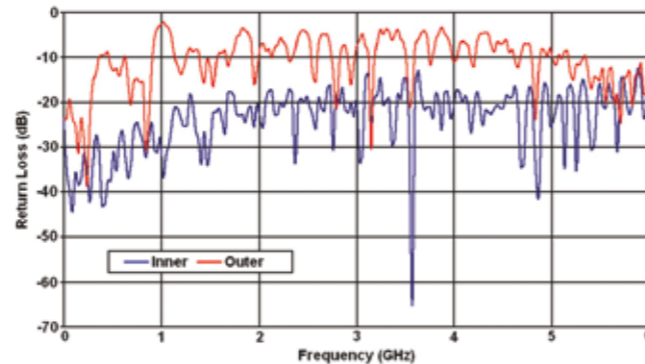

Figure 5. Injection (outer) and inner circuit return loss

Measurements of coupling

Measurements of coupling can be made at the "near" end or far "end". Figure 6 shows the CCC01 configured for a near end measurement. Figure 7 shows the raw results for near and far end coupling measurements. As can be seen, the far end measurements are generally greater than those at the near end, and furthermore are generally free from major disturbance from standing wave effects.

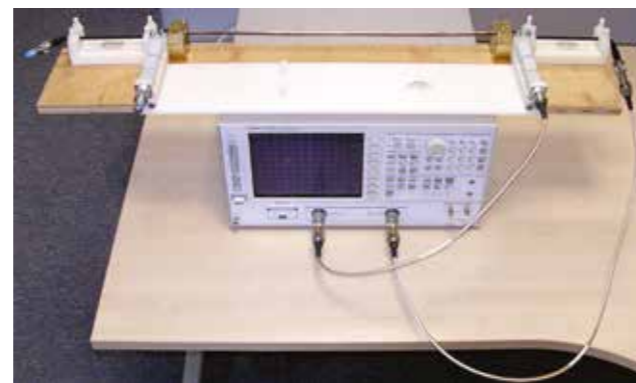

Figure 6. CCC01 configured for a "near" end coupling measurement

IEC 62153-4-6:2006 requires that both near and far end measurements are made. However, as shown in Figure 7 and discussed later, for high frequency measurements (above 50 MHz) it is likely that near end measurements will have too much resonant structure to be valid. In such cases it is reasonable to measure Z_T above 50 MHz using far end measurements only.

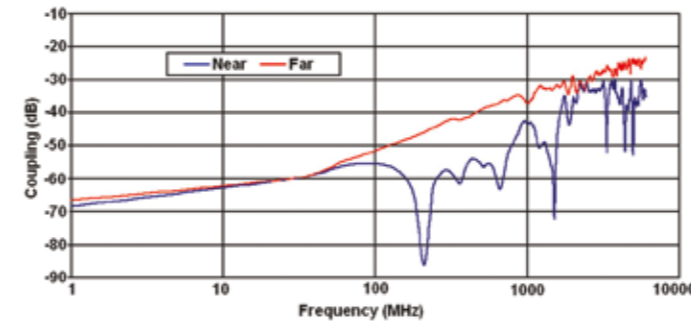

Figure 7. Typical coupling measurement results using log frequency scale as per IEC 62153-4-6:2006

For IEC 62153-4-6:2006 at least four measurements should be made, with the test cable rotated in the clamp each time (i.e. $0^\circ, 90^\circ, 180^\circ, 270^\circ$). This is to identify any seams in the shield, as would occur with a foil shield.

Treatment of Results

The network analyser measurements of S_{21} can be used to derive Z_{TE} (Equivalent Transfer Impedance).

Z_T is a measurement of inductive coupling. If the shield is loosely braided then some capacitive coupling will also be measured. The inductive and capacitive parts of the coupling cannot be separated so the standards define the parameter Z_{TE} that comprises both inductive and capacitive coupling (should it be present). IEC 62153-4-6:2006 requires that results give Z_{TE} in units of ohms per unit length.

Z_{TE} from S_{21} in accordance with IEC 62153-4-6:2006

Equation (17) of IEC 62153-4-6:2006 states:

$$Z_{TE} = \frac{2R_2}{L_c \times k_m} 10^{\left(\frac{-A_r}{20}\right)}$$

where for our example 50 Ω coaxial cable

$$A_r = 20 \log_{10} \left(\frac{U_{gen}}{U_{rec}} \right)$$

$$\begin{aligned} R_2 &= 50 \Omega \text{ (load resistance)} \\ L_c &= 0.5 \text{ m (the coupled length)} \\ k_m &= 1 \text{ (matching network voltage gain -} \\ &\text{nonexistent in our example so } k_m = 1) \end{aligned}$$

U_{gen} is shown on Figure 2 and U_{rec} corresponds to V_{OUTFAR} or $V_{OUTNEAR}$ on that diagram.

Expressing Equation (17) in dB for our example:

$$Z_{TE} \text{ (dB}\Omega/\text{m)} = 46 \text{ dB} + U_{rec} \text{ (dB}\mu\text{V)} - U_{gen} \text{ (dB}\mu\text{V)}$$

Due to the definition of S_{21} :

$$S_{21} \text{ (dB)} = U_{rec} \text{ (dB}\mu\text{V)} - U_{gen} \text{ (dB}\mu\text{V)}$$

$$\text{Thus: } Z_{TE} \text{ (dB}\Omega/\text{m)} = S_{21} \text{ (dB)} + 46$$

So to express Z_{TE} in line with IEC 62153-4-6:2006 for the example 0.5 m long 50 Ω coaxial cable, add 46 dB to the S_{21} measurement.

References

- [1] Kraus/Fleisch, *Electromagnetics with Applications*, fifth edition, 1999, ISBN 0-07-116429-4, McGraw-Hill International Editions

Glossary

| | |
|--|---|
| ARA | Active Receive Antenna |
| Bilog™ | Industry standard passive wideband antenna combining biconical and log-periodic elements |
| BNC | A bayonet fitting type of RF connector used for terminating coaxial cable |
| CCC | Cable Coupling Clamp |
| CGE | Comb Generator Emitter |
| CISPR | Special International Committee on Radio Interference (abbreviated CISPR from the French name of the organization, Comité international spécial des perturbations radioélectriques) |
| CNE | Comparison Noise Emitter |
| DAE | Dipole Antenna Elements |
| Direct Output | The output power of a device measured directly at the connector (conducted output) |
| EIRP | Effective Isotropic Radiated Power |
| EMC | Electromagnetic Compatibility |
| EN | EuroNorm – European Standards |
| EUT | Equipment Under Test |
| FAR | Fully Anechoic Room (the same as an anechoic chamber) |
| FUT | Filter Under Test |
| HFG | Harmonics and Flicker Generator |
| IEC | International Electrotechnical Commission |
| ISO | International Standards Organisation |
| LISN | Line Impedance Stabilisation Network |
| OATS | Open Area Test Site |
| P_{st} | Perception of Flicker, short term. A measure of flicker severity expressed as irritation, with an P _{st} value of 1 being threshold of irritation |
| RF | Radio Frequency |
| Radiated Output | The radiated electric field of a device measured at a specified distance |
| S₁₁ S₁₂ S₂₁ S₂₂ | Transmission and reflection coefficients for a filter |
| SAC | Semi Anechoic Room |
| SMA | Threaded RF connector "SubMiniature version A" |
| SS & FL | Steady State and Fluctuating harmonics modes on HFG01 as specified by EN/IEC 61000-3-2 |
| VSWR | Voltage Standing Wave Ratio |
| YRS | York Reference Source multimode Comb and Noise Generator emitter |

General Information

Ordering Information

Standard order kits are listed for each product in this brochure. Please refer to the appropriate part number when requesting a quote for a test instrument or accessory. If you require a non-standard instrument kit or accessory, or if you would like further information before making your choice, please contact our sales or products staff, or your local representative.

Hire of Test Instruments

Hire of our test instruments can be arranged, subject to availability. Hire terms are typically on a weekly basis. Please contact our sales staff or your local representative for details on pricing and availability.

Test and Repair Service

Where applicable, test instruments are shipped with performance test results. Details of the tests performed are listed with each product. No expiry date is issued with these results. York EMC Services provides a retest service, if the customer requires updated performance data. Please refer to the order codes when requesting a quotation for this service.

A repair service covering faulty or damaged York EMC Services test instruments is available. Each case is examined individually, with quotations for repair and retest issued as appropriate. Please contact our sales or products staff or your local representative in the first instance.

Sales Office Hours

Our UK head office hours are: 9:00-17:00, Monday to Friday

Tel: +44 (0) 1904 324440
Fax: +44 (0) 1904 324434
Email: enquiry@yorkemc.com

A list of York EMC Services' representatives around the world can be found on our website:

<http://www.yorkemc.com>

Please see your nearest agent for details of their opening times.

Quotations

All quotations issued directly by York EMC Services are in GBP. Unless otherwise stated, our quotations are valid for 30 days. VAT will be charged at the standard rate applicable at the time of invoice.

Orders

Orders are accepted with an accompanying Purchase Order number.

Stocks

Stock availability and delivery times may fluctuate with market conditions, production capacity and any additional test results requirements. Please check with our sales team for an update.

Delivery

Standard delivery is 28 days from receipt of order unless otherwise specified. Orders are normally shipped by courier at the rate stated on the quotation. Alternatively the customer may arrange for their own pick-up service.

Payment Methods

We can accept payment in GBP, US dollars or Euros by bank transfer, UK drawn cheque or credit card. New customers may be asked for payment in advance. Existing customers with a good credit history are eligible for credit terms.

Warranty

All products are supplied with a one year return-to-base warranty as standard, unless otherwise stated. Extended warranty terms may be arranged, please ask our sales team for details.

Terms and Conditions

All our orders are subject to our terms and conditions. Please ask our sales team for full details.

Technical Data















We have endeavoured to ensure the information in this brochure is accurate at the time of publication. However, in the interests of product advancement, we reserve the right to improve, refine and otherwise modify specifications without notice E&OE.

Online Brochure

Our website is the definitive source for information regarding new products, updated specifications, application notes and more. Please visit <http://www.yorkemc.com> for information regarding our Test Instrumentation, as well as for details of our accredited EMC Test laboratories, Consultancy and Research, Training Courses and Workshops.

Battery Powered Reference Signal Sources

Other

| | CNE V Noise source | CNE V+ Noise source | CNE VI Noise source | YRS01 Combined noise and comb source | YRS02 Combined noise and comb source | YRS03 Combined noise and comb source | CGE01C Conducted comb source | CGE01R Radiating comb source | CGE02C Conducted comb source | CGE02R Radiating comb source | CGE03C Conducted comb source | ARA01 Active receive antenna | HFG01 Harmonic and flicker generator | HFG02 Harmonic and flicker generator | CCC01 Cable coupling clamp |
|--|---|---|---|---|--|---|---|---|---|---|---|---|---|---|---|
| What |  |  |  |  |  |  |  |  |  |  |  |  |  |  |  |
| Type | Reference Source | Reference Source | Reference Source | Reference Source | Reference Source | Reference Source | Reference Source | Radiating Reference Source | Reference Source | Radiating Reference Source | Reference Source | Antenna | Reference Generator | Reference Generator | Cable Test Jig |
| Signal Type | Continuous Noise | Continuous Noise | Continuous Noise | Noise & Comb output | Noise & Comb output | Noise & Comb output | Comb output | Comb output | Comb output | Comb output | Comb output | Received E field | Mains disturbance | Mains disturbance | Coupled signal |
| Frequency Range (conducted) | 9 kHz to 1 GHz | 9 kHz to 3.5 GHz | 30 Hz to 6 GHz | 9 kHz to 1 GHz | 9 kHz to 1 GHz | 30 MHz to 6 GHz | 50 MHz to 18 GHz | n/a | 250 MHz to 26 GHz | n/a | 0.9 GHz to 40 GHz | n/a | 50 Hz to 2 kHz | 40 th Harmonic | n/a |
| Frequency Range (radiated) | (see antenna) | (see antenna) | (see antenna) | (see antenna) | (see antenna) | (see antenna) | (see antenna) | 1 GHz to 18 GHz | (see antenna) | 1 GHz to 26 GHz | (see antenna) | 30 MHz to 1 GHz | n/a | n/a | n/a |
| Specifications | | | | | | | | | | | | | | | |
| Output Connector | BNC | N-type | BNC & N-type | N-type | N-type | N-type | SMA | n/a | SMA | n/a | SMA | BNC | UK 3-pin mains plug | UK 3-pin mains plug | N-type |
| Temperature Stability (dB) <small>(Typical: 15 °C to 30 °C)</small> | < ± 1 | < ± 1 | < ± 1 | < ± 1 | < ± 1 | < ± 1 | < ± 2 | < ± 2 | < ± 1 | < ± 1 | < ± 2 | < 1 | n/a | n/a | n/a |
| Time Stability (dB) <small>(Typical over 12 months)</small> | < 1 | < 1 | < 1 | < 1 | < 1 | < 1 | < 1 | < 1 | < 1 | < 1 | < 1 | < 1 | n/a | n/a | n/a |
| Auto Power Off | No | No | Yes | Yes | Yes | Yes | Yes | Yes | Yes | Yes | Yes | No | n/a | n/a | n/a |
| Dimensions (mm) <small>(without battery packs, antennas etc.)</small> | 120 x 120 x 60 | 120 x 120 x 60 | 120 x 120 x 79 | 56 x 76 dia. | 120 x 120 x 79 | 120 x 120 x 79 | 28 x 76 dia. | 46 x 76 dia. | 28 x 76 dia. | 46 x 76 dia. | 56 x 76 dia. | 168 x 34 x 34 | 330 x 320 x 170 | 330 x 320 x 170 | |
| Weight (kg) | 0.53 | 0.53 | 1 | 0.6 | 1 | 1 | 0.55 | 0.55 | 0.55 | 0.55 | 0.75 | 0.39 | 6.5 | 8 | 0 |
| Power Supply | PP3 battery | PP3 battery | 4 x AA cells | BP01 battery pack 5 V (mini-USB) | 4 x AA cells | 4 x AA cells | BP01 battery pack | BP01 battery pack | BP01 battery pack | BP01 battery pack | BP01 battery pack | PP3 battery | 230 Vac, 50 Hz | 100 - 240 Vac, 50 - 60 Hz | n/a |
| Operating Time (hours) <small>(Typical, fully charged where applicable)</small> | 3 | 3 | 6.5 to 14 | 7.5 to 8.5 | 7.5 to 8 | 6.5 to 14 | 6.5 | 6.5 | 6.5 | 6.5 | 4 | 6.5 | n/a | n/a | n/a |
| Indicators | Green: Active Red: Low Battery | Green: Active Red: Low Battery | Green: Active Red: Low Battery | Green: Active Red: Low Battery | Green: Active Red: Low Battery | Green: Active Red: Low Battery | Green: 80 MHz steps Red: 50/100 MHz steps | Green: 80 MHz steps Red: 50/100 MHz steps | Green: 250 MHz steps Red: 256 MHz steps Flashing: Supply error | Green: 250 MHz steps Red: 256 MHz steps Flashing: Supply error | Green: 1 GHz steps Red: 900 MHz steps Flashing: Supply error | Green: Active Red: Low Battery | Thermal shutdown | Supply, Test Supply, Alarms, Running | n/a |
| Applications | | | | | | | | | | | | | | | |
| Pre-test checks | • | • | • | • | • | • | • | • | • | • | • | • | • | • | • |
| Long-term performance monitoring | • | • | • | • | • | • | • | • | • | • | • | | • | • | |
| Measurement environment comparison | • | • | • | • | • | • | • | • | • | • | • | • | | | |
| OATS, FAR, SAC characterisation | • | • | • | • | • | • | • | • | • | • | • | • | | | |
| Reverberation chamber characterisation | | | | | | | • | • | • | • | • | | | | |
| Filter performance analysis | • | • | • | • | • | • | • | • | • | • | • | | | | |
| Cable/connector loss analysis | • | • | • | • | • | • | • | • | • | • | • | | | | |
| Shielding effectiveness measurements | | | | • | • | • | • | • | • | • | • | | | | • |
| Confined space/portable measurements | | | | | | | | | | | | • | | | |
| Low cost, compact, wideband antenna | | | | | | | | | | | | • | | | |
| Inter-laboratory test program | • | • | • | • | • | • | • | • | • | • | • | | • | • | |
| Proficiency test program | • | • | • | • | • | • | • | • | • | • | • | | • | • | |
| Kits | | | | | | | | | | | | | | | |
| Recommended Kit | CNEVKIT02 | CNEVKIT04 | CNEVIKIT02 | YRS01KIT02 | YRS02KIT02 | YRS03KIT02 | CGE01KIT03 | CGE01KIT02 | CGE02KIT03 | CGE02KIT02 | CGE03KIT02 | ARA01KIT01 | HFG01KIT01 | HFG02KIT01 | CCC01KIT01 |

Overview of Accessories for YES Test Instrumentation

Battery Powered Reference Signal Sources

Other

Key:
 KIT0x – Kit reference containing this accessory.
 Extra – Not a standard kit part, purchased separately.
 X – Unavailable.
 R/O – Recalibration only.

Antennas & Kit References

| | CNE V Noise source | CNE V+ Noise source | CNE VI Noise source | YRS01 Combined noise & comb source | YRS02 Combined noise & comb source | YRS03 Combined noise & comb source | CGE01C Conducted comb source | CGE01R Radiating comb source | CGE02C Conducted comb source | CGE02R Radiating comb source | CGE03C Conducted comb source | ARA01 Active receive antenna | HFG01 Harmonic and flicker generator | HFG02 Harmonic and flicker generator | CCC01 Cable coupling clamp |
|-------|---|------------------------|------------------------|---------------------------------------|---------------------------------------|---------------------------------------|---------------------------------|---------------------------------|---------------------------------|---------------------------------|---------------------------------|---------------------------------|---|---|-------------------------------|
| | 9 kHz to 1 GHz | 9 kHz to 3.5 GHz | 30 Hz to 6 GHz | 9 kHz to 1 GHz | 9 kHz to 1 GHz | 30 MHz to 6 GHz | 50 MHz to 18 GHz | 1 GHz to 18 GHz | 250 MHz to 26 GHz | 1 GHz to 26 GHz | 0.9 GHz to 40 GHz | 30 MHz to 1 GHz | 50 Hz to 2 kHz | 40 th Harmonic | n/a |
| | CNEKIT01 CNEKIT02 | CNEKIT03 CNEKIT04 | CNEKIT01 CNEKIT02 | YRS01KIT01 YRS01KIT02 | YRS02KIT01 YRS02KIT02 YRS Combo | YRS03KIT01 YRS03KIT02 YRS combo | CGE01KIT01 CGE01KIT03 | CGE01KIT02 | CGE02KIT01 CGE02KIT03 | CGE02KIT02 | CGE02KIT02 | ARA01KIT01 | HFG01KIT01 | HFG02KIT01 | CCC01KIT01 |
| MCN02 | 75 mm dia. monocone (1 to 26 GHz optimum) | X | X | X | X | X | KIT03 & KIT06 | X | KIT03 | X | KIT02 | X | X | X | X |
| MCN03 | 120 mm dia. monocone (1 to 6 GHz optimum) | X | KIT04 | KIT02 | X | All kits | X | X | X | X | X | X | X | X | X |
| MON02 | Telescopic rod | Extra | Extra | Extra | Extra | Extra | X | X | X | X | X | X | X | X | X |
| MON03 | 270 mm monopole (200 MHz to 1 GHz optimum) | Extra | Extra | All kits | All kits | All kits | KIT02 / Combo | Extra | X | X | X | X | X | X | X |
| TLM01 | 100 mm top-loaded monopole (200 MHz to 1 GHz optimum) | All kits | All kits | Extra | Extra | Extra | X | X | X | X | X | X | X | X | X |
| TLM02 | 270 mm monopole (30 MHz to 300 MHz optimum) | KIT02 | KIT04 | KIT02 | KIT02 / Combo | KIT02 / Combo | X | X | X | X | X | X | X | X | X |
| DAE01 | Pair of 100 mm top-loaded monopole (200 MHz to 1 GHz optimum) | X | X | X | X | X | X | X | X | X | X | All kits | X | X | X |
| DAE02 | Pair of 270 mm monopole (30 MHz to 300 MHz optimum) | X | X | X | X | X | X | X | X | X | X | Extra | X | X | X |

Coupling Networks

| | | | | | | | | | | | | | | | |
|-------|--|-------|-------|----------|-------|---------------|---|---|---|---|---|---|---|---|---|
| LSA03 | LISN adapter with IEC-style connector | KIT02 | KIT04 | All kits | KIT02 | KIT02 / Combo | X | X | X | X | X | X | X | X | X |
| NIA01 | ISN adapter with RJ11- and RJ45-style connectors | Extra | Extra | Extra | Extra | Extra | X | X | X | X | X | X | X | X | X |

Batteries

| | | | | | | | | | | | | | | | |
|------|--|----------|----------|----------|----------|----------|----------|----------|----------|----------|----------|----------|---|---|---|
| BP01 | 5V 2AHr NiMH rechargeable battery pack and charger | X | X | X | All kits | X | X | All kits | All kits | All kits | All kits | X | X | X | X |
| AA | Alkaline or NiMH cell | X | X | All kits | X | All kits | All kits | X | X | X | X | X | X | X | X |
| PP3 | Alkaline or NiMH battery | All kits | All kits | X | X | X | X | X | X | X | X | All kits | X | X | X |

Other

| | | | | | | | | | | | | | | | |
|------------------|--|----------|----------|----------|----------|----------|----------|----------|----------|----------|----------|----------|----------|----------|----------|
| TRA01 | Tripod adapter for ARA01 | X | X | X | X | X | X | X | X | X | X | Extra | X | X | X |
| CMF01 | Kit of user-machinable fittings blank fittings for custom cable apertures (single cable per kit) | X | X | X | X | X | X | X | X | X | X | X | X | X | Extra |
| Case | (Hard plastic case - various) | All kits | All kits | All kits | All kits | All kits | All kits | All kits | All kits | All kits | All kits | All kits | X | X | All kits |
| Manual | Operation manual supplied as PDF on CDROM | All kits | All kits | All kits | All kits | All kits | All kits | All kits | All kits | All kits | All kits | All kits | All kits | All kits | All kits |
| Test Certificate | Basic output measurement certificate. Supplied as hardcopy, PDF, XLSX and CSV files on CDROM | All kits | All kits | All kits | All kits | All kits | All kits | All kits | All kits | All kits | All kits | All kits | All kits | All kits | X |

Conducted (output power)

| | | | | | | | | | | | | | | | |
|-------|--|----------|----------|----------|----------|----------|----------|---|----------|---|----------|---|---|---|---|
| CAL01 | 9 kHz to 5 GHz using spectrum analyser | X | All kits | X | X | X | X | X | X | X | X | X | X | X | X |
| CAL03 | 9 kHz to 1 GHz using spectrum analyser | All kits | X | X | X | X | X | X | X | X | X | X | X | X | X |
| CAL13 | 0 GHz to 18 GHz using spectrum analyser | X | X | X | X | X | All kits | X | X | X | X | X | X | X | X |
| CAL14 | 0 GHz to 26 GHz using spectrum analyser | X | X | X | X | X | X | X | All kits | X | X | X | X | X | X |
| CAL15 | 0 GHz to 40 GHz using spectrum analyser | X | X | X | X | X | X | X | X | X | All kits | X | X | X | X |
| CAL16 | 9 kHz to 1 GHz using spectrum analyser, all modes | X | X | X | All kits | All kits | X | X | X | X | X | X | X | X | X |
| CAL19 | 30 MHz to 6 GHz using spectrum analyser, all modes | X | X | X | X | X | All kits | X | X | X | X | X | X | X | X |
| CAL20 | 0 GHz to 6 GHz using spectrum analyser, all modes | X | X | All kits | X | X | X | X | X | X | X | X | X | X | X |

Radiated (field strength)

| | | | | | | | | | | | | | | | |
|-------|---|-------|-------|-------|-------|-------|----------------------|----------|----------------------|----------|----------------------|---|---|---|---|
| CAL02 | 30 MHz to 1 GHz on an OATS, 3 m or 10 m test distance | Extra | Extra | Extra | X | X | X | X | X | X | X | X | X | X | X |
| CAL04 | 30 MHz to 1 GHz on an OATS, 3 m and 10 m test distance | Extra | Extra | Extra | X | X | X | X | X | X | X | X | X | X | X |
| CAL06 | 30 MHz to 1 GHz in a FAR, 3 m test distance | Extra | Extra | Extra | X | X | X | X | X | X | X | X | X | X | X |
| CAL07 | 1 GHz to 7 GHz in a FAR, 3 m test distance | X | X | Extra | X | X | X | X | X | X | X | X | X | X | X |
| CAL09 | 1 GHz to 18 GHz in a FAR, 3 m test distance | X | X | X | X | X | Extra for KIT03 only | All kits | X | X | X | X | X | X | X |
| CAL10 | 1 GHz to 26 GHz in a FAR, 3 m test distance | X | X | X | X | X | X | X | Extra for KIT03 only | All kits | Extra for KIT02 only | X | X | X | X |
| CAL17 | 30 MHz to 1 GHz on an OATS, 3 m or 10 m test distance, all modes | X | X | X | Extra | Extra | Extra | X | X | X | X | X | X | X | X |
| CAL18 | 30 MHz to 1 GHz in a FAR, 3 m test distance, all modes | X | X | X | Extra | Extra | Extra | X | X | X | X | X | X | X | X |
| CAL21 | 1 GHz to 6 GHz in a FAR, 3 m test distance, noise, 20 MHz and 40 MHz comb modes | X | X | X | X | X | Extra | X | X | X | X | X | X | X | X |

Other

| | | | | | | | | | | | | | | | |
|-------|--|---|---|---|---|---|---|---|---|---|---|----------|----------|----------|---|
| CAL08 | Antenna factors, 30 MHz to 1 GHz | X | X | X | X | X | X | X | X | X | X | All kits | X | X | X |
| CAL12 | Measurement of harmonics and flicker in relevant modes | X | X | X | X | X | X | X | X | X | X | X | All kits | X | X |
| CAL22 | Measurement of harmonics and flicker in relevant modes | X | X | X | X | X | X | X | X | X | X | X | X | All kits | X |



For further information please contact
one of our offices, or visit us online

Email: enquiry@yorkemc.com
www.yorkemc.com

Your Smart Route to Compliance

- Compliance Testing
- Consultancy Services
- Training
- Test Instrumentation



Market Square
University of York
Heslington, York
YO10 5DD

Tel: +44 (0) 1904 324440
Fax: +44 (0) 1904 324434

Three Lane Ends
Business Centre
Methley Road, Castleford
WF10 1PN

Tel: +44 (0) 1977 731173
Fax: +44 (0) 1977 603181

46 Waverley Road
Beeches Industrial Estate
Yate
BS37 5QT

Tel: +44 (0) 1454 326998
Fax: +44 (0) 1454 326930

Unit 1
Grangemouth Technology Park
Earls Road, Grangemouth
FK3 8UZ

Tel: +44 (0) 1324 469000
Fax: +44 (0) 1904 324434