

Model 5400 Series

**Gigahertz Transverse
Electromagnetic
(GTEM![™]) Cell**

Operation Manual



 **ETS·LINDGREN**[™]
An ESCO Technologies Company

ETS-Lindgren L.P. reserves the right to make changes to any products herein to improve functioning or design. Although the information in this document has been carefully reviewed and is believed to be reliable, ETS-Lindgren does not assume any liability arising out of the application or use of any product or circuit described herein; nor does it convey any license under its patent rights nor the rights of others. All trademarks are the property of their respective owners.

©Copyright 1998–2008 by ETS-Lindgren L.P. All Rights Reserved. No part of this document may be copied by any means without written permission from ETS-Lindgren L.P.

Trademarks used in this document: The *ETS-Lindgren* logo and *GTEM!* are trademarks of ETS-Lindgren L.P.; *MS-DOS* is a registered trademark of Microsoft Corporation in the United States and/or other countries; *WD-40* is a registered trademark of WD-40 Company; *LPS 2* is a registered trademark of LPS Laboratories.

Revision Record | MANUAL GTEM 5400 SERIES | Part #399250, Rev. F

Revision	Description	Date
A	Initial Release	April, 1998
B	Updates/edits	December, 1999
C	Updates/edits	October, 2005
D	Added Section 6: <i>Ortho-Axis Positioner – Pneumatic (Optional)</i>	March, 2007
E	Updated Section 6: <i>Ortho-Axis Positioner – Pneumatic (Optional)</i>	April, 2007
F	Added finger stock gasket content; rebrand	August, 2008

Table of Contents

- Notes, Cautions, and Warningsix**
- 1.0 Introduction 11**
 - Standard Configuration..... 11
 - Blank Feed-Through Panel..... 11
 - Internal EUT Manipulator..... 11
 - Custom Signal Filters 12
 - Custom Power Filters 12
 - Custom Internal Illumination..... 12
 - Optional Items..... 13
 - High Voltage Pulse Feed..... 13
 - Basic Theory of RF Operation 14
 - ETS-Lindgren Product Information Bulletin 15
- 2.0 Maintenance 17**
 - Performance Monitoring 17
 - Owner/Operator Maintenance Items 17
 - Finger Stock Gasket..... 17
 - Air Vents 21
 - Floor Connector Panels..... 21
 - Connectors 22
 - Absorber Tips 22
 - Shielded Viewing Windows (Optional) 23
 - GTEM! Cleaning 23
 - Load Boards 24
 - Other Maintenance 24
 - In Case of Damage..... 24

3.0 Specifications.....	25
Physical Specifications	25
Electrical Specifications.....	26
4.0 GTEM! Assembly	27
Model 5405 Assembly Drawing with Outer Dimensions	28
Model 5407 Assembly Drawing with Outer Dimensions	29
Model 5411 Assembly Drawing with Outer Dimensions	30
5.0 Measured GTEM! Performance.....	31
GTEM! Performance Qualification – VSWR.....	31
Typical VSWR Measurement – Model 5407	31
GTEM! Electromagnetic Field Response	32
E-Field Frequency Response.....	32
Typical E-Field Frequency Response – Model 5407	32
Electric Field Uniformity.....	33
Typical Electric Field Uniformity – Model 5407	33
Time Domain Reflectometer.....	34
GTEM! Shielding Effectiveness.....	34
GTEM! Emissions Testing Characterization.....	34
6.0 GTEM! Use.....	35
Radiated Immunity Testing.....	35
Substitution Method.....	35
Direct Method	35
Estimation of GTEM! RF Input Power Required for Given Field Strength	36
Typical 10 V/m Power Required – Model 5400 Series.....	37
Typical Automated Radiated Immunity Test Setup	38
Radiated Emissions Testing – General.....	39
Radiated Emissions Measurements – Hardware Requirement	40



EUT Orientation for Testing.....	40
Measurement Procedure	41
Typical EUT System Installed in Large GTEM!.....	43
Typical EUT System Installed in Large GTEM! (90° Rotation).....	44
Typical EUT System Installed in Large GTEM! (Additional 90° Rotation).....	45
Software Computations	46
7.0 Ortho-Axis Positioner – Pneumatic (Optional).....	47
Operation.....	47
Functional Schematic	49
Ortho-Axis Positioner for Model 5405	50
Ortho-Axis Positioner for Model 5407	54
Ortho-Axis Positioner for Model 5411	55
8.0 GTEM! Manual EUT Manipulator (Optional).....	57
EUT Manipulator Platform Apparatus.....	57
9.0 Manual EUT Manipulator Operation Theory	59
Measurements in a GTEM!.....	59
Far-Field Measurements	59
Near-Field Measurements	59
Manual EUT Manipulator – Model 5407.....	60
Special Measurements.....	61
Immunity Measurements	61
Installing the Manipulator and EUT	61
Naming the EUT Faces	62
EUT as a Cube on Cartesian Axes Showing Names of Faces	62
EUT Positions.....	63
Sets of Positions Needed	63
Manual EUT Manipulator Positions for Three-Position Emissions Test – Model 5400 Series.....	64

Appendix A: Warranty	67
Appendix B: Emission Measurements in TEM Cells and TEM Lines	69
Multipole Model	69
Two-Port TEM Cell or TEM Line Correlation Routine	69
One-Port TEM Cell Correlation Routine	69
TEM Cell Voltage Measurements: Three Positions	70
Appendix C: Radiated Emissions Test Performance of GTEM!.....	71
Abstract.....	71
Introduction.....	71
Goals of Testing and Analysis.....	73
Design of Testing.....	73
General.....	73
Reference Dipole Antenna Testing	75
Personal Computer Testing.....	76
Design of Data Analysis	80
Direct Comparisons	80
Statistical Comparisons.....	80
Test Series 1 – Dipole Testing	81
Personal Computer Testing.....	85
Discussion of Test Results	86
Results of Comparative Analysis.....	86
Results of Statistical Analysis.....	88
Summary of Statistical Findings	88
Measurement Error, Precision, and Repeatability.....	89
Conclusions	89
Test Procedure Specific Conclusions.....	89
More General Conclusions.....	90

Acknowledgements	90
References	91
Characteristic and Wave Impedances of a GTEM!	92
Termination Characteristics.....	93
Appendix D: Related Downloads.....	95

This page intentionally left blank.

Notes, Cautions, and Warnings

	<p>Note: Denotes helpful information intended to provide tips for better use of the product.</p>
	<p>Caution: Denotes a hazard. Failure to follow instructions could result in minor personal injury and/or property damage. Included text gives proper procedures.</p>
	<p>Warning: Denotes a hazard. Failure to follow instructions could result in SEVERE personal injury and/or property damage. Included text gives proper procedures.</p>



See the ETS-Lindgren *Product Information Bulletin* for safety, regulatory, and other product marking information.

This page intentionally left blank.

1.0 Introduction

The **ETS-Lindgren Gigahertz Transverse Electromagnetic (GTEM!™) Cell** is a precision electromagnetic compatibility (EMC) test instrument primarily intended for use as an EMC radiated immunity and radiated emissions test facility. It is intended for installation in a corporate, laboratory, or industrial environment, where its unique characteristics allow for the performance of fast and efficient EMC radiated tests at a convenient location, without interference from the ambient electromagnetic environment.

The GTEM! is a pyramidal tapered, dual-terminated section of 50-ohm transmission line. The cell is flared to create a test volume within which the Equipment Under Test (EUT) is placed. At the input, a normal 50-ohm coaxial line is physically transformed to a rectangular cross section with an aspect ratio of 3:2 horizontal to vertical. The center conductor, known as the septum, is a flat, wide conductor which, when driven by a signal generator, produces a reasonably sized region of a nominally uniform electric field distribution beneath it. This region of nominally uniform field is the test volume for radiated immunity (susceptibility) testing. By the theory of reciprocity, radiated emissions testing is also conducted in the test volume. To increase the usable test volume, the septum is located well above the horizontal centerline of the cross section, while maintaining constant characteristic impedance and uniform field distribution. The septum is terminated in a resistive array having a total value of 50 ohms for matching the impedance of the source. Test volume fields, either applied to an immunity test item or produced by the EUT during emissions testing, are terminated in RF absorber. The shape of the test volume is a tapered wedge. The fields generated by application of an RF voltage to the input of the GTEM! propagate with a spherical wave front from the apex of the GTEM! to the termination.

Standard Configuration

BLANK FEED-THROUGH PANEL

A blank, 304-mm square, removable panel can be installed in the GTEM! wall to accommodate additional cable entries. Separate blank removable panels are available and are interchangeable.

INTERNAL EUT MANIPULATOR

A multi-position EUT manipulator is available for the GTEM! to assist in locating the EUT for radiated emissions testing.

CUSTOM SIGNAL FILTERS

To meet unique signal input and output requirements, a custom-designed filter is available mounted to penetration panels.

CUSTOM POWER FILTERS

For additional EUT power input requirements, a number of single and three-phase input power filters are available to provide almost any input power requirement to EUT in a GTEM!. These power inputs are independently-switched; they are not controlled through the main power switch on the power distribution panels.

CUSTOM INTERNAL ILLUMINATION

A low-voltage light source is available for installation in the Model 5405, Model 5407, and Model 5411. A power filter is also supplied as part of the light assembly.

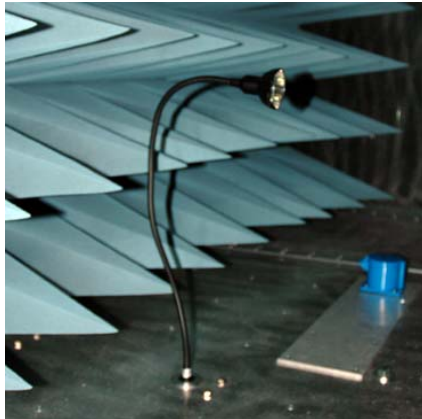

Optional Items

Every application for a GTEM! in EMC testing will be unique or may have unique requirements. If a modification to the GTEM! will accelerate test performance, contact ETS-Lindgren. Most of the standard items described in the previous section are field-installable and can be retrofitted after delivery.

HIGH VOLTAGE PULSE FEED

The GTEM! is typically used for CW emission and immunity tests. It can also be used for high voltage pulse radiated immunity measurements. The High Voltage Pulse Feed (HVPF) is a replacement feed section supplied for use with Model 5405 and larger. The HVPF is available as a bolt-on (standard) or clamp-on section. In both cases, the septum is fitted with an edge connector, which makes removal of the complete CW section possible without disassembly.

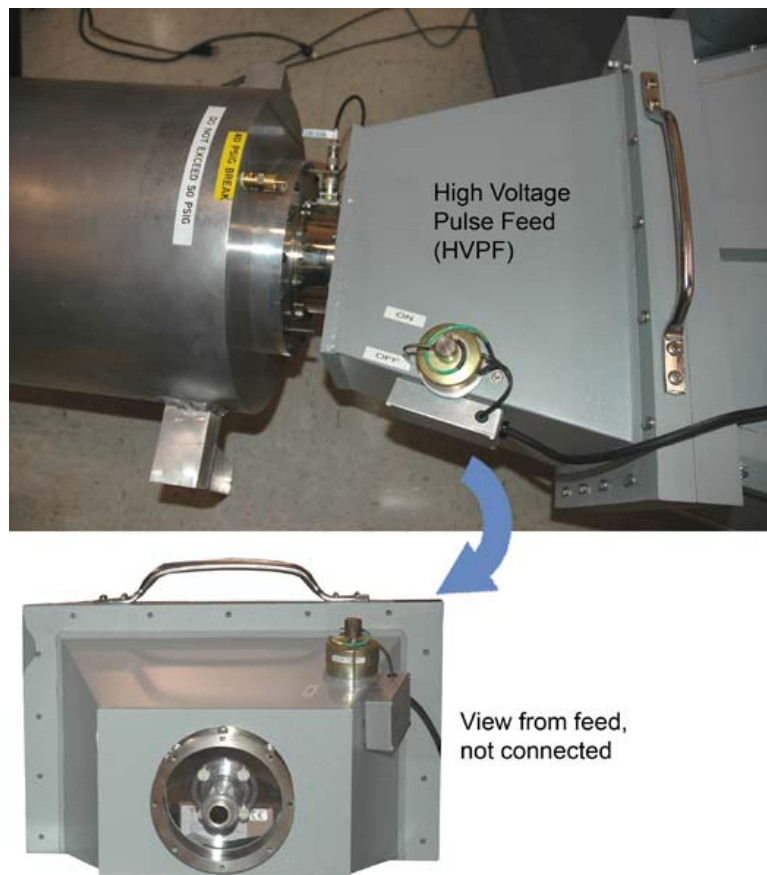

The standard 7/16 to N adapter fitted to the front of the CW section is designed for CW RF use and can be used for RF voltages up to 800 volts. The dielectric withstand voltage for the connector is 2.3K volts. The voltage at the connector of this feed section should not exceed 2.3K volts since it will be impossible to predict when breakdown will begin to occur. The potential for breakdown increases as a function of the humidity level, pulse width, and voltage magnitude. While it is possible to use the CW section for very short duration pulses greater than 2.3K volts, it is recommended that for pulse measurements where the peak voltage of the pulse is expected to exceed 3K volts regularly, the HVPF should be used.

Basic Theory of RF Operation

The GTEM! is essentially a section of asymmetric rectangular transmission line with a unique flared geometry and a hybrid termination. There is a 50-ohm resistor termination for currents flowing on the septum, and an RF foam absorber termination for electromagnetic fields generated in the GTEM! that propagate towards the back wall. An RF signal applied to the center conductor will result in the generation of a predominantly vertical \vec{E} field above and below the septum with radiating components toward the outer conductor, as is the case in a coaxial transmission line.

Ideally, the center one-third of the volume below the septum, both vertically and horizontally, is of sufficient uniform distribution to allow the use of the GTEM! for immunity testing. In actuality, a test volume producing accurate results for radiated emissions testing may be as large as two-thirds of the vertical and horizontal dimensions (depending on the type of equipment under test). Under ideal circumstances, the magnitude of the field changes gradually from a maximum at the septum, to zero at the outer cell wall (conductor). The uniform area, therefore, lies in the region where this transition in field is within the limits of the specified measurement uncertainty.

The frequency of the transverse electromagnetic mode (TEM) mode supported in the cell is a function of the distance between the center conductor (septum) and the outer conductor. Above frequencies where this distance is greater than a wavelength, higher order modes may also be supported.

The presence of the Equipment Under Test (EUT) may also affect the performance of the GTEM! since to the advancing wave, it would appear as a change in the impedance of the incident field.

The GTEM! provides a matched termination to input signals; there are no severe VSWR problems as usually experienced with low-frequency biconical class antennas. It is relatively easy to produce low frequency intense electromagnetic fields with the GTEM!. The capability of a GTEM! to operate without size or scaling problems well into the GHz frequency range allows the testing of items without the need for the antenna changes associated with other test sites.

ETS-Lindgren Product Information Bulletin

See the ETS-Lindgren *Product Information Bulletin* included with your shipment for the following:

- Warranty information
- Safety, regulatory, and other product marking information
- Steps to receive your shipment
- Steps to return a component for service
- ETS Lindgren calibration service
- ETS Lindgren contact information

This page intentionally left blank.

2.0 Maintenance

WARNING

Before performing any maintenance, follow the safety information in the ETS-Lindgren *Product Information Bulletin* included with your shipment.

Periodic maintenance will ensure the continued performance of the Gigahertz Transverse Electromagnetic (GTEM!TM) Cell. Several areas must be considered, as described in the following sections.

Performance Monitoring

On-site VSWR measurements are normally performed at the conclusion of installation procedures for the GTEM!. They are also performed at the factory for all factory-assembled GTEM! cells. If the GTEM! is to be installed by an ETS-Lindgren representative, then the on-site VSWR measurement is the responsibility of the representative. Determination of continued performance to specified parameters may be ensured by periodic re-measurement of the VSWR. This could detect changes in performance parameters that would signal unacceptable performance. The VSWR measurement should be performed on a schedule as recommended by the customer's Quality Engineering. The default time period between such evaluations (this is not a calibration) is six months.

Owner/Operator Maintenance Items

FINGER STOCK GASKET

A large amount of finger stock is used in the construction of the GTEM!. Some of this finger stock is accessible in the normal course of GTEM! operation. Periodic visual inspections must be made to determine if there is need to clean the finger stock, or to replace it if damaged. Replacement finger stock for the doors is available from the factory; replacement finger stock for the connector panels and the load board access panels is also available. See the steps beginning on page 18 to replace finger stock gasket.

To clean finger stock, use an aerosol lubricant to loosen the debris, and then low-pressure air or another aerosol to remove the excess lubricant. Alternatively, a soft rag may be used to remove dirt and excess liquid from the finger stock. For more information on cleaning and troubleshooting problems with finger stock gasket, see page 19.

Replacing Finger Stock Gasket

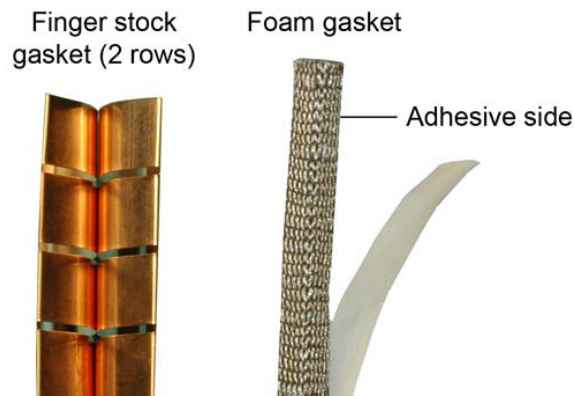

A 1-mm (0.04-in) groove in the GTEM! door retains the finger stock gasket. The gasket may be easily removed after one row of fingers clears the groove. Following are the steps to replace finger stock gasket:

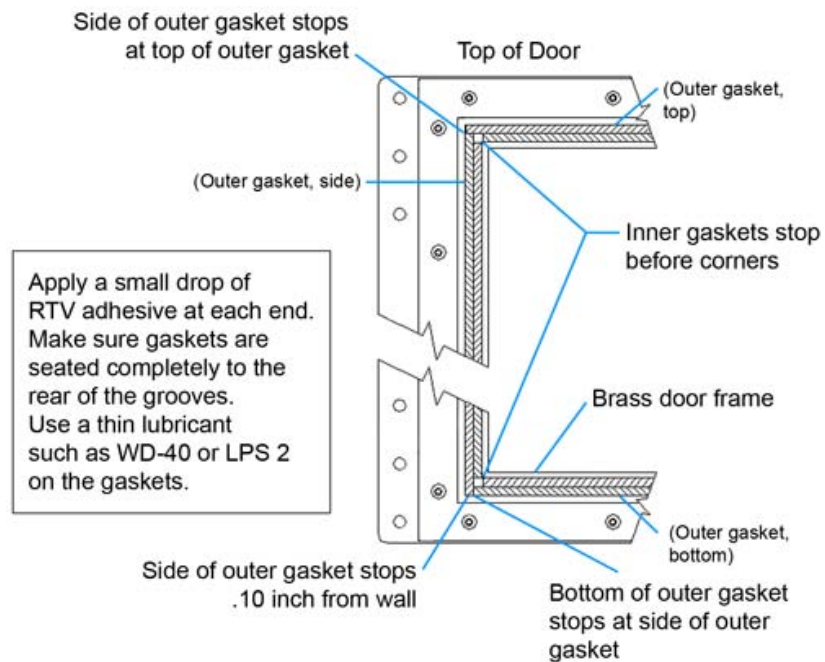

1. From one end of the finger stock gasket, grab a finger with needle-nose pliers and gently pull it out and over the groove. Hold the end out.
2. While holding the end out, use a screwdriver to pry the next few fingers away from the groove. Continue to hold the end out.
3. Slide a wide, thin blade down the entire strip to move all the fingers out and over the groove.
4. Remove both rows of finger stock gasket by pulling them out.

5. Inspect the foam gasket that is now exposed, and make sure it is recessed in the groove. If it is not recessed, replace it with new foam gasket part # 890645. The new foam gasket is 5 mm (0.2 in) square; the old foam gasket was 6.3 mm (0.25 in) square.

To remove the foam gasket—Grab one end with needle-nose pliers and gently pull the gasket out from the groove. There is adhesive on the side of the gasket facing the groove.

To install new foam gasket—Place the gasket with the adhesive side facing the groove. Do not twist the gasket, and do not place the gasket to the side of the groove, where it will interfere with the finger stock gasket.

6. Install the finger stock gasket. Make sure to install it properly at corners of the door.
7. To trim the length of the finger stock gasket, gently bend the gasket with your fingers until it breaks.

Troubleshooting Finger Stock Gasket Problems



Apply lubricant as regular maintenance—Finger stock gasket requires a thin coat of spray-on lubricant, such as WD-40® or LPS 2®. After spraying the lubricant onto the gasket, wipe off excess from the brass frame and door paint.

Apply lubricant once a month or more often, as necessary.

Symptom	Cause / Information	Action
Excessive compression of gasket fingers	<p>If you have a door with a male brass frame, the frame must be replaced; this requires the removal of the door from the hinges.</p> <p>This does not apply to a GTEM! with a female frame.</p>	Contact the ETS-Lindgren Sales Department with your GTEM! serial number to obtain a replacement frame.



Some older doors have a male brass frame with a blade thickness of 4.75 mm (0.19 in). To reduce stress on the gasket fingers, the blade thickness was changed to 3 mm (0.12 in) on newer doors.

Symptom	Cause / Information	Action
Poor alignment of gasket fingers	<p>The doors should be centered within 0.75 mm (0.03 in).</p> <p>The ideal dimension between the male frame and female frame is 26.9 mm (1.06 in).</p> <p>It should not vary more than 1.5 mm (0.6 in) around the door.</p>	<p>When replacing finger stock gasket, make sure to align the fingers as indicated.</p>
Improper seating of foam gasket	<p>The finger stock gasket must be seated completely to the rear or it will break when closing the door. If the foam gasket is poorly assembled and improperly seated in the groove, it can interfere with the seating of the finger stock gasket.</p> <p>The foam gasket for newer doors is 5-mm (0.2-in) square; the foam gasket for older doors was 6.3-mm (0.25-in) square.</p>	<p>If the foam gasket is not seated properly, replace it.</p>
Shifting of finger stock gasket	<p>The inner top and bottom rows may shift over time, breaking at the corners. The vertical row and horizontal inner row should never extend past any corner.</p> <p>Newer doors have a small amount of RTV adhesive applied at each end of the gasket to hold it in place.</p>	<p>When replacing finger stock gasket, apply RTV adhesive to each end of the gasket.</p>
Incorrect assembly at corners	<p>The top outer row must extend to both corners. If necessary, break the finger stock gasket to leave a gap in the center of the gasket so that it will extend to the corners.</p> <p>The outer vertical rows should extend from the bottom corners to meet and support the top row in the upper corners.</p> <p>The outer bottom row should extend to meet the vertical rows in bottom corner.</p>	<p>When replacing finger stock gasket, make sure to assemble the gasket at corners as indicated.</p>

AIR VENTS

The air vents on the Model 5400 Series must be checked to make sure that free airflow exists to ensure optimum cooling. A small soft brush or low-pressure air may be used to clean the honeycomb.

FLOOR CONNECTOR PANELS

The connector feed-through panels in the floor of the GTEM! will attract small particles of dirt or other debris. Inspection of their continuity on a periodic basis is necessary to ensure continued shielding. To inspect for an accumulation of dirt, the panels should be removed and the opening and the flange should be inspected and any accumulated dirt or debris removed. The finger stock must be inspected at this time, and cleaned or replaced if required.

See page 17 for information on replacing and cleaning finger stock gasket.

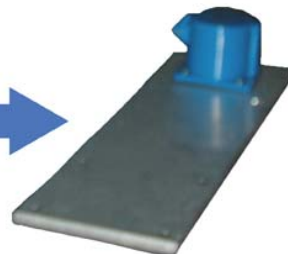
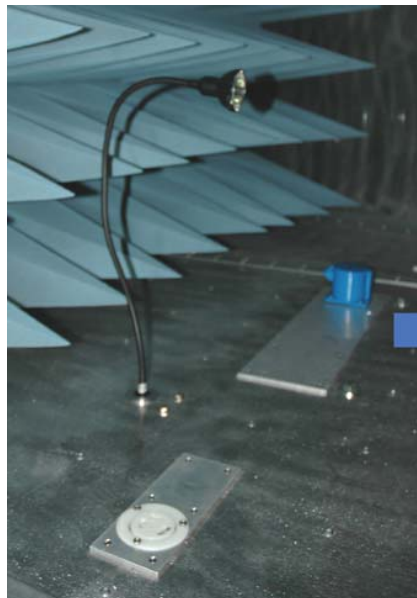

CONNECTORS

The RF and other connectors are delicate in floor and side wall-mounted positions. Periodic examination of these connectors for damage will prevent use of a connector with damaged pins or other connections, assuring proper operation of the connectors. Protect these connectors when they are not in use.

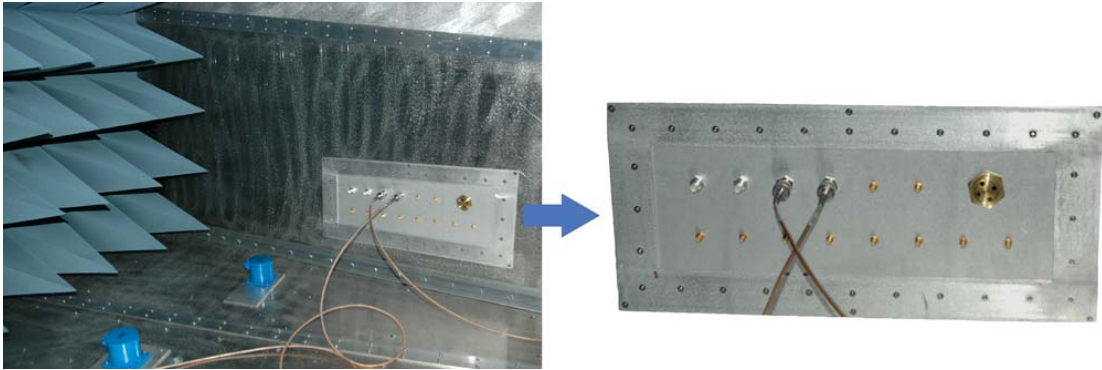

ABSORBER TIPS

The RF absorber tips are fragile and easily broken off. They may be easily replaced with almost any contact cement or with rapid-curing epoxy cement. If the tips are too damaged to reuse, they may be replaced by cutting off the entire tip at a point where the absorber body is about 10 cm by 10 cm, and then replacing the entire tip. Extra absorbers are available from the factory.

Absorber tip protectors are installed on some GTEM! cells where personal access inside is expected. These tip protectors are cut from block-expanded polystyrene. They will protect the tips from casual contact. Extra or replacement tip protectors are available from the factory.

SHIELDED VIEWING WINDOWS (OPTIONAL)

The shielded viewing windows are fabricated from an acrylic plastic material or toughened glass. Cleaning may be performed with a plastic cleaner or standard window cleaner. In both cases, make sure to limit run off onto the GTEM!.

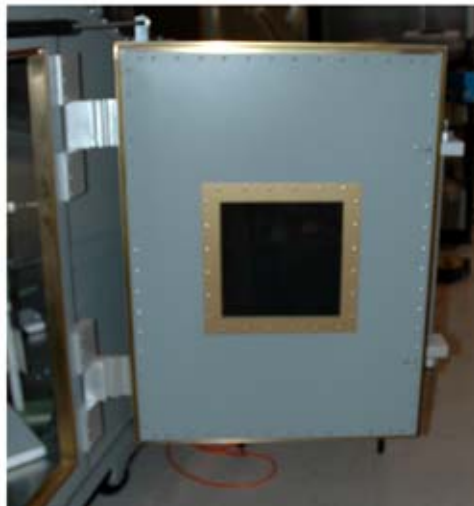

GTEM! CLEANING

Overall cleaning of the GTEM! inner and outer surfaces may be performed by the use of standard non-abrasive cleaners. Periodic cleaning of the interior with a vacuum cleaner will reduce the possibility of debris build-up in the connector panel area.

LOAD BOARDS

Load boards should not require maintenance, other than periodic inspection and cleaning of contact surfaces to prevent the occurrence of any film or corrosion. Any foreign substance that is found on the boards or connector surfaces should be removed.

Other Maintenance

Other maintenance or scheduled maintenance of the GTEM! is not required. Factory engineering personnel should be consulted in the event of damage or failure to operate properly after maintenance procedures.

In Case of Damage

If severe damage occurs to a GTEM!, contact ETS-Lindgren. Please have ready a description of the nature and scope of the damage.

3.0 Specifications

Physical Specifications

	Model 5402	Model 5405	Model 5407	Model 5411
Outer Cell Dimension (LxWxH):	L: 1.4 m (4.7 ft) W: 0.75 m (2.5 ft) H: 0.5 m (1.7 ft)	With base: L: 3.0 m (9.8 ft.) W: 1.6 m (5.2 ft) H: 1.7 m (5.6 ft) Without base: L: 3.0 m (9.8 ft.) W: 1.6 m (5.2 ft) H: 1.1 m (3.7 ft)	With base: L: 4.0 m (13.1 ft) W: 2.2 m (7.1 ft) H: 2.1 m (6.8 ft) Without base: L: 4.0 m (13.1 ft) W: 2.2 m (7.1 ft) H: 1.4 m (4.6 ft)	With base: L: 5.4 m (17.7 ft) W: 2.8 m (9.2 ft) H: 2.3 (7.5 ft)
Approx Cell Weight:	40 kg (88 lb)	250 kg (550 lb)	500 kg (1100 lb)	900 kg (2000 lb)
Door Dimension (WxH):	W: 160 mm (6.3 in) H: 230 mm (3.9 in)	W: 460 mm (18.1 in) H: 385 mm (15.2 in)	W: 686 mm (27.0 in) H: 747 mm (29.4 in)	W: 686 mm (27.0 in) H: 925 mm (36.4 in)
Max Septum Height:	250 mm (9.8 in)	550 mm (21.7 in)	75.0 mm (3.5 in)	1100 mm (43.3 in)
Highest Accuracy Transverse Test Surface in Center of Cell (WxH):	W: 76.2 mm (3 in) H: 76.2 mm (3 in)	W: 300 mm (11.1 in) H: 300 mm (11.1 in)	W: 400 mm (15.8 in) H: 400 mm (15.8 in)	W: 550 mm (21.5 in) H: 366 mm (14.3 in)
Distributed Load Rating:	N/A	250 kg (550 lb)	430 kg (950 lb)	750 kg (1650 lb)

Electrical Specifications

	Model 5402	Model 5405	Model 5407	Model 5411
Frequency Range:	RE TESTS ¹ 9 kHz–5 GHz RI TESTS DC – 20 GHz	RE TESTS ¹ 9 kHz–5 GHz RI TESTS ² DC – 20 GHz	RE TESTS ¹ 9 kHz–5 GHz RI TESTS ² DC – 20 GHz	RE TESTS ¹ 9 kHz–5 GHz RI TESTS ² DC – 20 GHz
VSWR (Typical):	Characteristic frequency: ≤1.5:1 All other frequencies: ≤1.75:1	Characteristic frequency: ≤1.5:1 All other frequencies: ≤1.75:1	Characteristic frequency: ≤1.5:1 All other frequencies: ≤1.75:1	Characteristic frequency: ≤1.5:1 All other frequencies: ≤1.75:1
Maximum CW Input Power:	100 W	250 W 400 W with optional blower	200 W 500 W with optional blower	1000 W
Input Impedance:	50 Ω	50 Ω	50 Ω	50 Ω
Feed Connector Type:	CW 7/16 DIN plug to N jack adaptor	CW 7/16 DIN plug to N jack adaptor	CW 7/16 DIN plug to N jack adaptor	CW 7/16 DIN plug to N jack adaptor
Shielding Effectiveness:	From internal E-fields: 80 dB minimum 10 kHz–1 GHz	From internal E-fields: 80 dB minimum 10 kHz–1 GHz	From internal E-fields: 80 dB minimum 10 kHz–1 GHz	From internal E-fields: 80 dB minimum 10 kHz–1 GHz

¹Frequency range where OATS correlation demonstrated

²Low VSWR to $f \geq 20$ GHz; performance dependent on field uniformity tolerance

³Characteristic frequency: Resistor Absorber crossover frequency

4.0 GTEM! Assembly

The Gigahertz Transverse Electromagnetic (GTEM![™]) Cell is shipped in one or more plywood crates, or in certain circumstances, may be shipped partially assembled. Large GTEM! cells are shipped in multiple crates. The assembly drawings on pages 28–30 provide pertinent outer dimensions and floor space requirements for the Model 5405, Model 5407, and Model 5411.

The Model 5400 Series is designed for easy assembly. Typically, only standard hand tools are required.

The Model 5402 and Model 5405 are normally shipped fully assembled. Due to the size of the shipping crates for the Model 5405 or size of the standard factory-assembled subassemblies, it may be necessary to ship in smaller sections. In this case, a factory technician or authorized ETS-Lindgren installer will perform the installation. This should be arranged at the time of the order.

The Model 5407 and Model 5411 are shipped partially assembled or unassembled. A factory installer or authorized ETS-Lindgren installer will perform the installation.



The Model 5407 and Model 5411 are shipped with a comprehensive installation manual. For complete information on uncrating, assembling, and installing, see the installation manual shipped with the Model 5407 and Model 5411.

While installation and calibration by the customer is possible, it is recommended that a qualified ETS-Lindgren installer provide those services.

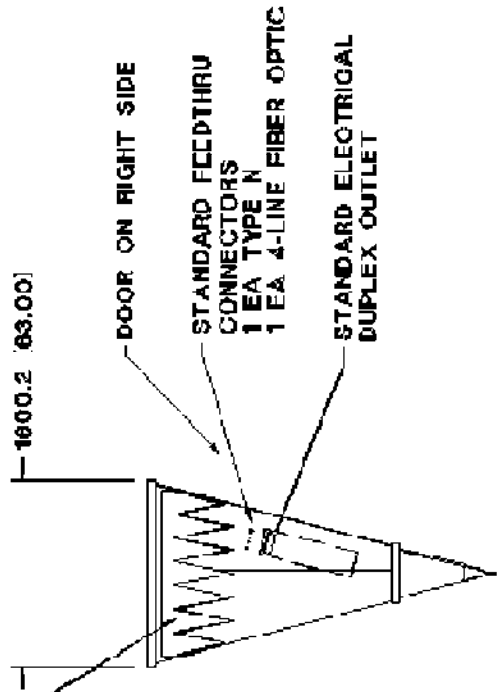

FLOOR LAYOUT

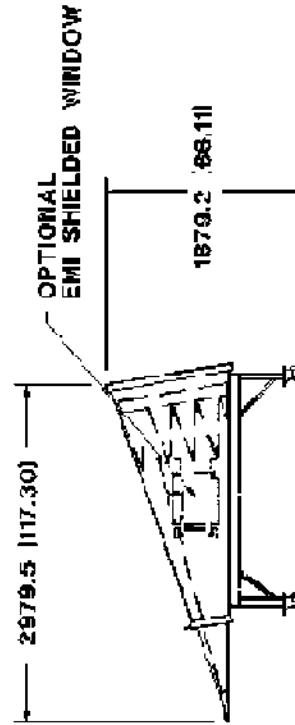

RIGHT SIDE VIEW

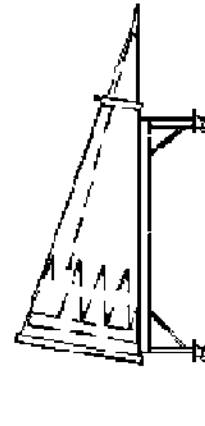

LEFT SIDE VIEW

NOTES:

1. PRIMARY DIMENSIONS SHOWN ARE IN MILLIMETERS. SECONDARY IN BRACKETS ARE IN INCHES.
2. IMPORTANT SHIPPING INFORMATION
 STANDARD GTEM 5405 IS SHIPPED COMPLETELY ASSEMBLED. CUSTOMER NEEDS TO ENSURE THAT THE ASSEMBLED UNIT CAN BE ROLLED THROUGH EXISTING DOORWAYS LEADING TO FINAL TEST SITE. MANUFACTURER SUGGESTS AT LEAST 1825.6 (64.0) WIDE BY 1727.2 (68.0) HIGH CLEAR OPENINGS.

NOTES:

1. PRIMARY DIMENSIONS SHOWN ARE IN MILLIMETERS. SECONDARY IN BRACKETS ARE IN INCHES.
2. **IMPORTANT SHIPPING INFORMATION**
STANDARD GTEM 5407 IS SHIPPED UNASSEMBLED, EXCEPT FOR FEED SECTION OF CELL

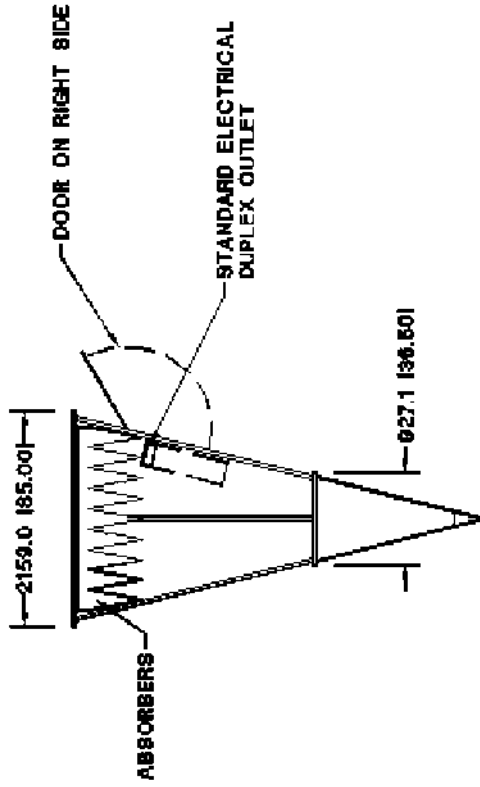

FLOOR LAYOUT

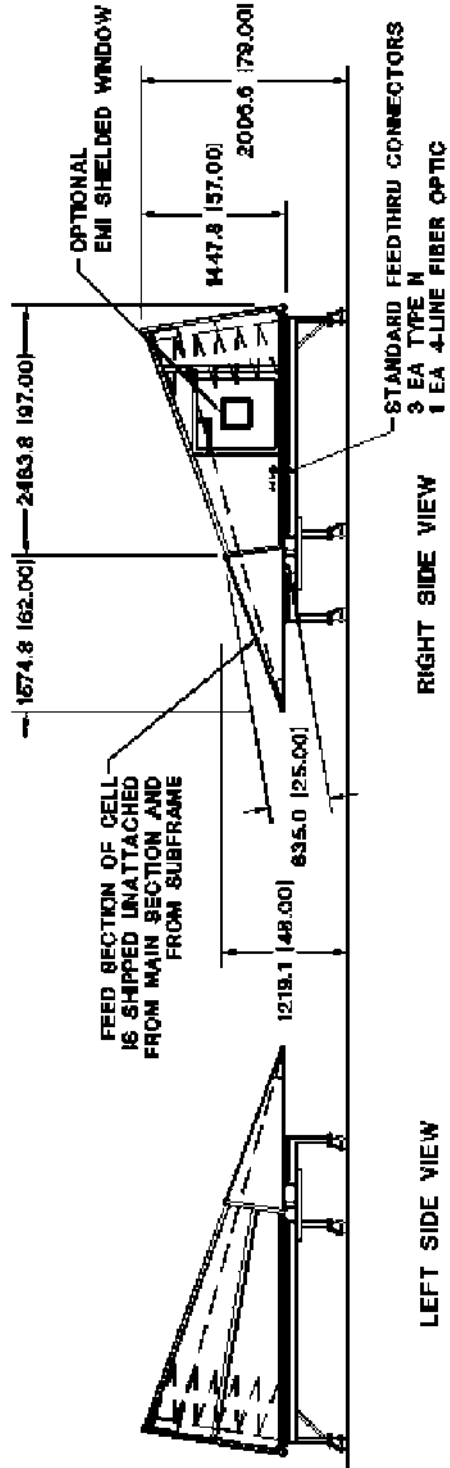

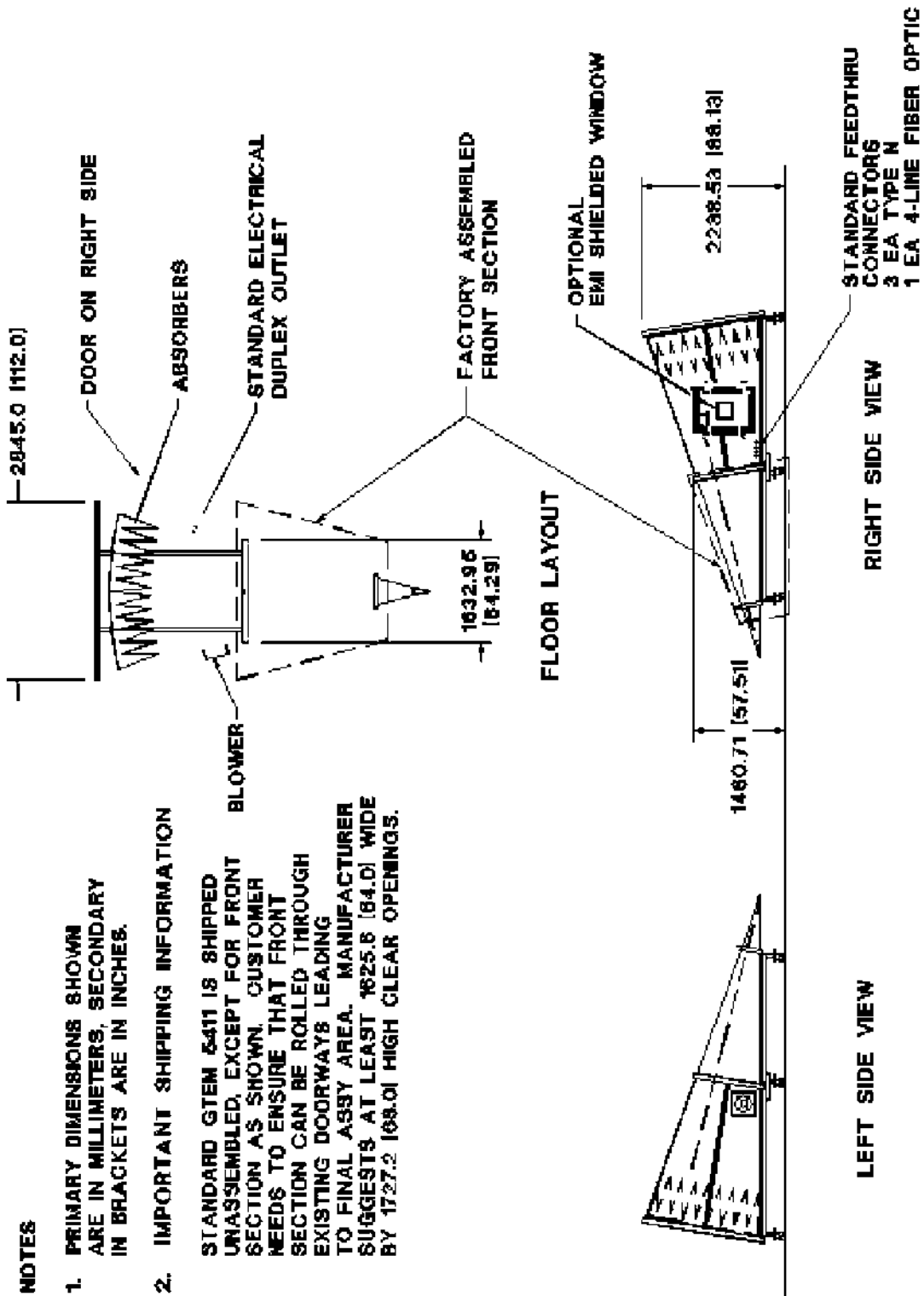

5.0 Measured GTEM! Performance

Several different measurable quantities exist that illustrate the performance of a Gigahertz Transverse Electromagnetic (GTEM!TM) Cell. Typical measurements are discussed in this section.

GTEM! Performance Qualification – VSWR

The Voltage Standing Wave Ratio (VSWR) of a terminated transmission line is a fundamental performance parameter. The value of the VSWR reading is a measure of mismatch; therefore, it completely defines the capability of a GTEM! to transfer power to or from interconnected 50-ohm RF test equipment. The VSWR is a qualifying measurement for GTEM! cells. Most GTEM! cells are pre-assembled at the factory and the VSWR verified at that time. Following is the VSWR of a typical Model 5407 measured with an HP8753C vector network analyzer.

TYPICAL VSWR MEASUREMENT – MODEL 5407

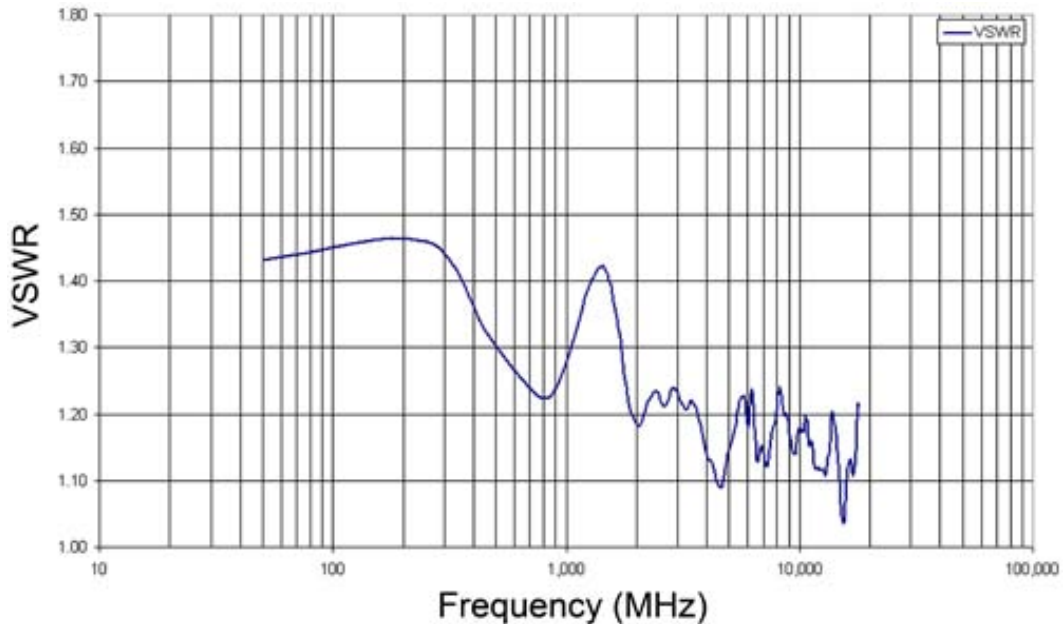

E-FIELD FREQUENCY RESPONSE

The E-field frequency response is defined as the measurement of the electric field strength at a specific point in the GTEM! measured as a function of frequency and normalized to a constant forward input power.

TYPICAL E-FIELD FREQUENCY RESPONSE – MODEL 5407

Following is a typical Model 5407 vertical electric field frequency response normalized to 10 W constant forward power at a center point where the septum height is 80 cm (40 cm above the floor). At other locations electric field frequency response can vary by several dB.

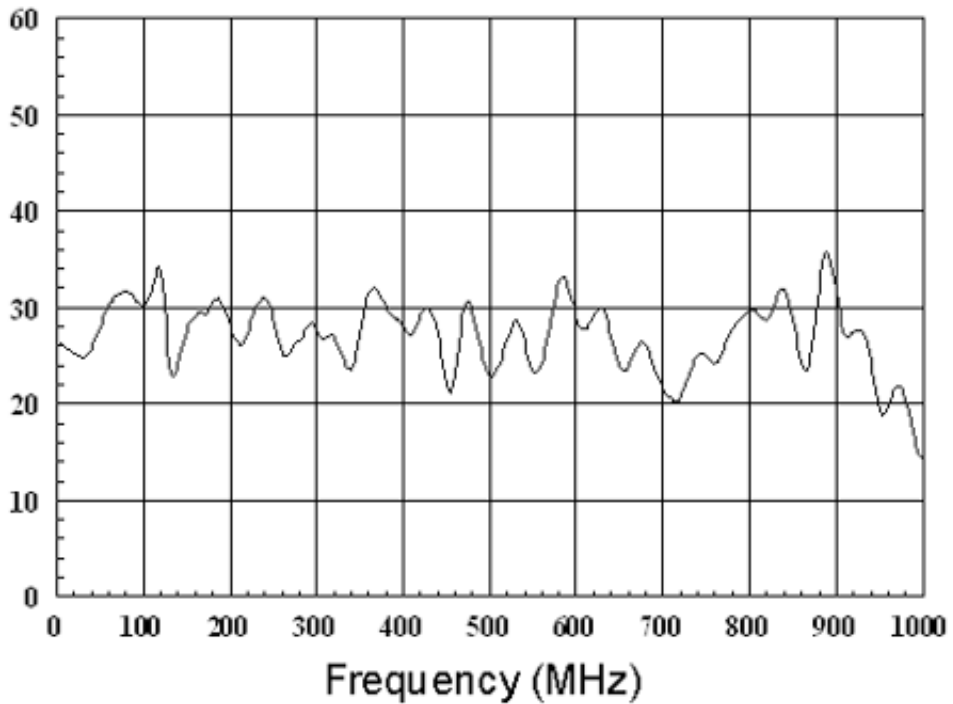

ELECTRIC FIELD UNIFORMITY

The electric field uniformity of a GTEM! can be defined as the maximum difference in dB between measured electric field at various spatial locations on a plane perpendicular to the direction of propagation. According to the IEC 61000-4-20 standard, the uniform area to be measured and the minimum number of points depend on the size of the GTEM!. At each frequency, the reference location can be arbitrarily chosen; for example the center or bottom corner point of the calibration plane. After performing the plane calibration in the empty GTEM!, the Equipment Under Test (EUT) is inserted with the front face coincident with the calibration plane.

TYPICAL ELECTRIC FIELD UNIFORMITY – MODEL 5407

The electric field uniformity of a Model 5407 as measured according to EN 61000-4-20 is shown in the following. Five spatial points were measured in a 633 mm x 250 mm vertical/transverse plane centered at an 80-cm septum height. The standard allows 25% of the points to be omitted at each frequency; at least four of the five points fulfill the $-0, +6$ dB criteria as required.

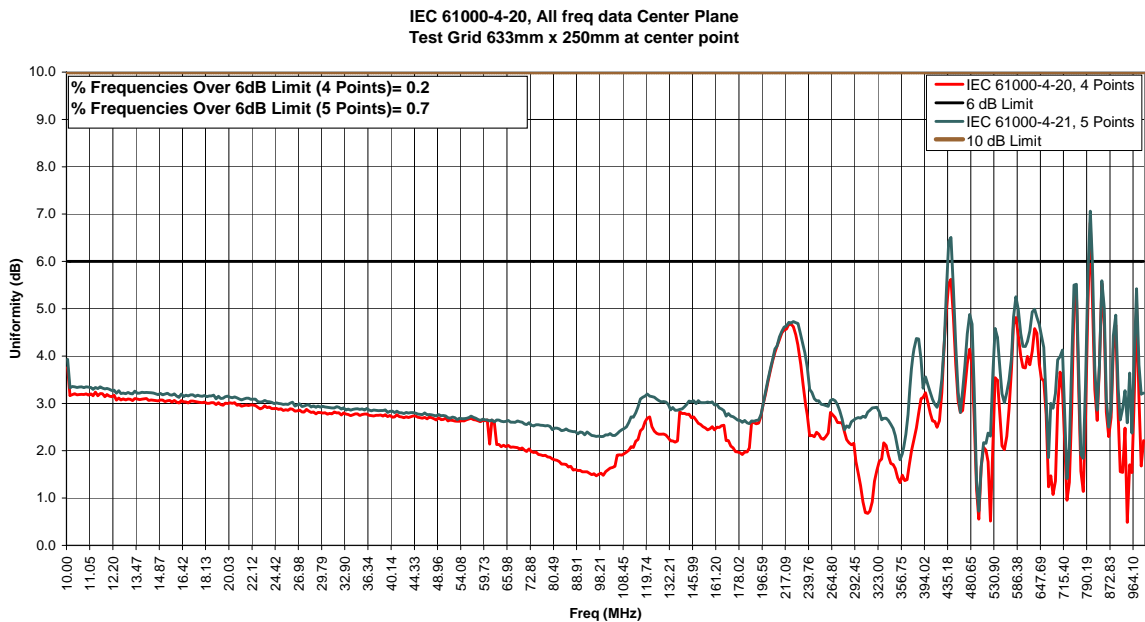

TIME DOMAIN REFLECTOMETER

The Time Domain Reflectometer (TDR) Measurement is an impedance measurement performed in the time domain. The advantage here is that distance information can be derived from the test and used to confirm the correct alignment of the septum and other cell components along the length of the cell. The TDR test is generally performed as standard at the factory on assembled cells.

GTEM! Shielding Effectiveness

The shielding effectiveness (SE) of a GTEM! is difficult to measure by conventional IEEE-299-type methods due to GTEM! size and flared walls. Alternative methods have been developed, for example: The primary technical issue is the choice of reference signal for the SE tests. Due to size constraints, normal antennas cannot be used to generate the signal inside the GTEM!. In addition, electric field intensity along the GTEM! can vary more than 20 dB from apex to load. For these reasons, a modified two-antenna swept-frequency procedure was used to measure SE of the Model 5400 Series. In this method, power is input into the GTEM! as in a normal immunity test, and the receive readings of two loop probe antennas, one inside and the other outside the GTEM! walls, are compared. For the Model 5407, a >80 dB specification SE was verified with this method.

GTEM! Emissions Testing Characterization

A representative radiated emissions comparison of a GTEM! measurement to an Open Air Test Site (OATS) measurement is provided in detail in *Appendix C, Radiated Emissions Test Performance of GTEM!* on page 71.

6.0 GTEM! Use

The intended use of the Gigahertz Transverse Electromagnetic (GTEM!TM) Cell is for radiated immunity testing and radiated emissions testing. The following sections on GTEM! usage provide a general overview of these uses. Note that the test operator, as with any test facility, must plan and implement the testing of all devices thoroughly to ensure repeatable results.

Radiated Immunity Testing

Radiated immunity testing is conducted to ascertain if the Equipment Under Test (EUT) will respond to radiated energy in the electromagnetic ambient in a deleterious manner. The GTEM! provides an ideal facility for the accomplishment of such tests in a laboratory environment. Immunity testing is typically performed using either of the following techniques.

SUBSTITUTION METHOD

This method uses the principle of calibrating the test volume. An E-field probe is positioned in the center of the test plane and the input power is increased until the required test field is measured. The input power is then recorded as a function of frequency to create an empty volume calibration file.

For the test, the field probe is replaced by the EUT and the forward power values of the calibration file are replayed while the device is monitored.

DIRECT METHOD

In this method the field probe and EUT are both placed in the GTEM! and the forward power increased until the required field is measured. This is repeated for each frequency as the EUT is monitored.

The test setup usually consists of the components shown in *Typical Automated Radiated Immunity Test Setup* on page 38.

Estimation of GTEM! RF Input Power Required for Given Field Strength

The standard RF power-handling capability of the Model 5405 and Model 5407 is in excess of 200 W. The standard RF power-handling capability of the Model 5411 is 1000 W. Greater voltage or power-handling capabilities are possible if modified feed sections, load boards, or optional blowers are installed. Field intensities in excess of 200 V/m can be generated with sufficient CW power.

Estimation of the power required for obtaining a given field strength is easy. Using the parallel-plate electric field approximation, the estimated field strength halfway between the septum and the floor of the GTEM! is given by the ratio of the RF voltage on the septum to the spacing of the septum above the GTEM! floor, or:

$$E(\text{Volts/meter}) = V (\text{Volts}) / h (\text{meters})$$

RF voltage is obtained from the drive power by the equation:

$$P_{in} (\text{Watts}) = V^2 (\text{Volts}^2) / Z_0 (\text{Ohms})$$

Where P_{in} is input RF Power (Watts), V is RF voltage on the septum at height h , and Z_0 is the GTEM! characteristic impedance (50 ohms).

Then a simple solution is:

$$E = \left(\frac{1}{h} \right) (P \times Z_0)^{1/2}$$

$$P = \frac{(Eh)^2}{Z_0}$$

The previous equations can be used for first order estimates of field strength given power, or power required for a given field strength. Power required calculated by this method is approximate, and actual power needed for a given electric field strength will vary versus frequency and location in the GTEM!.

TYPICAL 10 V/M POWER REQUIRED – MODEL 5400 SERIES

Following is the typical measured power required for 10 V/m at a 0.9-m septum height (40 cm height above floor and 80 cm septum height) in a Model 5400 Series.

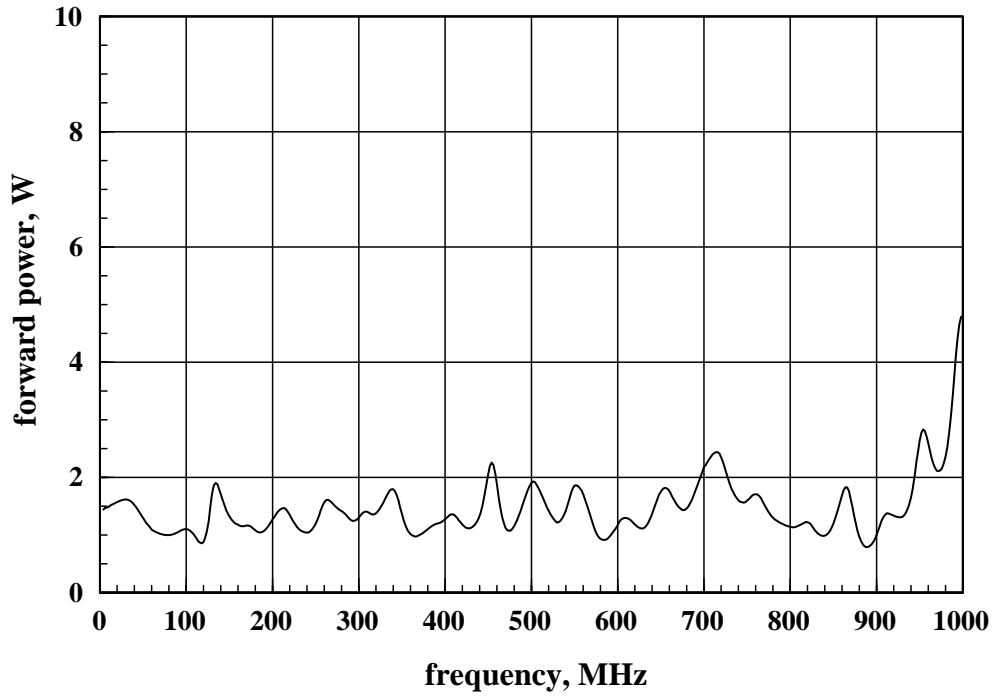

TYPICAL AUTOMATED RADIATED IMMUNITY TEST SETUP

Following is a typical setup for conducting radiated immunity testing using automated control techniques. Testing can be completely automated if it is possible to define a test signal response from the EUT, which can be sensed by the controlling computer. A signal generator is shown with an external modulation source so that the modulation characteristics can be matched, if desired, to signals internal to the EUT. The output of the signal generator is applied to the RF power amplifier, which in turn drives the GTEM!. Application of the signal to the GTEM! input produces the test signal between the septum and the floor of the GTEM!. Internal to the GTEM!, an optional broadband, high-level isotropic probe monitors the level of the applied signal. An isotropic field probe may be used to sense the applied field at different locations and report actual electric field strength values.

The EUT is installed in the GTEM! in the approximate center of the test volume.

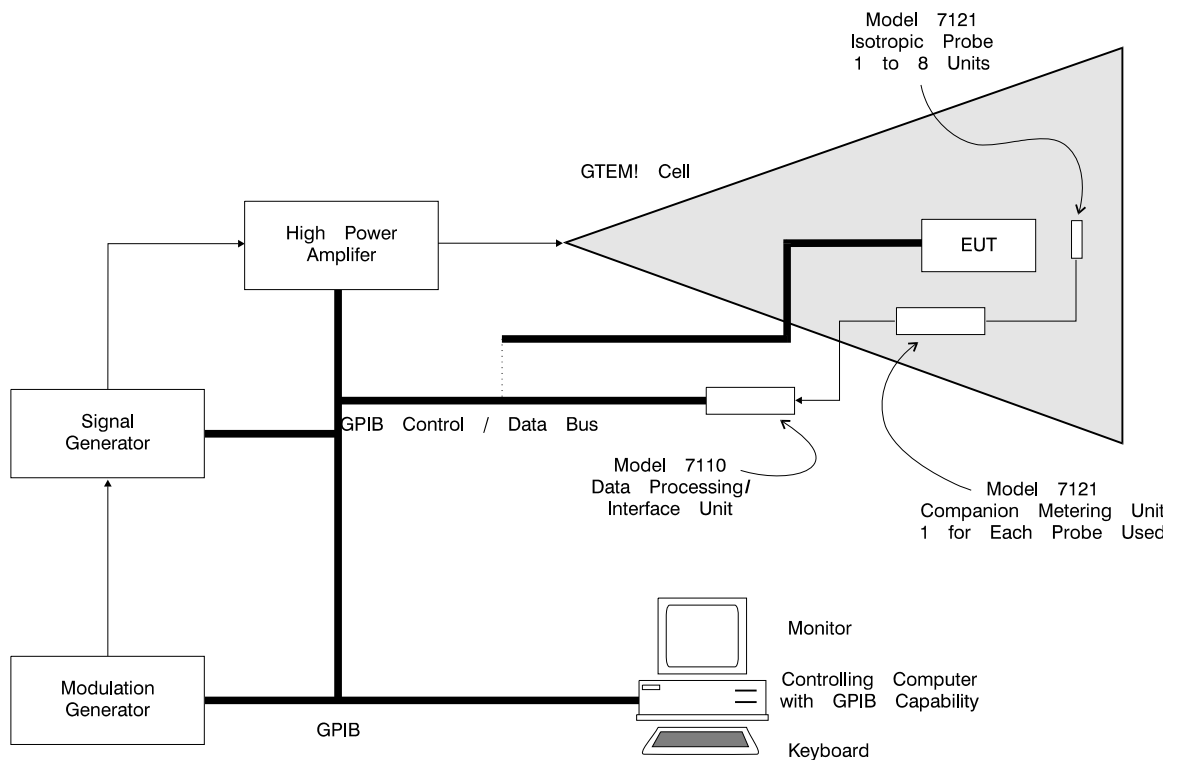

Monitoring of EUT performance is via a cable to any externally located monitor unit. Typical precautions must be taken, such as are used in shielded enclosure immunity testing with EUT performance monitors. An example would be grounding the shield of the cable to the performance monitor to the bottom of the GTEM!. Once the setup is complete, the signal generator is turned over the test frequency range while monitoring the performance of the EUT for response to the applied test signal. The levels of the test signal are adjusted by controlling the signal generator output while monitoring for the minimum field level at the location of the isotropic probe.

Note that the electric field strength and the sweep speeds are often set by the test requirements document(s). Care should be taken not to exceed specified sweep speeds. An additional factor is that, with the availability of automated testing, it is possible to sweep at the specification-required speed without consideration of the performance of the EUT. If the EUT must be stepped through a number of modes at each frequency, then even slower sweep speeds may be needed.

Radiated Emissions Testing – General

In addition to immunity testing, the GTEM! may be used for radiated emissions testing. An item placed in the test volume under the septum can be evaluated for radiated emissions as easily and as simply as an immunity test is accomplished. By the reciprocity principle in electromagnetic theory, if the application of an RF voltage generates a field, then the introduction of a device that radiates a field in the volume under the septum will produce an RF voltage at the GTEM! input connector. The voltage produced will be proportional to the intensity of the radiated field.

The main development that brought the GTEM! forward as a practical radiated emissions device was the three-position correlation algorithm (derived by Wilson et al. at ABB, based on results from NIST), which allowed the direct comparison of data taken in a GTEM! to data acquired on an Open Area Test Site (OATS). The GTEM! feed connector voltages produced by radiated emissions from the EUT at each of three orthogonal positions are measured. Then at each frequency, an equivalent set of dipole antennas that would produce the same voltages at the GTEM! connector are defined through computer computation. Once the equivalent antennas are defined, the field intensities for comparison to the given specification limit are computed from the set of equivalent dipoles at each frequency, given the separation and geometry of the test setup on an OATS.

The simplest GTEM! to OATS correlation algorithm uses three EUT positions. Various other rotation schemes have been described developed. Please contact ETS-Lindgren for additional details.

Radiated Emissions Measurements – Hardware Requirement

Measurement of radiated emissions requires the use of a frequency-selective EMI meter or spectrum analyzer. For manual use, any calibrated receiver typically used for electromagnetic compatibility (EMC) measurements is acceptable as long as the test specification requirements for the measurement device are met.

EUT Orientation for Testing

Proper orientation of the EUT in three orthogonal axes is necessary to accurately perform radiated emissions measurements. To perform the EUT rotations, separate coordinate axes are defined for the GTEM! and the EUT. The mathematical model for the correlation to an OATS and the need for the three orthogonal rotations is described in *Appendix B, Emission Measurements in TEM Cells and TEM Lines* on page 69.

The three reference orthogonal axes of the GTEM! are normally defined as:

- **Positive Z-axis:** to the feed
- **Positive Y-axis:** up
- **Positive X-axis:** toward the right of the cell as seen from the apex

Note that this is a positive right rectangular coordinate system; X rotated into Y in a right-handed sense gives a positive-Z. In this discussion the uppercase letters X, Y, and Z represent the axes of the GTEM! , and the lowercase letters x, y, and z represent the EUT right axes.

The mathematical formulation of the GTEM! model for determining the OATS-equivalent value of radiated emissions requires three measurements of voltage produced by the EUT in three orthogonal axes positions. In the rotation scheme, the three positions must be aligned with the axes of the cell as follows:

Position 1: GTEM! axes XYZ
EUT axes xyz

Position 2: GTEM! axes XYZ
EUT axes yzx

Position 3: GTEM! axes XYZ
EUT axes zxy

The EUT array, a personal computer system installed on a plywood panel per the requirements of ANSI 63.4-1992, is shown with the x, y, z EUT axes aligned with the X, Y, Z GTEM! axes. Note that the EUT and GTEM! axes are shown in alignment at the top, right sides, and bottom of *Typical EUT System Installed in Large GTEM!* on page 43. The circle with the dot at the center located at the bottom of the illustration represents the tip of the axis arrowhead pointing out.

In position two, the EUT is rotated so that the y-axis aligns with the X-axis, the z-axis aligns with the Y-axis, and the x-axis aligns with the Z-axis. *Typical EUT System Installed in Large GTEM! (90° Rotation)* on page 44 demonstrates the alignment of the GTEM! and EUT axes for this rotational position.

In position three, the EUT is rotated so that the x-axis aligns with the X-axis, the y-axis aligns with the Y-axis, and the z-axis aligns with the Z-axis. *Typical EUT System Installed in Large GTEM! (Additional 90° Rotation)* on page 45 shows the third position.

Measurement Procedure

The following general procedure should be used to perform radiated emissions measurements in a GTEM!. This procedure is written for manually-performed measurements.

1. Install the EUT in the center of the test volume of the GTEM! with a reference orientation, as shown in *Typical EUT System Installed in Large GTEM!* on page 43 and as described previously for the first position.
2. Measure the RF voltages emanating from the EUT as a function of frequency over the desired frequency range. Depending on the measurement device used, either peak, quasi peak, or average measurements may be made. These measurements are collectively referred to as V_{xyz} versus frequency.

3. Rotate the EUT through two successive 90-degree rotations to the right, such that the x-axis is replaced by the y-axis, and so on, as shown in *Typical EUT System Installed in Large GTEM! (90° Rotation)* on page 44.
4. Measure the RF voltages emanating from the EUT as a function of frequency over the desired frequency range. These measurements are referred to as V_{yzx} versus frequency.
5. Rotate the EUT through further 90-degree rotations to the right, such that the y-axis is replaced by the z-axis, and so on, as shown in *Typical EUT System Installed in Large GTEM! (Additional 90° Rotation)* on page 45.
6. Measure the RF voltages emanating from the EUT as a function of frequency over the desired frequency range. These measurements are referred to as V_{zxy} versus frequency.



The detector selected (peak, quasi peak, or average) must be used for all three-position measurements and the frequency of the measurements must be the same for all positions.

After completion of these measurements, the tester should have a matrix of measurements that consists of a frequency and three associated RF voltage measurements all made with the same detector function. A value for the noise measured at a given frequency where signal components were measured may be necessary to complete the measurement set.

To assist with the computation, you may download an MS-DOS®-based utility program from the ETS-Lindgren website at www.ets-lindgren.com. This type of program should be used because the computations are too complex to be performed by hand in a reasonable amount of time.

TYPICAL EUT SYSTEM INSTALLED IN LARGE GTEM!

This view is seen from the apex with GTEM! (X, Y, Z) and EUT (x, y, z) axes aligned for measurement of V_{xyz} .

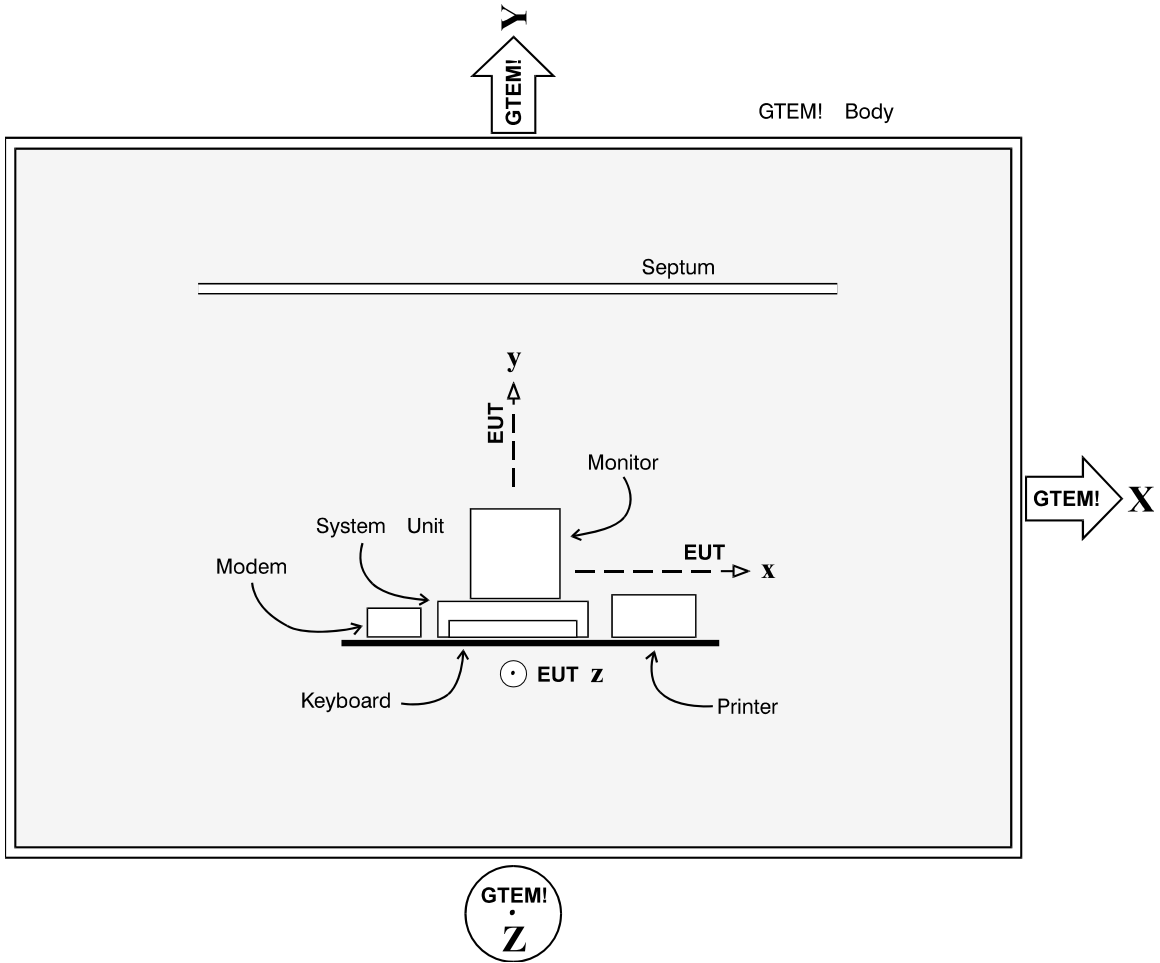

TYPICAL EUT SYSTEM INSTALLED IN LARGE GTEM! (90° ROTATION)

This view is seen from the apex with GTEM! (X, Y, Z) and EUT (y, z, x) axes aligned for measurement of V_{yzx} .

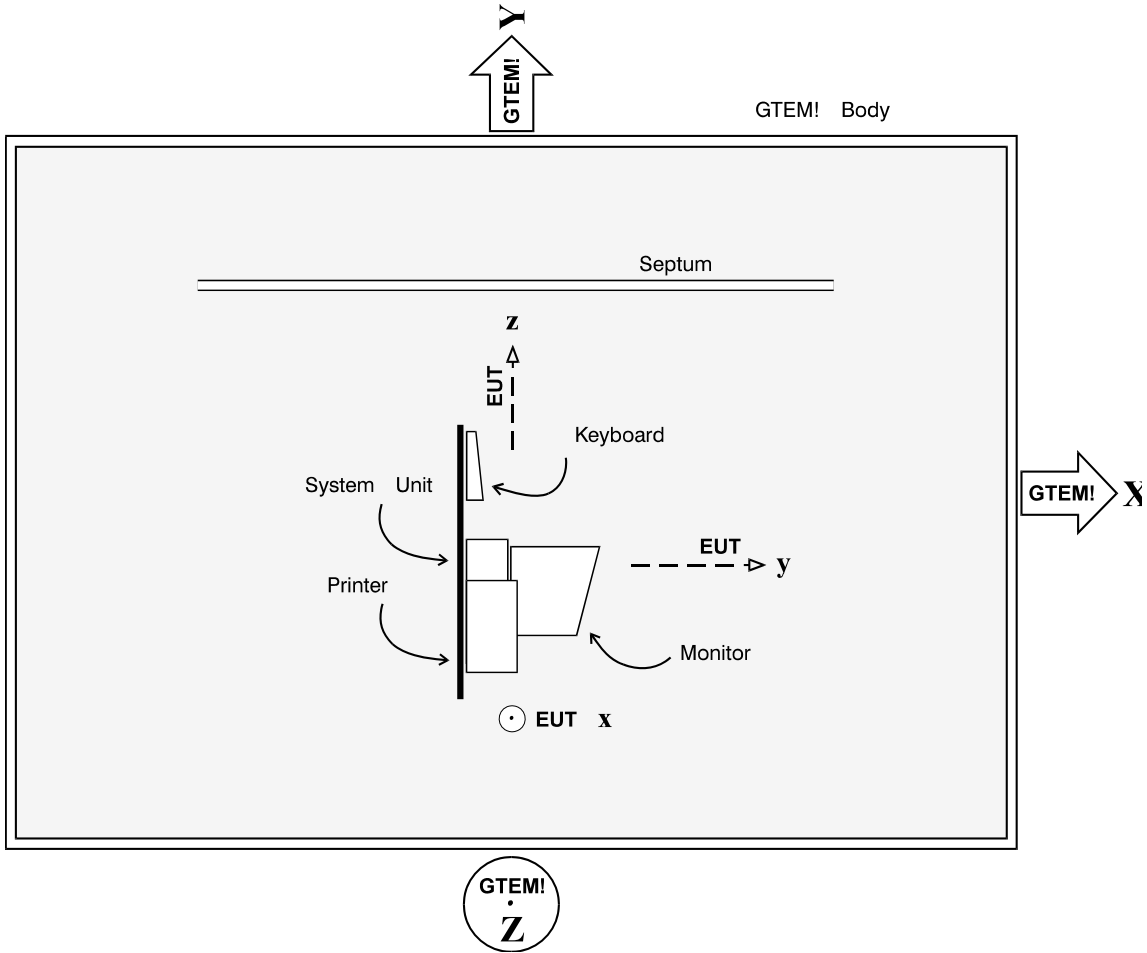

**TYPICAL EUT SYSTEM INSTALLED IN LARGE GTEM!
(ADDITIONAL 90° ROTATION)**

The view is from the apex with GTEM! (X, Y, Z) and EUT (z, x, y) axes aligned for measurement of V_{zxy} .

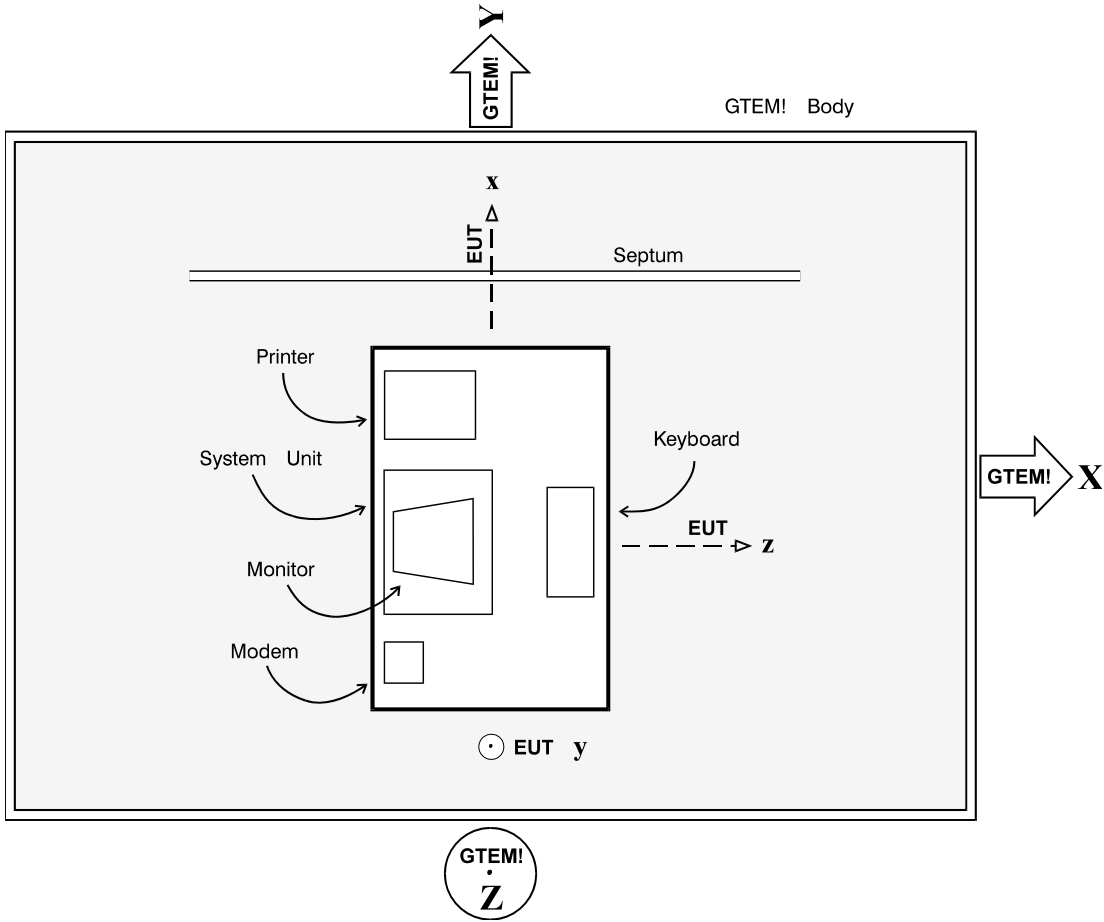

Software Computations

The correlation algorithm software for the GTEM! performs the calculations as outlined in the following.

At each frequency, the three-position correlation algorithm:

- Performs a root sum of the squares summation of the three orthogonal voltages.
- Computes the total power emitted by the EUT as determined from the summation of the three voltages and the transverse electromagnetic mode (TEM) mode equations for the GTEM!.
- Computes the current excitation of an equivalent tuned, half-wave Hertzian dipole when excited with that input power.
- Computes the field intensity at appropriate height intervals over the total, operator selected scan height, either one to four meters or two to six meters for both vertical and horizontal polarizations of the receive antenna when the equivalent turned resonant dipole is placed at an appropriate height over a perfect ground plane.
- Selects the maximum field strength (larger) value of the horizontal or vertical polarizations.
- Presents this maximum value for comparison to the chosen EMC specification limit.

The GTEM! feed connector voltages produced by radiated emissions from the EUT at each of three orthogonal axes are measured, then at each frequency an equivalent set of fixed dipole antennas that would produce the same voltages at the GTEM! connector are defined through computer computation. Once these equivalent antennas are defined, the OATS field intensities are computed for the distances and height scans selected. The calculated OATS data is then presented for comparison to actual OATS data if available based on an OATS emission limit.

The accuracy of the measurement is of prime importance. A report on the relative accuracy of the GTEM! for radiated emissions measurements is provided in *Appendix C, Radiated Emissions Test Performance* on page 71.

7.0 Ortho-Axis Positioner – Pneumatic (Optional)

The Ortho-Axis Manipulators for the Model 5405, Model 5407, and Model 5411 are air-driven devices used to assist in positioning the Equipment Under Test (EUT) during EMC measurements.

The manipulator is designed to automate the positioning of EUT inside the Gigahertz Transverse Electromagnetic (GTEM!™) Cell. A custom serial interface is used to control the movement of the manipulator.



Position the manipulator in the GTEM! as far back as possible, making sure to clear the absorbers and any floor penetration panels. The mounting platforms for the different models can support the following loads:

5405: Can support up to 4.5 kg

5407: Can support up to 4.5 kg

5411: Can support up to 20 kg

The EUT should always be positioned centrally and supported securely using the provided straps before the positioner is operated.

CAUTION

To prevent injury: Make sure that the manipulator cannot be operated remotely while inside the chamber or mounting the EUT to the platform.

Operation

A control unit containing pneumatic control relays is to be mounted to the exterior of the GTEM!. Four pneumatic control lines connect the control unit to the manipulator through four separate feed-through fittings on the side wall of the GTEM!.

Inline flow control valves mounted on the air cylinders of the manipulator regulate the speed of the manipulator movement. The valves can be adjusted to increase or decrease the airflow. The unit is to be connected to a customer-supplied air source. This air source will need to deliver a minimum of 1 CFM at 60 psi (30 psi for the Model 5405). It is important to have clean, dry air. We recommend the use of a 40-micron filter in close proximity to the installation.

A 12-volt DC wall-mounted power supply provides the DC power to the control unit. It connects to the control unit through a two-pin receptacle on the side of the enclosure. A serial cable connects the control unit to the serial port in the computer. A nine-pin D-sub connector is mounted on the side of the control unit for this connection.

Place the positioner in the GTEM! so that the recess in the base plate fits over the center strip in the GTEM!. The mounting plate will be positioned in one of the three orthogonal positions within the GTEM! at each of the fixed positions.

The Ortho-Axis Positioner can be controlled through Hyperterminal or other control software. If using Hyperterminal, the settings must be as follows:

Baud:	9600
Data Bits:	8
Parity:	None
Stopbits:	1
Flow Control:	None

The commands to control the positioner are:

	Bit 01	Bit 02
Position 1	\$CB01	\$CB02
Position 2	\$SB01	\$CB02
or	\$CB01	\$SB02
Position 3	\$SB01	\$SB02

<p># - Transmitted on startup \$ - Used to denote commands * - The response for valid commands ER – The response for invalid commands SBxx = Sets corresponding Bit high – for example, \$SB01 CBxx = Clear corresponding Bit – for example, \$CB01 RBxx = Read corresponding Bit – for example, \$RB01 *1 if Bit is set *0 if Bit is clear RR = Resets the control unit – for example, \$RR</p>

Functional Schematic

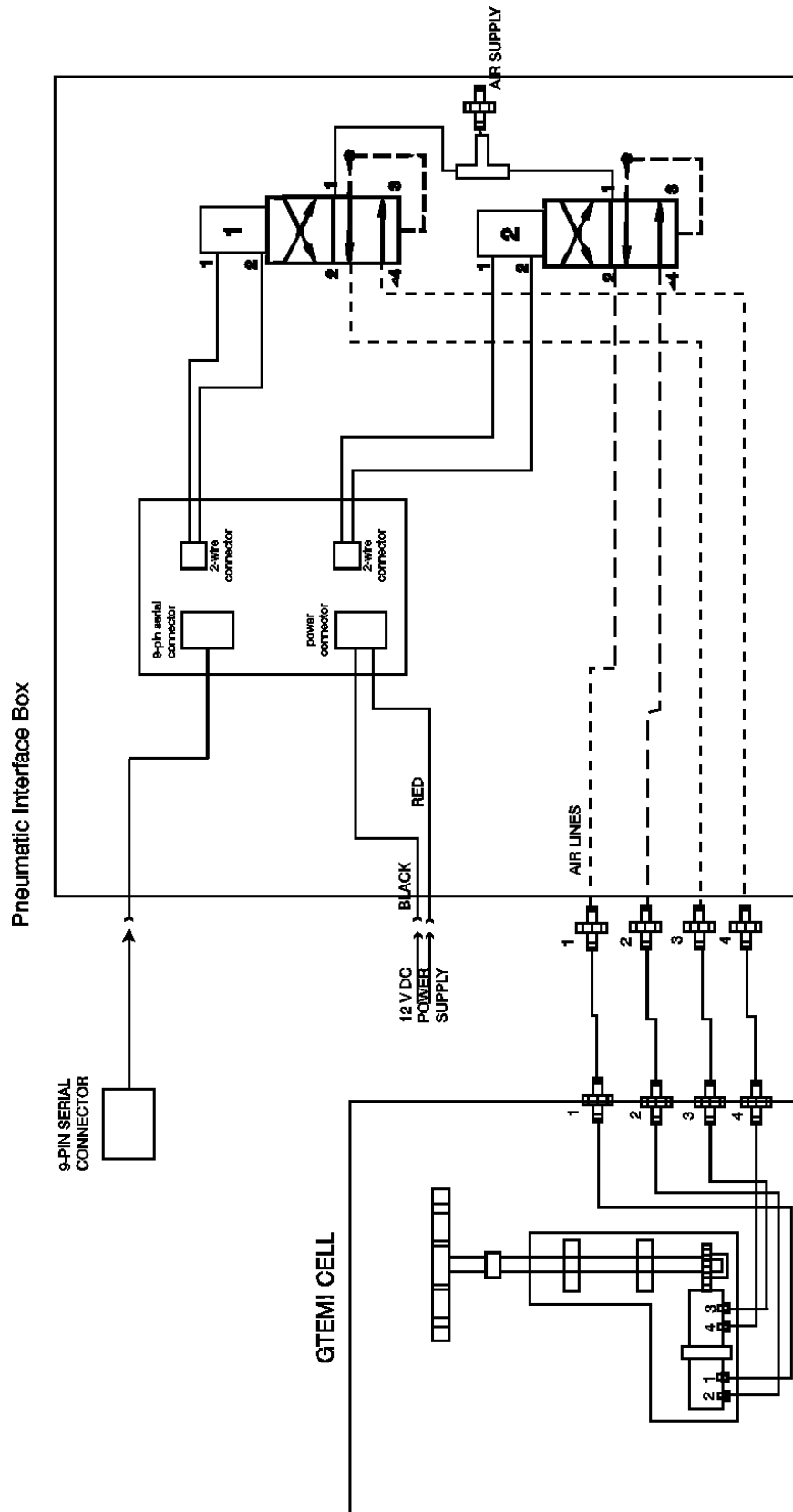

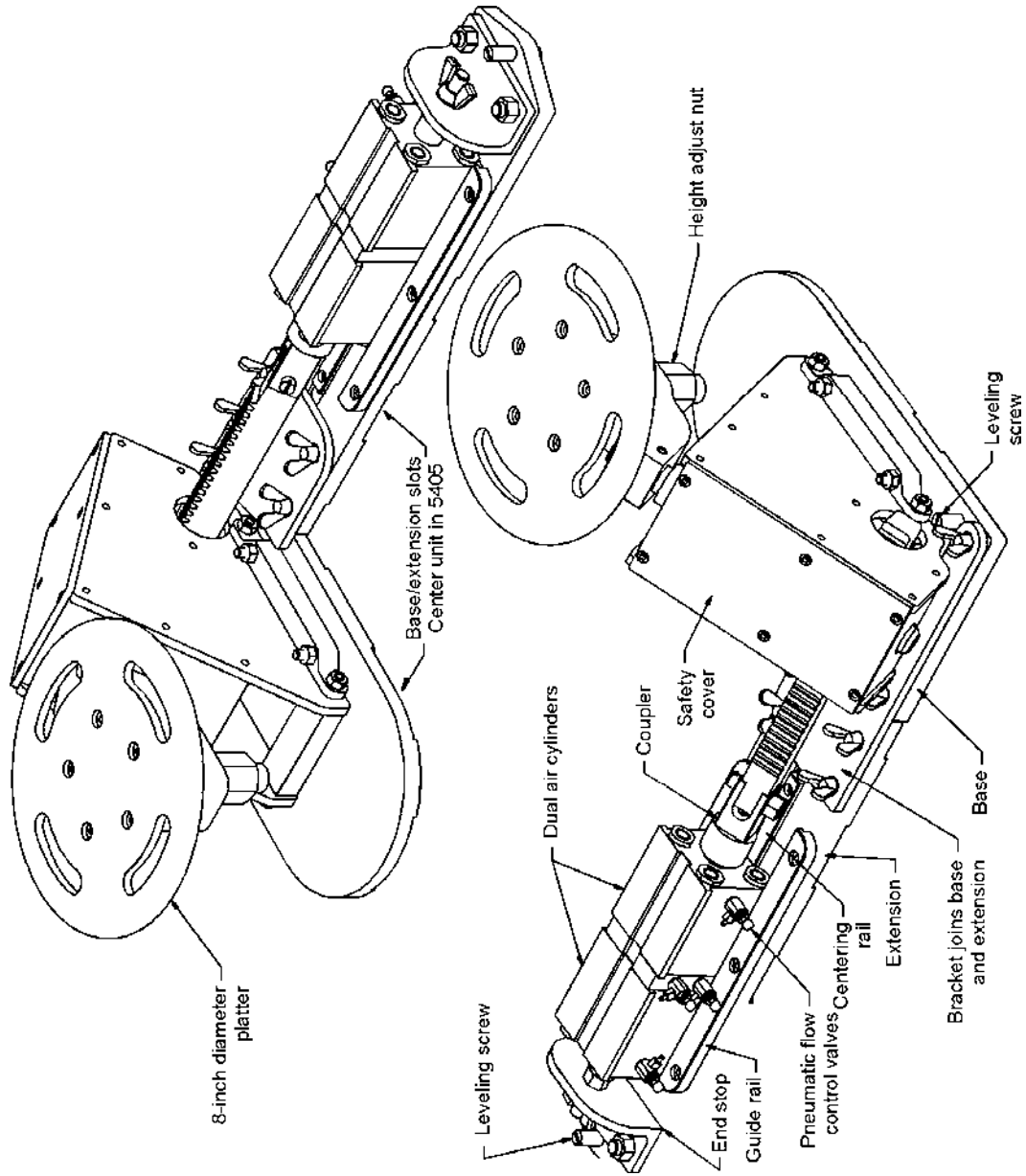

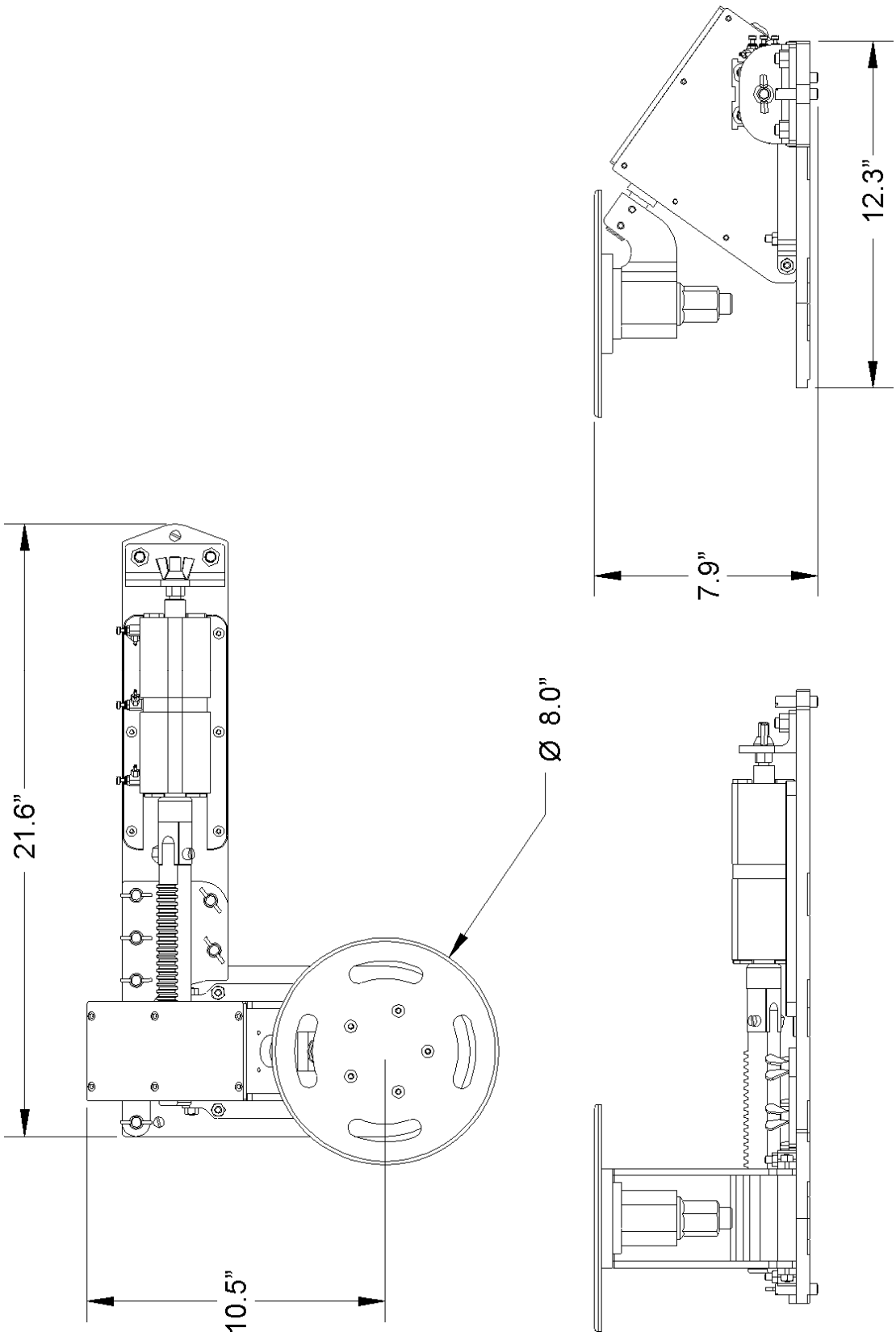

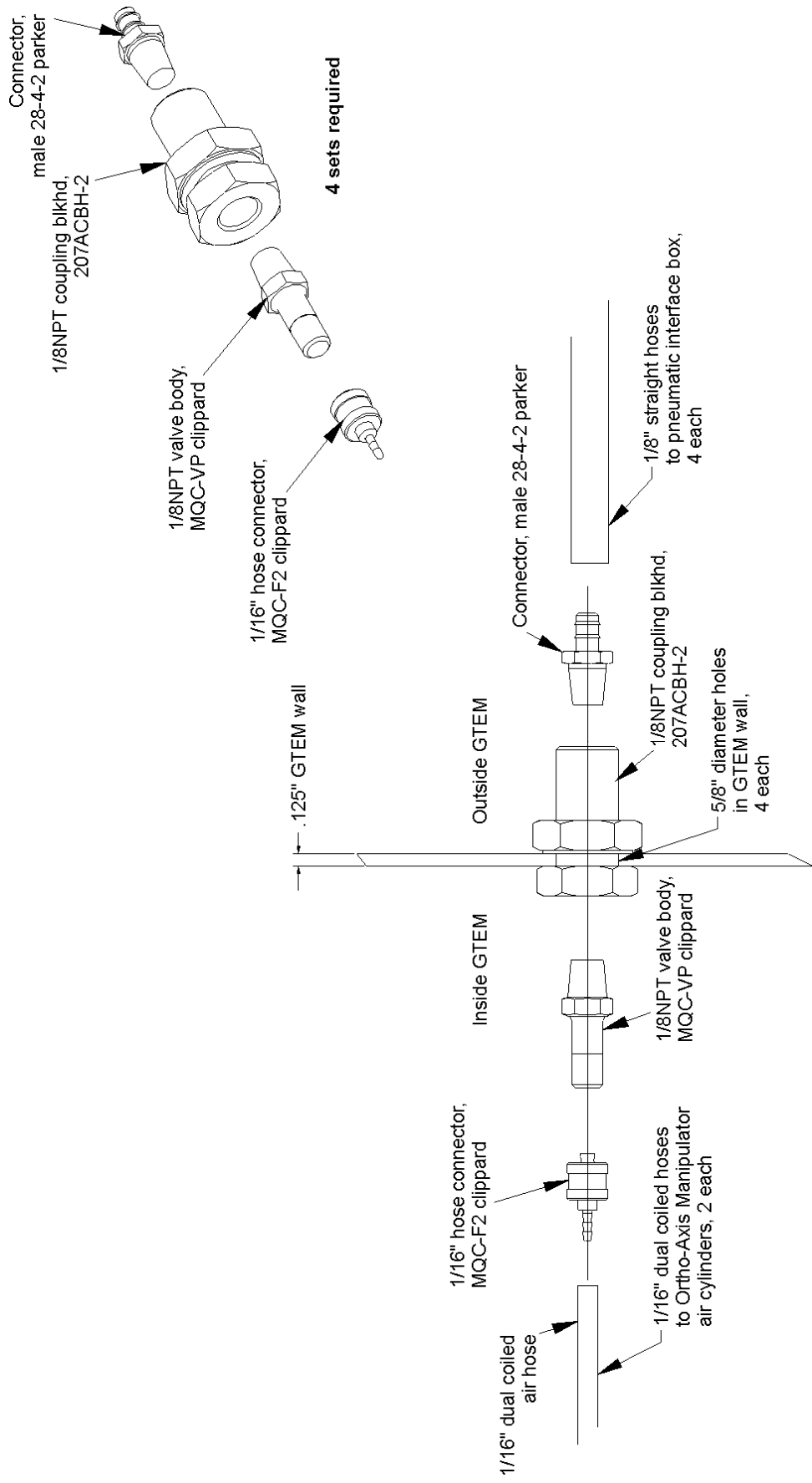

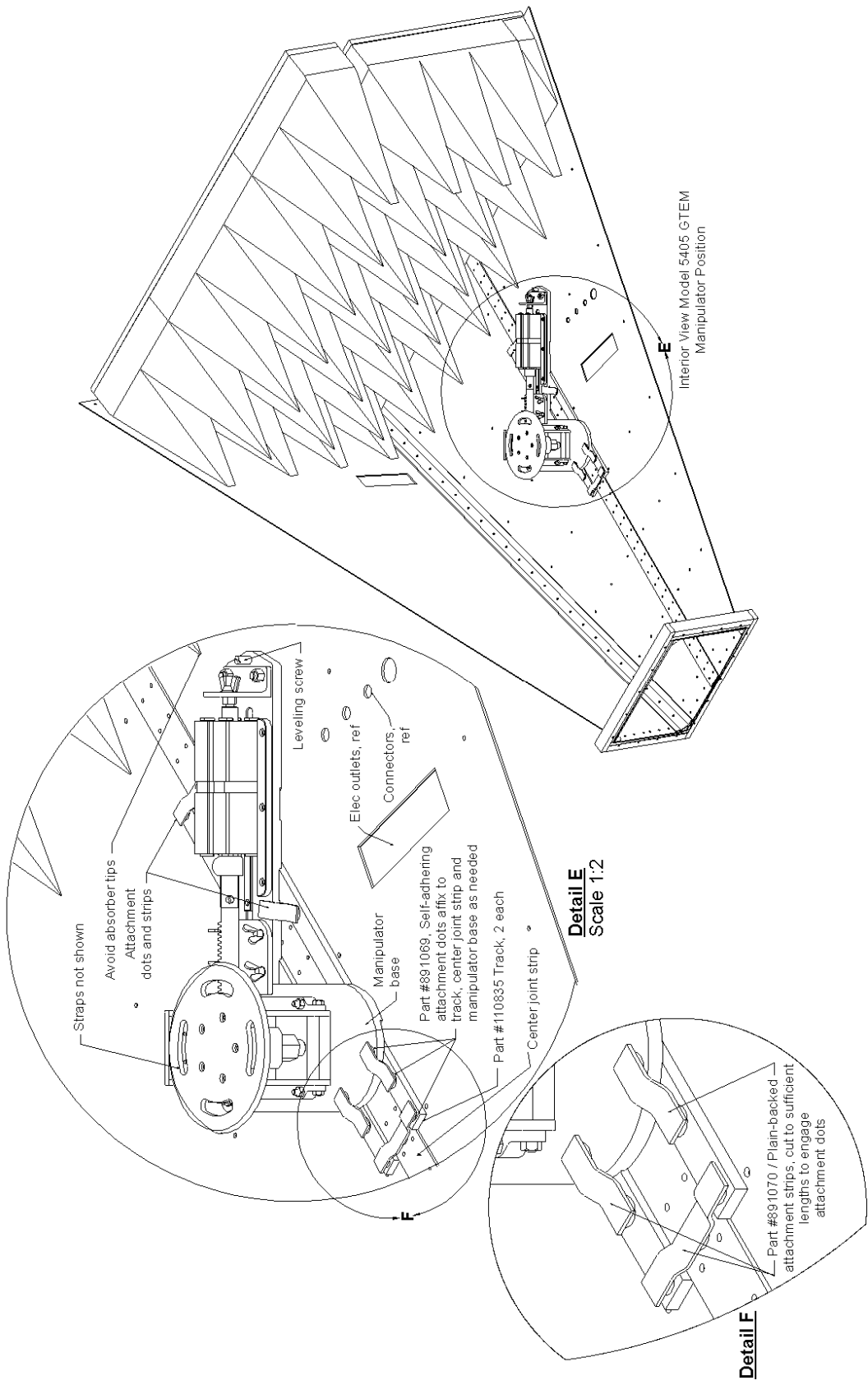

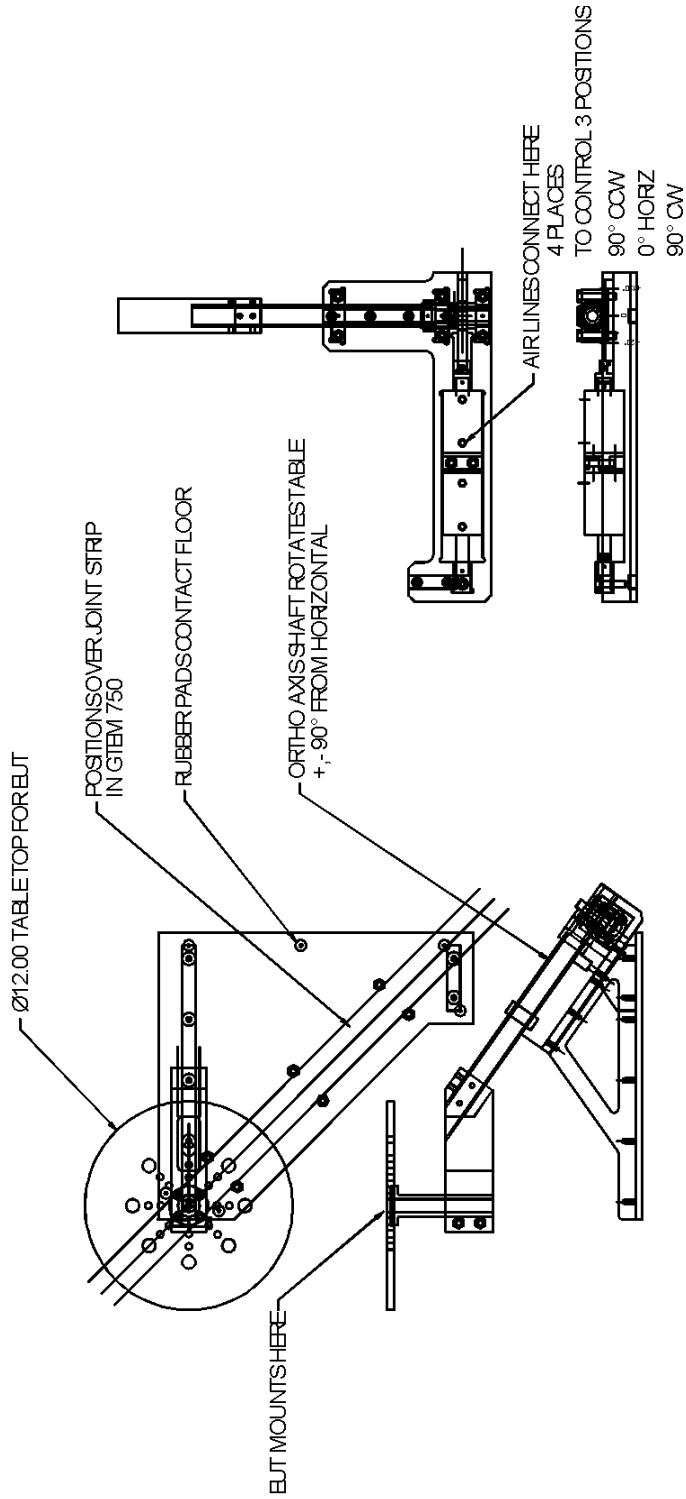

Ortho-Axis Positioner for Model 5411

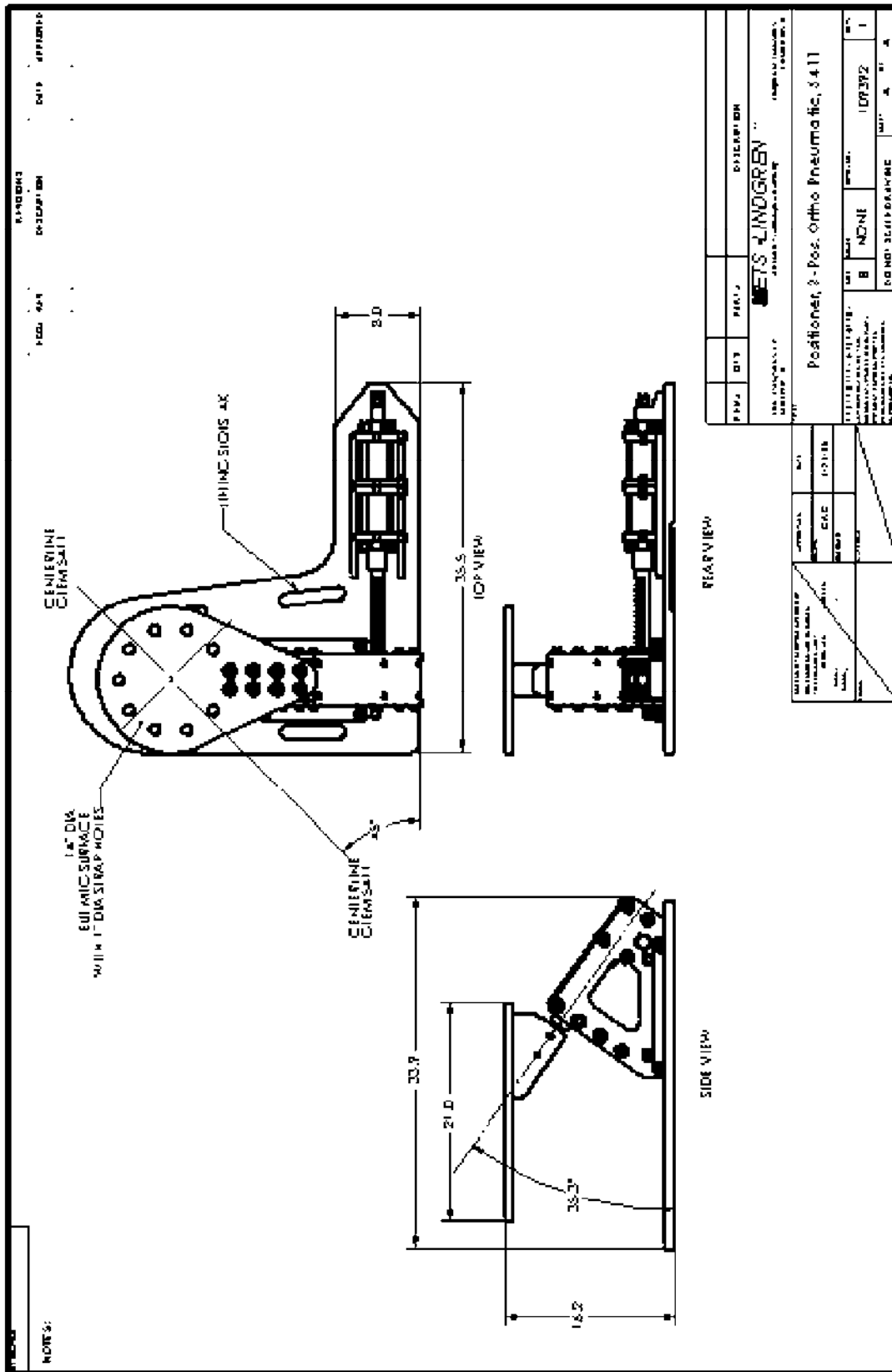

This page intentionally left blank.

8.0 GTEM! Manual EUT Manipulator (Optional)

Manual EUT manipulators are designed for use with Model 5407 and Model 5411 to aid with the accurate positioning of the Equipment Under Test (EUT). The EUT manipulator used in the Gigahertz Transverse Electromagnetic (GTEM![™]) Cell facilitates rapid testing of the EUT using not only the standard three-position test procedure, but nine, twelve, twelve-plus-four, and other test procedures that are needed to provide near-field measurements and to characterize special EUT.

Electromagnetic compatibility (EMC) measurements in the GTEM! require that the EUT be measured in at least three orthogonal positions. This is necessary to ensure that enough data is collected to predict or correlate the performance of the EUT to measurements on an Open Area Test Site (OATS) or in a semi-anechoic chamber. Whether measuring the EMI emissions or immunity of EUT, tests must be made in several positions. Positioning the EUT for each measurement can be done manually, but this can be time consuming and can require two or three people to reposition the EUT inside the GTEM!. Not only does changing the EUT position take time, but also supplies of low-permittivity dielectric materials are needed to support it in each measurement position. The time to manually position the EUT can be the major part of the total test time when nine or more positions are needed.

EUT Manipulator Platform Apparatus

The manipulator platform apparatus consists of a cradle with EUT turntable (top turntable), and a cradle support frame also with turntable (bottom turntable). Rotation is possible in three axes: the bottom turntable azimuth axis perpendicular to the floor of the GTEM!, the top turntable azimuth axis perpendicular to the bottom of the cradle, and the cradle horizontal tilt axis. The manipulator for the Model 5407 is shown in *Manual EUT Manipulator – Model 5407* on page 60. The manipulator for the Model 5411 is similar in physical appearance and is sized to fit the recommended test volume of the larger test cell. The EUT turntable includes holes for anchor points to secure the EUT during testing. The manipulator is constructed of low-permittivity wood and non-metallic fasteners to minimize perturbation of the electromagnetic fields.

This page intentionally left blank.

9.0 Manual EUT Manipulator Operation Theory

Measurements in a GTEM!

A Gigahertz Transverse Electromagnetic (GTEM!TM) Cell may either receive or transmit; thus electromagnetic interference (EMI) measurements in a GTEM! may be of either emissions or immunity. Among emissions measurements are far-field, near-field, and some special measurements. To predict the performance of the Equipment Under Test (EUT) during measurements of emissions on an Open Area Test Site (OATS), the emissions must be measured in a specific set of positions in the GTEM!. Predictive EUT performance on an OATS by making measurements in a GTEM! is also called *correlation*, and the mathematical process is often called the *correlation algorithm*.

FAR-FIELD MEASUREMENTS

Simplified far-field measurements may be made of EUT in a GTEM! to predict or correlate OATS-measured emissions. These measurements are usually made to show compliance to standards, such as CISPR 22 or FCC Part 15, in which it is only necessary to know the maximum E-field versus frequency within a specified range of heights at a certain distance. For example, FCC tests for home computers search heights from one to four meters above the ground at a distance of three meters over the frequency range of 30 MHz to 5 GHz. These simplified measurements require emissions to be measured with the EUT in only three orthogonal positions. This is called the three-measurement, three-input correlation algorithm. The main simplifying assumption in this algorithm is that the EUT has gain no greater than a dipole; for example, a dipole radiation pattern.

NEAR-FIELD MEASUREMENTS

Near-field measurements may be made of EUT in a GTEM! to correlate emissions over the frequency range of 9 kHz to 30 MHz. This is called the nine-measurement, nine-input correlation algorithm, and requires measurement of emissions with the EUT in nine positions. The EUT is assumed to be much smaller than a wavelength in the largest dimension, a reasonable assumption below 30 MHz for EUT that will fit into a GTEM!. While this algorithm was originally intended for near-field measurements below 30 MHz, it also works well for far-field measurements above 30 MHz and should be valid from 9 kHz to 5 GHz.

MANUAL EUT MANIPULATOR – MODEL 5407

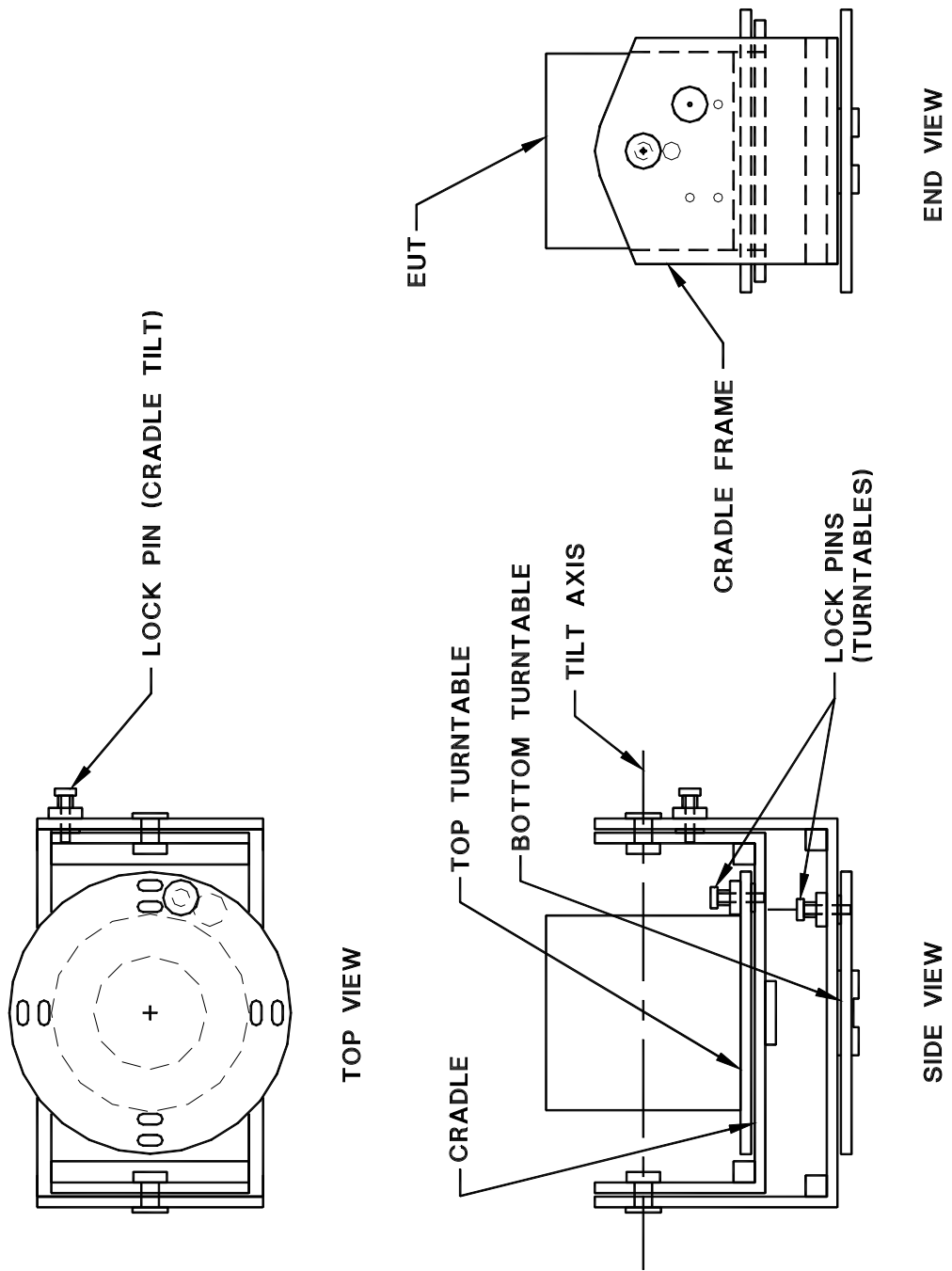

SPECIAL MEASUREMENTS

Special measurements are sometimes required because the EUT may have gain greater than a dipole, in which case the radiation pattern may be cardioid or other unidirectional pattern. Above about 500 MHz, some EUT may have an incidental unidirectional pattern because of the way they are constructed, but others have a unidirectional pattern because they are intentional transmitters with a built-in antenna. Two algorithms may be used depending on what one wants to know about the EUT. The simplest one is the 12-measurement, sorted three-input correlation algorithm, and the other one is the 12+4-position correlation algorithm. In both of these algorithms, the EUT is viewed as a cube and measurements are taken of the emission from each face in both polarizations. The 12-measurement, sorted three-input correlation is used when it is not necessary to know anything about the shape of the radiation pattern of the EUT. It is often used to test small telecom terminal equipment, such as cellular telephones, up to 10 GHz. It is valid from 30 MHz to at least 10 GHz. The 12+4-position correlation algorithm is used to estimate the shape of the radiation pattern of the EUT. It is valid from 30 MHz to 5 GHz.

IMMUNITY MEASUREMENTS

Immunity measurements may be made in the GTEM! to satisfy standards such as MIL-STD-462 or IEC 61000-4-20. If the shape of the radiation (sensitivity) pattern of the EUT is unknown, then the front, back, and both sides must all be exposed to the test signal in both horizontal and vertical polarizations. To do this, eight positions must be tested so that the four usually vertical sides of the EUT are tested in both polarizations facing the apex of the GTEM!. If the operator already knows that only one side (for example, the back) of the EUT is sensitive to external electromagnetic fields, then the testing can be reduced to exposing only the one sensitive side to the apex of the GTEM! in both polarizations.

Installing the Manipulator and EUT

Position the cradle turntable, base turntable, and cradle tilt to the 0-degree marks. For the Model 5407, place the manipulator such that the grooves straddle the center seam strip. The suggested start position is with the cradle side plates perpendicular to the center longitudinal seam, and spaced approximately 20 cm from the absorber tips. Place the EUT on the cradle turntable and secure it with non-metallic cords or rope. Polystyrene blocks may be placed under the EUT for elevation before securing. For the Model 5411, place the manipulator so that the unit is positioned approximately 20 cm from the absorber tips. Center the manipulator along the longitudinal axis of the GTEM!. Rubber feet will help maintain the position during testing.

Naming the EUT Faces

For the purpose of this discussion, consider the EUT as a cube. The following illustrates a three-dimensional Cartesian coordinate system with a cube centered on it. The face from which a positive axis emerges is named for that axis; for example, **+X** is the face of the cube from which the positive X-axis emerges. Name the front of the EUT **-Z** and the back **+Z**. Looking at the **+Z** face (the back), name the right side **+Z** and the left side **-X**. Name the top **+Y** and the bottom **-Y**.

EUT AS A CUBE ON CARTESIAN AXES SHOWING NAMES OF FACES

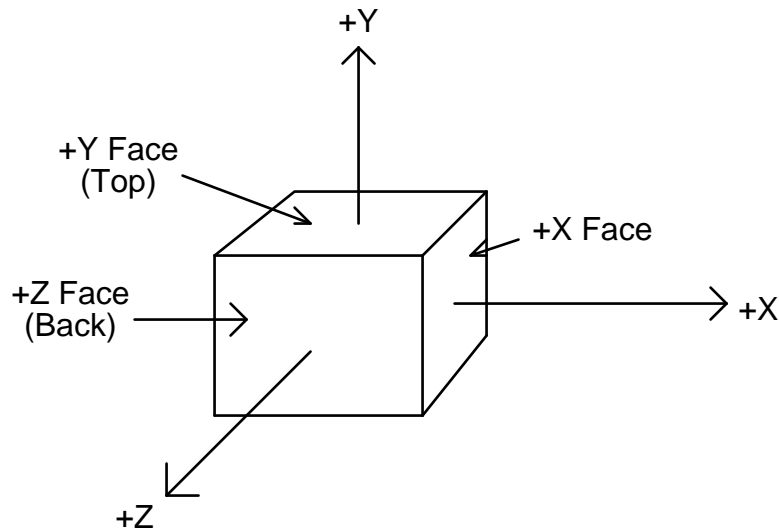

This is the coordinate system for the EUT. Note that the three orthogonal positions of the EUT exchange the EUT coordinates relative to the GTEM! coordinates. The first position is identified as **XYZ**, the second as **YZX**, and the third as **ZXY**; the voltages measured at the apex of the GTEM! in the three positions are called **V_{xyz}**, **V_{yzx}**, and **V_{zxy}**.

EUT Positions

Emissions tests all require sets of positions, which are built on the basic three orthogonal positions needed by the three-measurement, three-input correlation. Immunity tests require positions based on the test standard; these are not necessarily extensions of the basic set of three orthogonal positions.

Sets of Positions Needed

For the three-measurement, three-input correlation, any set of three orthogonal positions can be used. A typical rotation series is as follows.

For the Model 5400 Series with the door on the right side (looking from the apex), position the manipulator with the 0-degree mark pointing toward the right side of the door. Secure the EUT to the top turntable.

See *Manual EUT Manipulator Positions for Three-Position Emissions Test – Model 5400 Series* on page 64 for these steps:

- **a**—Shows a schematic of this arrangement as seen looking in the door. This is the first test position used to measure V_{xyz} .
- **b**—Release the cradle tilt lock pin and swing the cradle away from the door to the 90-degree tilt position. The EUT x-axis now points down, as shown.
- **c**—Rotate the top turntable to 90-degrees (as shown), and measure V_{yzx} .
- **d**—Rotate the top turntable to the 180-degree position.
- **e**—Rotate the bottom turntable to 90-degrees and measure V_{zxy} .

**MANUAL EUT MANIPULATOR POSITIONS FOR THREE-POSITION
EMISSIONS TEST – MODEL 5400 SERIES**

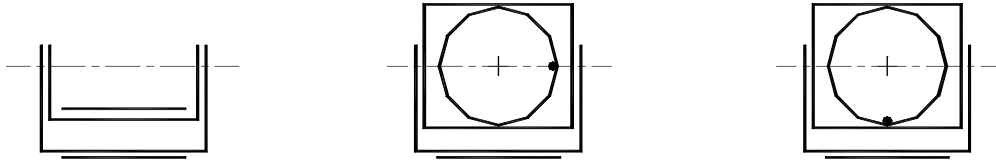

V_{xyz}

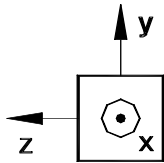

a.

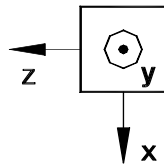

b.

V_{yzx}

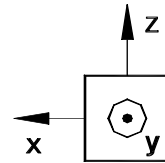

c.

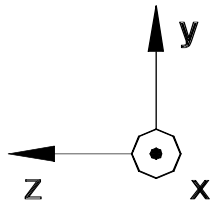

**GTEM AXES
ALL POSITIONS**

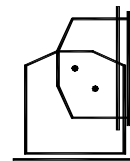
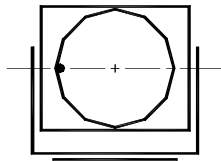

V_{zxy}

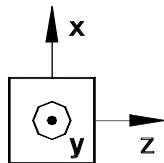

d.

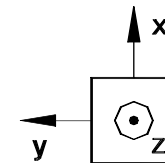

e.

For the nine-measurement, nine-input correlation, at each of the measurement positions shown in figures x, x, and x, rotate the bottom turntable ± 45 degrees and take additional voltage readings. For the 12-measurement, sorted three-input correlation, and for the 12+4 position correlation, contact the factory for the suggested mini-manipulator positioning. The 12-measurement, sorted three-input correlation eliminates the assumption of gain no greater than a dipole, and can be used to do tests in which the power at the dipole terminals need to produce the same emission level measured from the EUT. The 12+4 position correlation estimates the directivity, and thus the gain of the EUT, then uses this estimated gain in the three-measurement, three-input correlation.

This page intentionally left blank.

Appendix A: Warranty



See the *Product Information Bulletin* included with your shipment for the complete ETS-Lindgren warranty.

DURATION OF WARRANTIES

All product warranties, except the warranty of title, and all remedies for warranty failures are limited to two years.

Product Warranted	Duration of Warranty Period
Model 5400 Series Gigahertz Transverse Electromagnetic (GTEM! TM) Cell	2 Years

This page intentionally left blank.

Appendix B: Emission Measurements in TEM Cells and TEM Lines

Multipole Model

Any finite-sized radiation source may be replaced by an equivalent multipole expansion that gives the same radiation pattern outside some volume bounding the source. If the source is electrically small, then the initial multipole moments, electric and magnetic dipoles, will yield an accurate representation. This holds for an arbitrary source. If the source itself consists of electric and magnetic dipole like elements only, then the electrically small restriction may be relaxed.

The basic approach of transverse electromagnetic mode (TEM) cell or TEM line to Open Area Test Site (OATS) correlation routines is to use a set TEM cell measurement to determine the multipole moments. Once the multipole moments are known, radiation either in free space or over an infinite ground plane may be simulated numerically. In this way it is possible to simulate the various source-to-receiver antenna configurations required by OATS emission standards.

For two-port TEM cells or TEM lines, measurements at both ports yield amplitude and relative phase information. In this way both the magnitude and phase of the multipole moments may be determined and the radiation pattern accurately simulated, including possible nulls due to phase cancellation. For one-port TEM cells or TEM lines no relative phase information is available; therefore, it is only possible to determine the magnitudes of the multipole moments. Such a representation well simulates emission maximums, which are of primary interest in electromagnetic compatibility (EMC) measurements; however, radiation pattern nulls may not be well simulated.

Two-Port TEM Cell or TEM Line Correlation Routine

See *References* on page 91.

One-Port TEM Cell Correlation Routine

The most time-efficient one-port correlation routine is based on the assumption that the Equipment Under Test (EUT) may be reasonably represented by the initial multipole moments, namely the electric and magnetic dipole moments. Three voltage measurements are then made in a TEM cell from which the EUT total radiated power may be calculated. The individual dipole moments are not separately determined. The total radiated power is then used to simulate the maximum EUT fields over a ground plane based on a model of parallel dipoles, either horizontal or vertical, radiating the same total power.

TEM CELL VOLTAGE MEASUREMENTS: THREE POSITIONS

The EUT emissions are measured in three positions that are determined as follows:

Assign an axis system (x, y, z) to the TEM cell and to the EUT. A standard choice is to align the z -axis in the direction of propagation, the y -axis with the E-field (vertical), and the x -axis with the H-field. A local coordinate primed system is assigned to the EUT. Position one aligns x with x' , y with y' , and z with z' . Position two is obtained by simply permuting the primed EUT axes. This is equivalent to two 90-degree rotations of the EUT. Position three is obtained by further permutation. Denoting the three voltage measurements by V_1, V_2, V_3 , it may be shown that the total radiated power due to EUT is then given by the equation.

EUT emissions over a ground screen are simulated by assuming the same total radiated power is emitted by a short dipole (replacing the EUT). The equations for the fields from a dipole are well known and the ground screen may be accounted for by introducing an image dipole. The fields may be calculated over the equivalent sweep path of receiving antenna if required and the maximum determined for both polarizations. The maximum for the two polarizations would then give the maximum possible field. The geometry factor due to sweeping the observation point is designated as f , and the maximum field E is given by the equation.

Appendix C: Radiated Emissions Test Performance of GTEM!

ABSTRACT

The Gigahertz Transverse Electromagnetic (GTEM!TM) Cell has recently been recognized as a competing technology for the accomplishment of electromagnetic compatibility (EMC) radiated emissions testing for the demonstration of compliance with commercial specifications. As a competing technology, the direct comparison of the performance of the GTEM! for such compliance measurements to the results obtained from an Open Area Test Site (OATS), is an obvious and necessary step. This section describes the direct comparison of results of two series of tests. Two differing comparisons are described; three separate sets of reference dipole comparison measurements, and two full personal computer systems tested per the requirements of ANSI 63.4, Draft 11.4 on an OATS and in the GTEM!. In addition to a direct comparison, the resultant data has also been subjected to statistical analysis. The statistical analysis was performed on maximum electric field strength data comparing GTEM! calculated levels with OATS measured levels. Pearson's correlation coefficient and Student's-t distribution were used to analyze data. Good agreement of results, both by direct comparison and by the statistical analysis have been found, and are described.

INTRODUCTION

The GTEM! as shown on page 72 has existed in conceptual form and as a practical device for some time. Only recently has the use of this device, as an alternative to radiated emissions measurements on an OATS, been as a practical choice. This change has been brought about by additional developments of the theory of this device, such that a direct comparison can be made to the results obtained from an OATS. The main contribution that has brought forward the GTEM! as a practical radiated emissions device has been in the theoretical development of a mathematical model allowing the direct comparison of data taken in a GTEM! to data acquired on an OATS. The software implementation for the GTEM! accomplishes the following, given three voltage versus frequency measurements for three orthogonal orientations of the Equipment Under Test (EUT) in the GTEM!.

At each frequency:

- Performs a vector summation of the three orthogonal voltages
- Computes the total power emitted by the EUT as determined from the summation of the three voltages and the transverse electromagnetic mode (TEM) equations for the GTEM!

- Computes the current excitation of an equivalent tuned, resonant dipole when excited with that input power
- Computes the field intensity at appropriate height intervals over the total scan height, either 1 to 4 meters or 2 to 6 meters for both vertical and horizontal polarizations of the receive antenna when the equivalent tuned resonant dipole is placed at an appropriate height over a perfect ground plane
- Selects the maximum field strength (larger) value of the horizontal or vertical polarizations
- Presents this maximum value as compared to the chosen EMC specification limit.

MODEL 5305 WITH RADIATED EMISSIONS TESTING EQUIPMENT

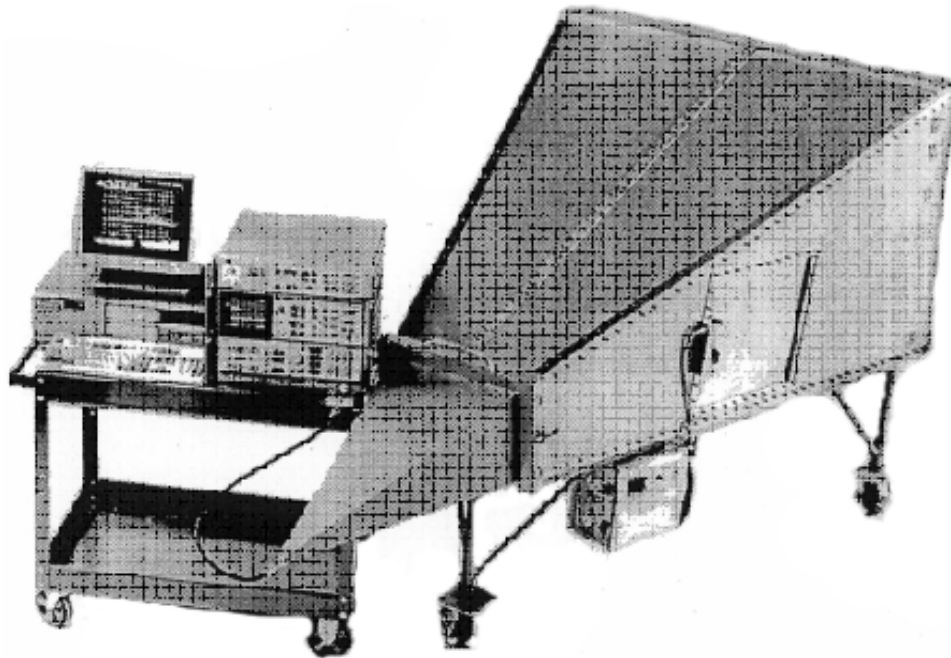

The augmentation of the GTEM! (which presents many of the advantages of both semi-anechoic chambers and traditional TEM cells without accompanying disadvantages) by sophisticated software is a significant technical advancement. This allows the direct comparison of test results from radiated emissions testing in the GTEM! to test results from more traditional test methods.

Goals of Testing and Analysis

The purpose of these tests was to develop a valid, direct comparison of the performance of the GTEM! to the performance of the OATS. The goals of testing were:

- Provide directly comparable sets of high quality test data from the GTEM! and the OATS
- Develop a simple, direct comparison of the results of these diverse tests
- Provide analytical result of the difference in the GTEM! and OATS performance that is capable of being succinctly stated, yet remains complete
- Provide a supplement to the direct comparison by a statistical analysis that provides a more sophisticated and meaningful comparison of the measurements
- Provide a statistical measure of quality of the compared measurements other than a direct statement of difference of the measurements.

Design of Testing

The development of the specific test approaches was based on the requirements of ANSI 63.4. Since this document will, in time, become the test requirements document for commercial EMC testing in the United States, it was selected as the basis for testing.

GENERAL

ANSI 63.4 provides a provision for the development of data for the qualification of alternate test sites. While this requirement is directed to the qualification of semi-anechoic chambers for radiated emissions testing, it was felt that there were technical features in this approach usable for GTEM! comparison measurements. ANSI 63.4 requires the development of normalized site attenuation data, in both vertical and horizontal polarizations, from a number of specified locations on the included turntable at the EUT location in the semi-anechoic chamber. In the ANSI documents, these measurements are made with broadband antennas such as biconical and log periodic antennas.

A test object produces a certain amount of radiated energy. Some of this energy may be directed up or down depending on the sources of radiation and the coupling among the cables interconnecting the personal computer system components. In customary traditional EMI tests on OATS, individual units and cables are moved to try to cause as much of the energy as possible to be radiated at the height around the computer such that it can be picked up in the height scan of the measurement antenna, 1 to 4 meters.

In the GTEM!, three orientations of the test object are needed, so that all three components of the total radiation vector can be picked up. It was hypothesized that the GTEM! should predict the maximum field strength that could be measured on an OATS since it picks up the total radiation vector from the test object.

To accommodate the size of the planned EUT, a Model 5317 was used. The external dimensions of this device are provided in the following illustration.

MODEL 5317 DIMENSIONS

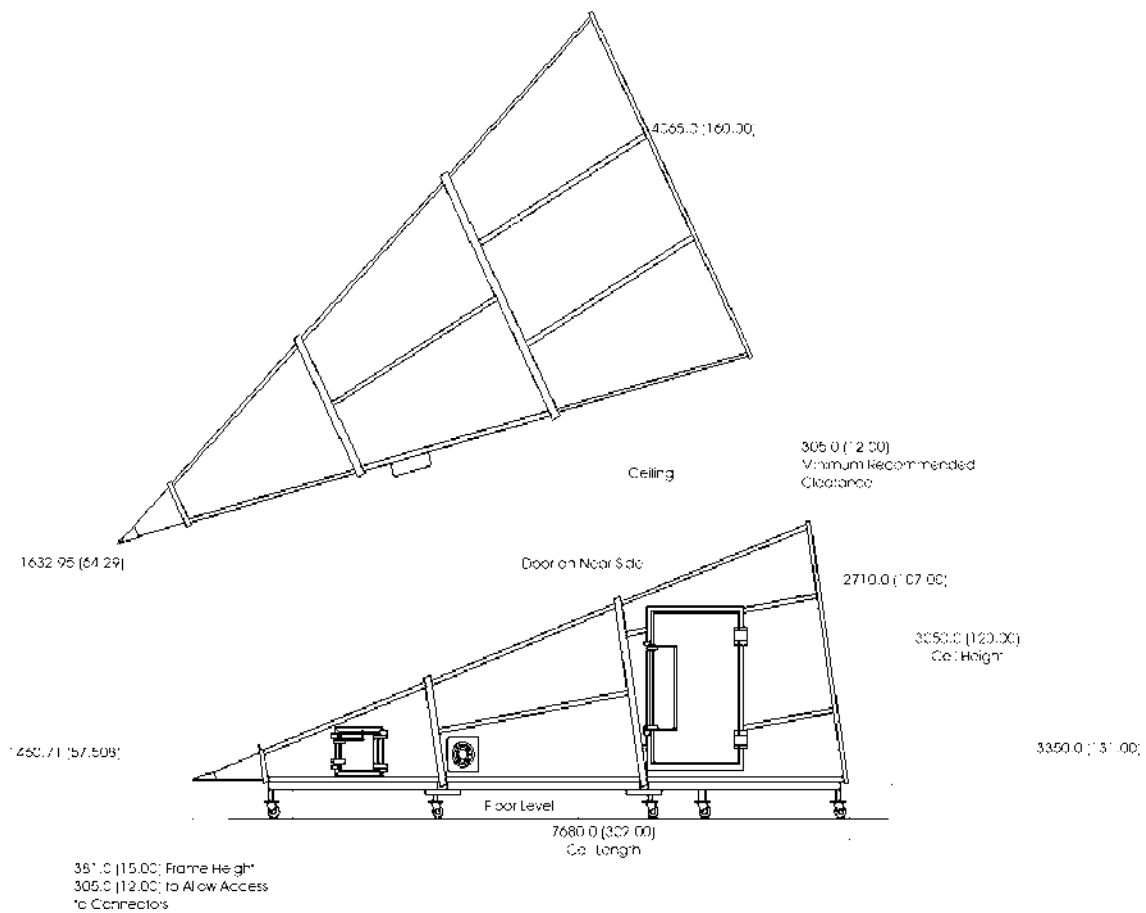

REFERENCE DIPOLE ANTENNA TESTING

Equivalence testing for GTEM! was planned using tunable dipole antennas. The tunable antennas can remain comparatively small over the majority of the frequency range of interest, and dipole antennas are the reference antennas constructed as described in ASNI 63.5, preferred for the resolution of conflicting measurements. The dipoles can be easily placed in the center of the test volume and three orthogonal measurements made to satisfy the requirements for GTEM! testing. They are also easily transferred to the OATS for the comparison testing. When the dipole antennas begin to become large with respect to the size of the GTEM! test volume, they were used as short dipoles with the dipole elements set to a fixed frequency compatible with the size of the test volume.

The resonant dipoles were installed on an OATS with the feed point of the dipole directly over the center of the turntable. The dipole was driven at many frequencies, as appropriate, to 1000 MHz. The test procedure of ANSI 63.4, was used. This procedure requires that the measurement be made at the maximum of the emanation at each frequency. This in turn requires searching the receive antenna in height, and rotation of the turntable to establish the maximum value of the emanation. Measured values were corrected to field strength values by adding cable loss and antenna factors.

The resonant dipoles were then transferred to the test volume of the GTEM!. Voltage measurements were made in three orthogonal orientations, and test control software was used to process the three orthogonal measurements into field strength versus frequency data. These values are directly comparable to those taken at the OATS.

PERSONAL COMPUTER TESTING

The second test series involved comparison testing of two different small, desktop personal computer systems. They were installed, secured to a piece of plywood with the subsystem components and interconnecting cables strapped to the plywood with nylon strapping. The strapping was firm since the entire EUT installation would be rotated to allow three orthogonal axes voltage measurements. Each personal computer system consisted of a system unit, monitor, keyboard, parallel device (printer), mouse, and serial device (printer or modem). These items were installed as shown in the figures distributed in ANSI 63.4. These figures require the installation of the EUT on a 1-m x 1.5-m table. In the testing described in this paper a 1-m x 1.5-m piece of 12-mm plywood was used. The system unit was installed with the back end of the chassis aligned with the back edge of the plywood base and centered. The monitor was centered on the system unit. The printer (required parallel peripheral) was installed to the right of the system unit at a distance of 10 cm. The modem (required serial peripheral) was installed 10 cm to the left of the system unit. The back edges of all of these units were aligned with the back edge of the plywood. The keyboard was centered and aligned with the front edge of the plywood. The mouse was installed 10 cm from the right edge of the keyboard and aligned with the back of the keyboard. All items were secured to the plywood. The plywood array was then transferred into the test volume of the GTEM! used for this testing.

The three orthogonal measurement alignments are illustrated as indicated here:

- *Personal Computer System Installed for V_{xyz} Measurement as Seen From Apex on page 77*—shows the orientation for V testing
- *Personal Computer System Installed for V_{yzx} Measurement as Seen From Apex on page 78*—shows the orientation for V testing
- *Personal Computer System Installed for V_{zxy} Measurement as Seen From Apex on page 79*—shows the orientation of V testing

The relative position of the subsystem components is shown in each illustration. Also shown are the calculated field uniformity contours for 1 dB, 2 dB, 3 dB, and 4 dB referenced to the center of the test volume. The illustrations are oriented as viewed from the apex of the GTEM!. To maximize the measured emissions values, the draping of the cable from the first position measured was preserved for a minimum of 30 cm from the back edge of the table.

PERSONAL COMPUTER SYSTEM INSTALLED FOR V_{xyz} MEASUREMENT AS SEEN FROM
APEX

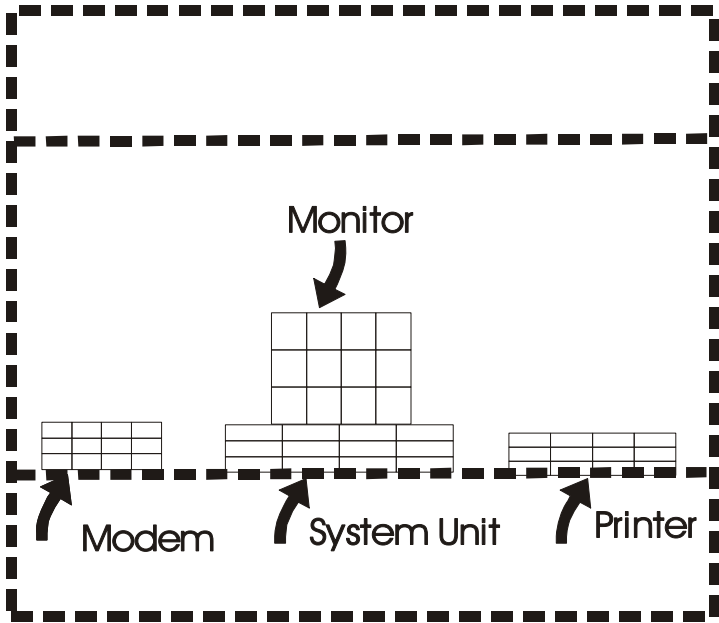

PERSONAL COMPUTER SYSTEM INSTALLED FOR V_{YZX} MEASUREMENT AS SEEN FROM APEX

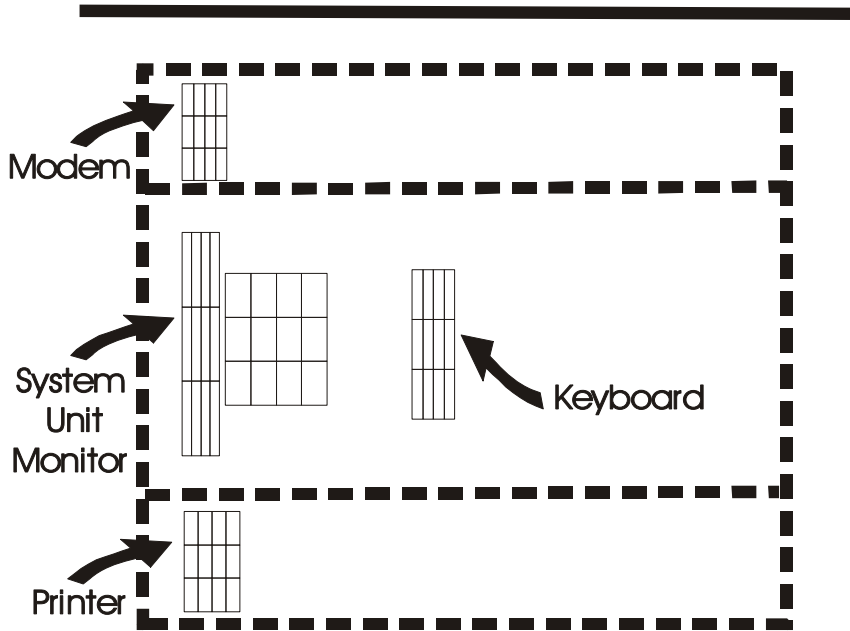

After testing in a GTEM! the plywood sheet with the EUT secured to the sheet was transferred to the OATS for comparison testing. The five highest frequencies detected in the GTEM!, from each PC array, were evaluated at the OATS using the procedures of ANSI 63.4.

PERSONAL COMPUTER SYSTEM INSTALLED FOR V_{ZXY} MEASUREMENT AS SEEN FROM APEX

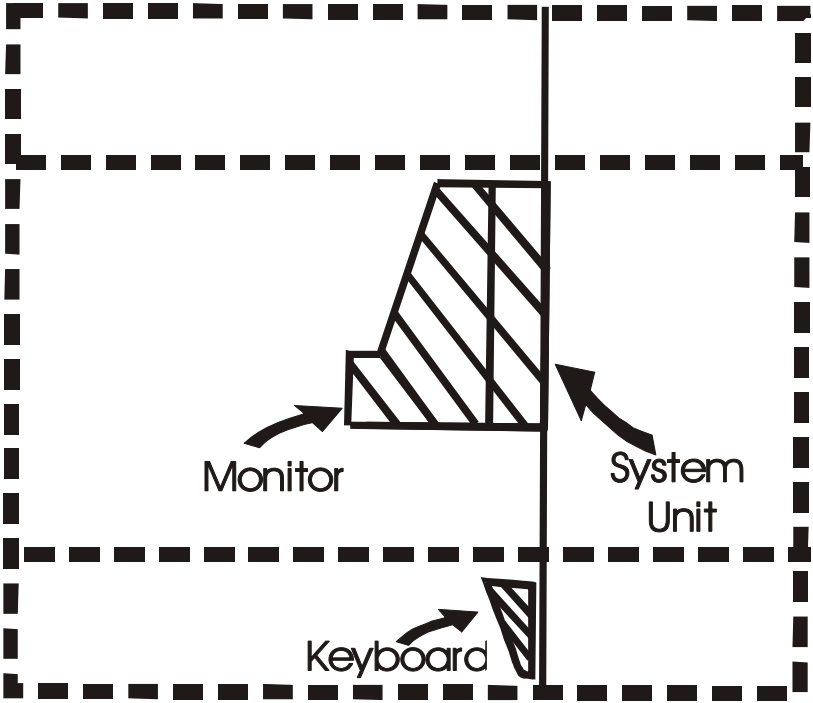

Design of Data Analysis

The consideration of how to compare the data between the two types of test facilities, the GTEM! and an OATS, is less straightforward than may seem. Two types of analysis of the comparative data were performed: direct and statistical comparisons.

DIRECT COMPARISONS

The first comparison of the data is the direct subtraction of the OATS measurement of a signal at any frequency from the GTEM! measurement at the same frequency. This gives a quantitative analysis of the direct difference of the measurements. By subtracting the OATS reading from the GTEM! reading, a positive value indicated that the GTEM! measured signal is larger than the OATS measured signal. Conversely, a negative value indicates that the GTEM! is measuring the emanation lower than the OATS.

The second direct comparison of the data is the determination of the mean and standard deviation at the differences for all data points in a single data set.

STATISTICAL COMPARISONS

- **Pearson's Correlation Coefficient**—Pearson's correlation coefficient and linear regression equation coefficients were calculated for data (the first three sets of dipole data and the first two sets of personal computer data) in which values from different distances were combined for overall evaluation. The correlation helps to show when the data is not independent and can properly be combined for further analysis.
- **Meaning of the Value of Pearson's Correlation Coefficient**—Values of Pearson's correlation coefficient between +0.6 and +1, and regression line slopes between +0.05 and +1.5 indicate a strong relationship between the samples of data.
- **Student's-t Statistic**—Student's-t statistic for paired, sample variables was used to analyze the comparison data for both the dipoles and the personal computers. This approach allowed testing the null hypothesis for the difference between the GTEM! data and the OATS data.

- **Meaning of Student's-t Statistic**—The interval of Student's-t distribution between $-t$ and $+t$ represents a region in which with a specific probability, all sets of samples of data are from the same population, and therefore are the same even though their means and sample variances appear to be different. The hypothesis that the sample mean is no different than the population mean is called the null hypothesis, H_0 , and it is accepted or rejected by virtue of whether the sample mean lies within the interval of $-t$ and $+t$. The confidence that the sample mean and the population mean are the same is 100 (1- α) percent. If T lies outside of the interval $-t$ to $+t$, the null hypothesis must be rejected.

Student's-t statistic is tabulated for various degrees of freedom (d.f.). The tabulation must be entered with the d.f. and the confidence level to find the limits of the interval to be used. For paired, related data, the d.f. are one less than the number of pairs of data; and for paired independent data, the d.f. are one less than the sum of the number in each set of sample data.

Student's-t statistic for non-independent (related) paired sample variables was used for the first two sets of personal computer data since the same test object and configuration were used for measurements both in the GTEM! and the OATS.

Student's-t Statistic for independent paired sample variables was used for the first three sets of dipole data, since a different signal generator was used on the OATS from that used in the GTEM! measurement.

TEST SERIES 1 – DIPOLE TESTING

A series of three tuned dipole measurements were accomplished under slightly different circumstances. The three sets of measurements are as follows:

A set of measurements were performed using only tuned resonant dipoles covering the frequency range of 500 MHz to 1000 MHz. The measurements were conducted at three distances, 3, 10, and 30 meters, corresponding to the three measurement distances common in international commercial EMC specifications. The measurements were made in a GTEM! and the field strength calculation was performed at the three measurement distances. The same dipoles were then transferred to the OATS and comparison measurements performed. The results of these measurements are shown in the following tables.

Table 1: Tune Resonant Dipole Measurements at 3 Meters

The average difference between the GTEM! and the OATS is -1.97 dB, and the standard deviation is 1.39 dB.

Frequency (MHz)	GTEM! Computed Field Strength (dB uV/m)	OATS Measured Field Data (dB uV/m)	Difference (dB)
500.0	92.6	93.4	-0.8
600.0	92.3	93.7	-1.4
700.0	91.5	94.2	-2.7
800.0	90.4	92.2	-1.8
900.0	92.3	92.8	-0.5
1000.0	92.2	90.9	+1.4

Table 2: Tune Resonant Dipole Measurements at 10 Meters

The average difference between the GTEM! and the OATS is -1.2 dB, and the standard deviation is 1.26 dB.

Frequency (MHz)	GTEM! Computed Field Strength (dB uV/m)	OATS Measured Field Data (dB uV/m)	Difference (dB)
500.0	83.7	83.2	+0.5
600.0	82.1	83.6	-1.5
700.0	81.9	84.4	-2.5
800.0	80.6	82.2	-1.6
900.0	82.5	84.8	-2.3
1000.0	84.1	83.9	+0.2

Table 3: Tune Resonant Dipole Measurements at 30 Meters

The average difference between the GTEM! and the OATS is -0.25 dB, and the standard deviation is 1.27 dB.

Frequency (MHz)	GTEM! Computed Field Strength (dB uV/m)	OATS Measured Field Data (dB uV/m)	Difference (dB)
500.0	83.7	83.2	+0.5
600.0	82.1	83.6	-1.5
700.0	81.9	84.4	-2.5
800.0	80.6	82.2	-1.6
900.0	82.5	84.8	-2.3
1000.0	84.1	83.9	+0.2

Table 4: Resonant Dipole Data, GTEM! versus OATS at 3 Meters

The second set of dipole measurements were made over the frequency range of 400 MHz to 1000 MHz. Tuned resonant dipoles were used for this testing.

The average difference between the GTEM! and the OATS is +1.21 dB and the standard deviation is 1.52 dB.

Frequency (MHz)	GTEM! Computed Field Strength (dB uV/m)	OATS Measured Field Data (dB uV/m)	Difference (dB)
400.0	93.5	93.7	+0.2
500.0	93.7	92.9	-0.8
600.0	91.1	93.0	+1.9
700.0	89.8	92.2	+2.4
800.0	92.5	92.3	-0.20
900.0	90.3	93.7	+3.4
1000.0	90.3	91.9	+1.6

Table 5: Resonant Dipole Data, GTEM! versus OATS at 3 Meters

The third dipole test was performed in the same manner as the first, with the exception that an extended frequency range of the evaluation was desired. Where only resonant dipoles were used in the first evaluations, short dipoles were added to allow the extension of the evaluation down to 50 MHz. Tuning the resonant dipole to 230 MHz and lowering the frequency of excitation in steps to 50 MHz accomplished this. The dipoles were tuned to resonance at 230 MHz and above. The data is summarized in the following table. Note that the data was acquired with different instrumentation at different test sites using a different GTEM!, resulting in an independent set of data.

The average difference between the GTEM! and the OATS is -1.62 dB and the standard deviation is 2.68 dB.

Frequency (MHz)	GTEM! Computed Field Strength (dB uV/m)	OATS Measured Field Data (dB uV/m)	Difference (dB)
50.0	45.8	45.0	-0.8
100.0	69.3	73.1	+3.8
200.0	88.5	84.4	-4.1
230.0	96.0	88.7	+7.7
250.0	92.7	91.9	-0.8
300.0	99.8	97.3	-2.5
400.0	100.3	100.5	+0.2
500.0	101.3	100.7	-0.6
600.0	98.3	98.1	-0.2
700.0	99.7	96.7	-2.9
800.0	99.8	99.5	-0.3
900.0	100.2	97.3	-2.9
1000.0	99.6	97.3	-2.3

PERSONAL COMPUTER TESTING

Test results for the testing of the two personal computer systems are shown in the following tables.

Table 6: Personal Computer System 1, OATS versus GTEM! at 3 Meters

The average difference between the GTEM! and the OATS is +3.18 dB and the standard deviation is 3.85 dB.

Frequency (MHz)	GTEM! Computed Field Strength (dB uV/m)	OATS Measured Field Data (dB uV/m)	Difference (dB)
35.32	64.4	63.6	+0.8
70.65	62.1	54.0	+8.1
141.5	45.2	45.2	+0.0
160.5	46.1	45.7	+0.4
186.1	45.0	38.4	+6.6

Table 7: Personal Computer System 1, OATS versus GTEM! at 10 Meters

The average difference between the GTEM! and the OATS is 2.18 dB and the standard deviation is 4.57 dB.

Frequency (MHz)	GTEM! Computed Field Strength (dB uV/m)	OATS Measured Field Data (dB uV/m)	Difference (dB)
35.33	54.4	57.7	-3.3
70.6	52.1	42.8	+9.3
141.6	35.2	34.2	+1.0
160.5	36.1	35.0	+1.1
186.1	35.0	32.2	-2.8

Table 8: Personal Computer System 2, OATS versus GTEM! at 3 Meters

The average difference between the GTEM! and the OATS is -0.19 dB and the standard deviation is 2.10 dB.

Frequency (MHz)	GTEM! Computed Field Strength (dB uV/m)	OATS Measured Field Data (dB uV/m)	Difference (dB)
140.0	28.74	27.5	+1.24
182.0	26.00	28.0	-2.00
185.0	30.20	28.6	+1.60
233.0	28.91	27.8	+1.11
320.0	24.69	27.6	-2.91

The data is summarized in *Table 9* and *Table 10* in the next section. Note that this data was acquired with different instrumentation at different test sites using a different GTEM!, therefore producing an independent set of data.

Discussion of Test Results

This section describes the results of the analysis performed on the data, and provides commentary about the results.

RESULTS OF COMPARATIVE ANALYSIS

The test series reported show good agreement between GTEM! measurements and OATS measurements. It is interesting to note that the sets of dipole measurements summarized in the following table show reasonably consistent results.

Table 9: Summary of Dipole Measurements

Data Set	Average Difference (dB)	Standard Deviation (dB)
Dipole Data 1 at 3 Meters	-0.97	1.39
Dipole Data 1 at 10 Meters	-1.20	1.26
Dipole Data 1 at 30 Meters	-0.25	1.27
Dipole Data 2 at 3 Meters	-1.21	1.52
Dipole Data 3 at 3 Meters	+1.59	2.6

Table 11 on page 88 shows Pearson's correlation coefficient and the regression coefficients for the first three sets of dipole measurements and the first two sets of personal computer measurements. The correlation is good enough, though while these results came from measurements in which certain parts of the process were different, they can be combined with the rest of the data for further analysis.

A similar summary for the personal computer data is shown in the following table.

Table 10: Summary of Personal Computer Measurements

Data Set	Average Difference (dB)	Standard Deviation (dB)
PC 1 at 3 Meters	3.18	3.85
PC 1 at 10 Meters	2.18	4.57
PC 2 at 3 Meters	0.19	2.09

The personal computer data is again on reasonably good agreement between the GTEM! and the OATS measurements. There is a difference between the first two data sets and the third that is in part attributable to the improvement in test procedures as the learning curve flattened. The last data set is felt to be representative of the measurement capability of the GTEM! much more than the first two.

As can be seen by comparing the data between Table 9 and Table 10, there is a larger deviation in personal computer data and dipole data. This is thought to be related to the difference in the type of EUT from dipoles to a personal computer system. Dipoles are strongly polarized in that the two planes that are orthogonal to the plane of polarization show radiated emission levels that are low with respect to the primary plane. The personal computer system shows much smaller differences in the three orthogonal measurements. It is suspected that this difference as related to the characteristic of the personal computer array to radiate more equally in three orthogonal directions.

RESULTS OF STATISTICAL ANALYSIS

The general results of the statistical analysis are shown in the following tables.

Table 11: Correlation of Data from the First Three Dipole Measurements and the First Two Personal Computer Measurements

Coefficient	Dipole I (Tables 1, 2, 3)	PC 1 (Tables 4 & 5)
R	0.941	0.988
a	-2.36	+3.30
b	+1.00	0.95

The next table illustrates the results of the Student's-t comparisons between the several sets of data and the null hypothesis test. D is the standard mean difference of the data sets, SD is the standard deviation of the mean differences, t is the interval from the Student's-t distribution for a 95% confidence, and T is the deviation of the difference of the sample means from zero normalized to Student's-t distribution.

Table 12: Summary of Statistical Analysis on All Measurements
 $<\alpha=0.05, H_0: \mu_D=0>$

Data Set	Dipole 1 (Tables 1, 2, 3)	Dipole 2 (Table 4)	Dipole 3 (Table 5)	PC 1 (Tables 6 & 7)	PC 2 (Table 8)	All Dipoles	All PCs	All Data
D	-0.8	+1.2	-1.6	+2.7	-0.2	-0.7	+1.7	-0.02
S_p	2.7	2.3	7.2	4.0	4.4	4.5	13.6	8.1
n	36	7	13	10	5	38	15	53
d, f	34	6	12	9	4	37	14	52
t	+/-2.030	+/-2.447	+/-2.179	+/-2.262	+/-2.776	+/-2.029	+/-2.145	+/-2.008
T	-0.295	+1.388	-0.812	+2.107	-0.097	-0.980	+0.489	-0.022
H_0	Accept	Accept	Accept	Accept	Accept	Accept	Accept	Accept

SUMMARY OF STATISTICAL FINDINGS

The results show that there is no significant difference between the samples data and we can accept the null hypothesis. That is, the GTEM! measurement is the same as the OATS measurement. The results also show that for the personal computers, the field strength measured in the GTEM! without cable manipulation are essentially the same as those on the OATS with cable manipulation. This implies a much faster and more consistent measurement.

MEASUREMENT ERROR, PRECISION, AND REPEATABILITY

The overall absolute rss error in the test instrumentation was 2.5 dB, and the probable instrumentation error was 1.7 dB. The precision of the measurement was 0.1 dB. From the descriptive statistics of the dipole-to-dipole OATS measurements, the probable variation of repeatability was 0.7 dB.

Conclusions

The following conclusions are drawn after conducting the testing described and after review and analysis of the test results.

TEST PROCEDURE SPECIFIC CONCLUSIONS

- **Must Control EUT Configuration**—There are several issues connected with this statement. An early procedure tried for the three orthogonal rotations was to rotate each component in place. This was quickly discarded in favor maintaining right relative positions of the components in EUT like a personal computer system.
- **Must Manage Cable Placement**—The relative positions of the interconnecting and power cables should be managed to maintain the EUT configuration to provide the highest levels of emanations from the EUT array.
- **Must Manage EUT Performance by Operating Software**—The GTEM! may be scanned in frequency at rates much higher than are normally associated with commercial EMC testing. The exercising software must be written with this in mind. For example, the optimal software approach in a GTEM! test is to write a single **H** to the screen and the printer, not a string of 80.
- **Must Use Precision Methods for Conduct of Measurements**—The care that is normally taken by conscientious test personnel is adequate. For GTEM! to OATS testing it was found that it is necessary to characterize measurement accessories such as preamplifiers and coaxial cables to a precision of 0.1 dB to achieve meaningful results.

MORE GENERAL CONCLUSIONS

- Direct comparison of dipole and personal computer measurements indicates a successful comparison measurement program.
- Statistical analysis indicates the direct comparison of GTEM! data and OATS data from a variety of devices and conditions is statistically valid.
- The GTEM! is a viable alternative facility for conducting radiated emissions testing.
- The time savings in the testing can be more than 8:1 in favor of the GTEM!. This indicates that higher test efficiency will allow substantially more testing to be done in the same amount of time as long as this is possible in a practical sense.
- The characteristics of the GTEM! allow operation in a corporate location with a rather high electromagnetic ambient environment, rather than a remote site like an OATS. This allows increased efficiency in travel time and possibly external test costs can be avoided. This makes the GTEM! ideal for EMC engineering development work.
- The GTEM! will have future applicability as a qualification facility for new products. The amount of data collected to date has shown that the differences in GTEM! data and OATS data are not statistically different. Additional statistical data is probably needed to establish a larger database, but it seems that this will be possible in the not too distant future.

Acknowledgements

The GTEM! was developed by Asea Brown Boveri of Baden, Switzerland. The technical content of this paper was prepared for presentation at the 1991 IEEE EMC Symposium.

References

ANSI 63.4/D11.4, Methods of Measurement of Radio-Noise Emissions from Low-Voltage Electrical and Electronic Equipment in the Range of 9 kHz to 40 GHz.

D. Hansen, P. Wilson, D. Koenigstein and H. Schaer, "A Broadband Alternative EMC Test Chamber Based on a TEM Cell Anechoic-Chamber Hybrid Approach", Proceedings of the 1989 International Symposium on Electromagnetic Compatibility; Nagoya, Japan, September 8-10, 1989, p. 133-137.

J. Osburn and G. Watkins, "New Test Set-Up Challenges Indoor, Outdoor Options", EMC Technology, V.9, No.3, May/June 1990, p. 37-39.

J. Osburn, "New Test Cell Offers Both Susceptibility and Radiated Emissions Capabilities," RF Design, August 1980, p. 39-47.

Federal Communications Commission GEN Docket No. 89-44, FUTHER NOTICE OF PROPOSED RULE MAKING, January 2, 1991.

ANSI C63.5-1988, American National Standard for Electromagnetic Compatibility—Radiated Emission Measurement sin Electromagnetic interference (EMI) Control—Calibration of Antennas.

William S. Peters and George W. Summers, Statistical Analysis for Business Decisions, Prentice-Hall, Inc., Englewood Cliffs, NJ. 1968, pp 377-385.

Ibid, pp 329-342.

Ibid, pp 152-154.

Ibid, pp 150-154.

CHARACTERISTIC AND WAVE IMPEDANCES OF A GTEM!

The characteristic impedance of the GTEM! is set by the internal dimensions, namely the width of the septum and the location, relative to the cross sectional dimensions of the cell. The GTEM! is an asymmetric transmission line, but the derivation follows the same approach as that used for a coaxial transmission line. For brevity and simplicity, the derivation of the impedances of a coaxial line is shown, instead of that of a GTEM!. Numerous literature references describe TEM and GTEM! cell characteristic impedance calculation; contact ETS-Lindgren for details.

A traditional coaxial transmission line, with inner conduct of radius a and outer conduct with inner radius b , has per unit length values of capacitance and inductance given by the equations

$$C = \frac{2\pi\epsilon_0}{\ln\left(\frac{b}{a}\right)} F / m \qquad L = \frac{\epsilon_0}{2\pi} \ln\left(\frac{b}{a}\right) H / m$$

Where

$$Z_0 = \sqrt{\frac{L}{C}} = \sqrt{\frac{\mu_0(\ln(b/a))^2}{(2\pi)^2 \epsilon_0}} = \frac{\ln(b/a)}{2\pi} \sqrt{\frac{\mu_0}{\epsilon_0}}$$

and

$$Z_0 = \eta_0 \frac{\ln(b/a)}{2\pi} = \frac{120\pi}{2\pi} \ln(b/a) = 60 \ln(b/a)$$

The value of the ratio of b/a can be selected to give a characteristic impedance of 50 ohms, while the wave impedance is 377 ohms between the conductors. This is a condition for TEM operation. While the geometry and the calculations are more complete, the same conditions hold true for the GTEM!. The characteristic impedance of the GTEM! is set by the cross-sectional dimensions to 50 ohms, while maintaining TEM operation with a wave impedance value of 377 ohms.

TERMINATION CHARACTERISTICS

Having derived the transmission line characteristics of a coaxial transmission line, it is postulated that the characteristics of a GTEM! match those of the coaxial line. The characteristic impedance is 50 ohms, and the TEM mode exists. The next step is description of the termination performance. It was stated previously that the GTEM! is a doubly-terminated or hybrid-load device. The two terminations are: resistive to match the current flowing in the septum, and RF absorbers to terminate (absorb) electromagnetic fields propagating to the termination.

The performances of these two terminations separately and in combination are discussed in the following sections.

Load Boards

The GTEM! uses a set of large printed circuit boards, which support the large number of resistors that compose the resistive termination. At low frequencies, the match of the resistor boards is dominant and the return loss of the GTEM! is that of the load boards by themselves. As frequency increases, the parasitic elements of the resistor chains degrade performance, as does the termination of the RF absorbers that appears as a capacitive element, causing the return loss to increase.

RF Absorber

The second part of the GTEM! hybrid termination is the array of RF absorbers. At low frequencies, the RF absorber shows very poor return loss. As frequency increases, however, the RF absorber match improves with a consequent improvement in the return loss due to the absorber.

Combined Performance

From a transmission line perspective, the two terminations act in parallel. The load boards dominate the response at low frequencies, while the RF absorbers dominate the response at higher frequencies. The transition between the responses shows as an increase in the return loss at what is called the critical, characteristic, or termination crossover frequency of the GTEM!. This critical frequency is seen as an increase in the VSWR of the GTEM!. The critical frequency depends on the size of the GTEM! and the volume of absorber.

This page intentionally left blank.

Appendix D: Related Downloads

A MS-DOS®-based version of the correlation routine described in *Software Computations* on page 46 may be downloaded from the ETS-Lindgren website at www.ets-lindgren.com.