



# TMC Design Corporation



## 2010 Product Catalog

ANTENNAS



ELECTRONIC  
WARFARE

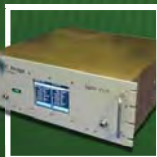

SPACE  
SYSTEMS



GSA Contract Holder

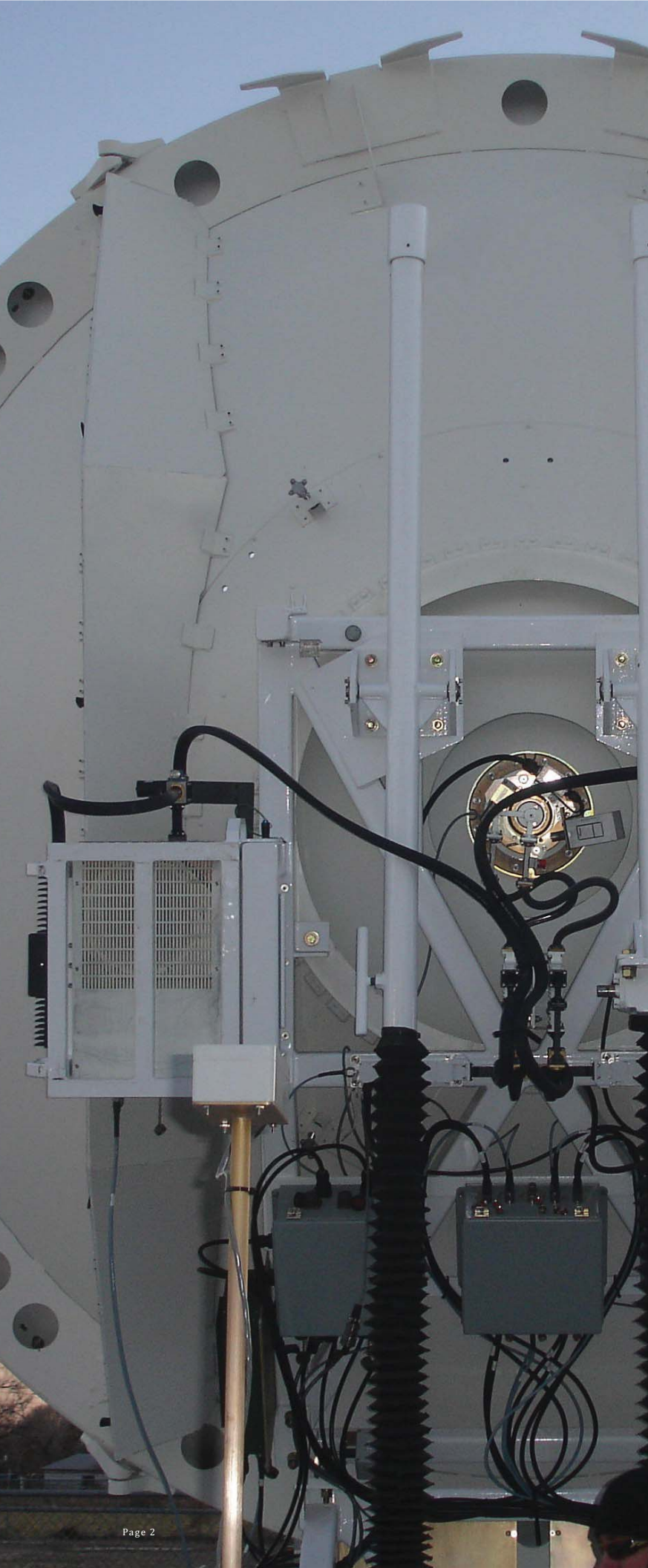

*TMC Design Corporation is an engineering services and manufacturing company providing state-of-the-art, cost-effective solutions to complex world issues for governmental and commercial customers. We are committed to providing our customers the latest in technology through the synergistic integration of antenna design, radio frequency electronics, state-of-the-art fabrication and intelligent software solutions to meet your specific requirements.*

*TMC Design is an AS9100:B/ISO9001:2000 certified supplier. This certification asserts TMC Design's dedication to meeting the quality expectations of the aerospace industry by establishing a quality management system that emphasizes customer satisfaction and continuous improvement.*

*If you do not find an engineering solution for your application in this 2010 catalog, call or e-mail us for a fast friendly quote to meet your specific needs. Our engineers are ready to meet your engineering needs with a low NRE cost and reasonable delivery time.*

## Featured



### Heavy Duty Trailers

TMC Design is a registered auto dealer that specializes in engineering and fabrication of heavy duty trailers. Our multi-purpose trailers will operate as mobile platforms for your terrestrial SATCOM system, deployable rapid assembly shelter, large antenna array and more. See pages 23 and 31 for more information.



### TMC Titan EW Antenna

The 3-foot TITAN antenna provides Omni-directional coverage from 20 to 6000 MHz. Ideal for electronic warfare applications. See page 11 for more information.



### TMC Advanced Threat Emulator

A newer model of the TATE is now available. The latest version boasts streamlined touch screen controls and a network adapter for remote controllability. See page 28

**www.tmcdesign.com**  
**575-382-4600**

<b>ANTENNA SELECTION GUIDE</b>	<b>4</b>
<b>ANTENNAS</b>	<b>5</b>
<b>Omni-Directional Antennas</b>	<b>5</b>
Bi-conical Antennas	6
Bi-conical Monopole Antennas	8
Disk-Spiral Antennas	10
Tri-conical Antennas	11
TMC Titan Tri-band Antennas	11
<b>Directional Antennas</b>	<b>12</b>
Dish Antennas	14
Flat-panel Antennas	15
Heli-cone Antennas	15
Helical Antennas	16
Horn Antennas	19
Low-Frequency Horn Trailers	23
<b>CUSTOM ANTENNAS</b>	<b>24</b>
<b>ELECTRONIC WARFARE SYSTEMS</b>	<b>25</b>
Wireless Bomb Jammers	26
Micro-GPS Jammers	27
TAVIA-32	27
TMC Advanced Threat Emulator Version 2	28
<b>SPACE SYSTEMS</b>	<b>29</b>
SATCOM Antenna Controller Systems	30
Tactical Multiband Antenna Trailer Systems	31
Space Situational Awareness Systems	32
<b>ANTENNA ACCESSORIES</b>	<b>33</b>
Antenna Box Feeds	33
RF Amplifiers	34
Towers and Masts	35

# ANTENNA SELECTION GUIDE



**CUSTOMIZING YOUR ANTENNA**

**COLOR OPTIONS** ■ ■ ■ ■  
A variety of paint options are available to fulfill your coating requirements. Federal Standard 595B colors, Chemical Agent Resistant Coating (CARC) or spot color schemes are available. Contact a TMC Design representative to specify coating options (*most popular colors shown above*).

**RF MATING OPTIONS**  
All TMC Design antennas can be modified to include an RF connector that best fits your application. Be sure to specify the connector that is needed or ask one of our representatives for assistance in finding an RF mating solution that will best fit your requirements.

**MOUNTING OPTIONS**  
Antennas can be modified to be mounted in the manner that best fits your requirements. Magnetic mounts are recommended for applications involving automobiles. A tripod will best fit situations where quick-setup and temporary emplacement necessary. Other options include antenna towers, and solar-powered mount systems for remote operation. Contact a TMC Design representative for assistance in choosing the best mounting option.

**UNIVERSAL FEATURES**

**RUGGEDIZED**  
Where it does not impede on antennas function all antennas are designed to operate under rigorous conditions and environments whenever possible.

**QUALITY CRAFTSMANSHIP**  
We are an AS9100 certified company. All antennas are designed and manufactured under with the auspices of our certified aerospace quality management program. All antennas are guaranteed for 1 year after delivery.

**HIGH-POWER OPTIONS**  
To increase range and improve reception, most TMC Design antennas can be modified operate in high-power applications.

## ANTENNA MODEL SELECTION

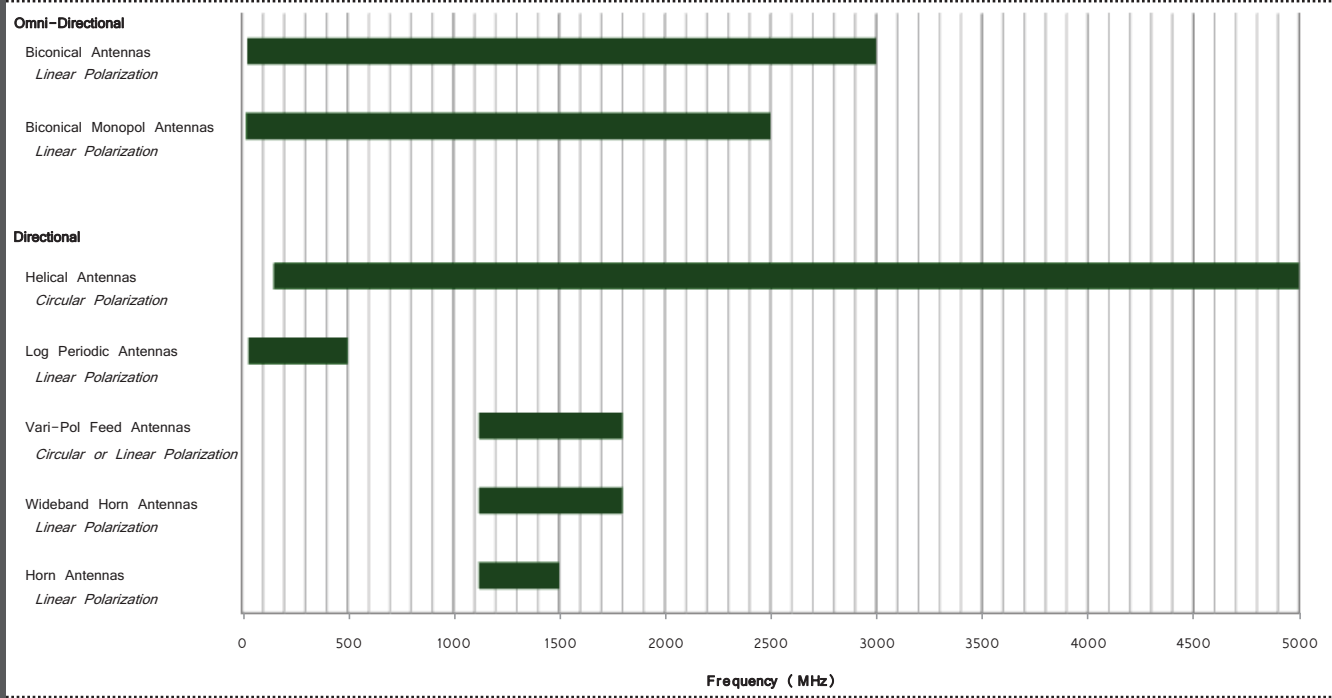

The above chart uses three factors to determine the antenna that will best suit your application. To use the chart, select the antenna that best meets the polarization, frequency and directivity requirements of your application. If we do not list the antenna you need please submit a request for a customized antenna design for a fast and friendly quotation. See page 24 for more information on custom antennas and projects.

**Polarization**



Polarization describes the method in which the electromagnetic wave is radiated from an antenna. Most antennas transmit in linear (vertical or horizontal) and circular polarization. Linear antenna transmissions achieve better distance and penetration whereas circular transmissions excel at maintaining communication links when the transmission path is obstructed.

**Frequency**



The application that the antenna will be used for often determines the frequency range that is required. For example, GPS applications occupy the 1.2 to 1.6 GHz band while the FM broadcast band ranges from 87.5 to 108.0 MHz. Select an antenna that fits the frequency range your application will be utilizing.

**Directivity**



Directivity indicates the direction of an antenna's radiating signal. An antenna that radiates in all directions equally (Omni directional) is considered to have no directionality. An antenna who's signal is more focused in fixed directions are considered directional. Antennas with no directivity should be used in applications where signals are expected from any bearing.

# OMNI-DIRECTIONAL ANTENNAS

Omni-directional antennas are generally used for communications systems or other systems that require equal coverage in all directions. Many of these antennas are made for mobile applications and can be provided with a magnetic base. For more information and pricing visit our web page at [www.tmcdesign.com](http://www.tmcdesign.com) or call our office headquarters in beautiful southern New Mexico at (575)-382-4600.

## Biconical Monopole (BM) Antennas



Biconical monopole designs are wide band and electrically small antennas that can offer coverage from 25 to 2000 MHz. Due to their wide-band and Omni-directional capability, they are ideal candidates for use with EW systems.

## Biconical (BC) Antennas



Biconical designs are ideal for use as mobile communication antennas due to their compact characteristics. All models can be delivered with various mounts to fit your mobile application.

## Triconical (TC) Antennas



Tri-Conical antenna models operate from 70 to 1600 MHz at 100 Watts CW and are designed for both transmit and receive applications. Commercial and military versions are available.

	Model Number	Frequency	Gain	HPBW
See p7	BC-0150-3/6	2-8 GHz	2.5 dB (Avg)	360x85
See p7	BC-0300	500-3000 MHz	3.5 dB (Avg)	360x85
See p8	BM-02	25-1000 MHz	-2 dB (Avg)	360x85
See p9	BM-03A	500-2000 MHz	3 dB (@F <sub>0</sub> )	360x85
See p9	BM-03-MM	0.5-2.0 GHz	4 dB (@F <sub>0</sub> )	360x85
See p10	BM-04	30-500 MHz	4 dB (@F <sub>0</sub> )	360x85
See p10	BM-04-HP	25-1000 MHz	4 dB (@F <sub>0</sub> )	360x85
See p6	BC-06r	1-2 GHz	10 dB (@F <sub>0</sub> )	120x45
See p6	BC-06r-hp	1-2 GHz	10 dB (@F <sub>0</sub> )	120x45
	BC-0300hp	1.2-1.6 GHz	4 dB (@F <sub>0</sub> )	360x85
See p8	BC-0375-B	550-900 MHz	3 dB (@F <sub>0</sub> )	360 x 85
	BC-7350	25-1200 MHz	4 dB (@F <sub>0</sub> )	360 x 85
See p10	DS-0300	1200 to 1600 MHz	2.39 dBIL	360x90
See p11	TC2700	70-1000 MHz	4 dB (@F <sub>0</sub> )	360x85
See p11	TMC Titan V2	20-6000 MHz	0 dB	360x65
See p11	TMC Titan V3	20-2000 MHz	0 dB	360x65

Rows of legacy BM-03 antennas ready for shipment. TMC Design has the facilities for mass production. Contact us for more information.

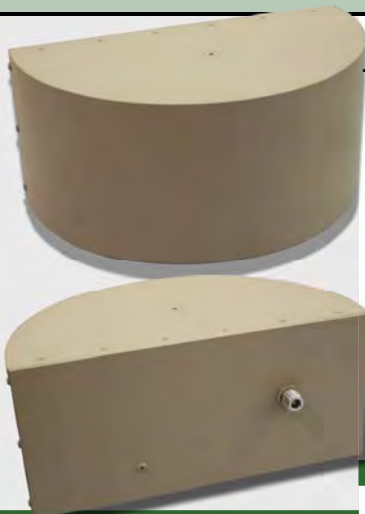

## BC-06r Wide-Band Communications Antenna

The BC-06r is a wide-band antenna ideal for applications requiring a wide azimuth beamwidth without complete omni-directional coverage. This small, mobile transmit and receive antenna is contained within a rugged, sealed fiberglass radome and can be provided with a magnetic mount for mobile applications (*available with optional tripod*). High-power operation models are also available (*BC-06r-HP, see specification table*).

### FEATURES

- Durable fiberglass construction
- 120 degree forward azimuth beamwidth
- High-power, 200 watt version available
- Magnetic mount included
- Ideal for point-to-point and mobile communications

### PERFORMANCE

#### BC-06r-D-L SPECIFICATIONS

FREQUENCY	1.1 to 1.7 GHz
GAIN	10 dB
POLARIZATION	Linear (Vertical)
HPBW	120 x 45°
MAX. POWER	100 W, CW
MAX. VSWR	1.8:1 max.
CONNECTOR	Type N
DIMENSIONS	6" x 6" x 12"
WEIGHT	5.5 lbs

#### BC-06r-HP SPECIFICATIONS

FREQUENCY	1.1 to 1.7 GHz
GAIN	10 dB
POLARIZATION	Linear (Vertical)
HPBW	120 x 45°
MAX. POWER	200 W, CW
MAX. VSWR	2.1:1 max.
CONNECTOR	Type N
DIMENSIONS	6" x 6" x 12"
WEIGHT	5.5 lbs

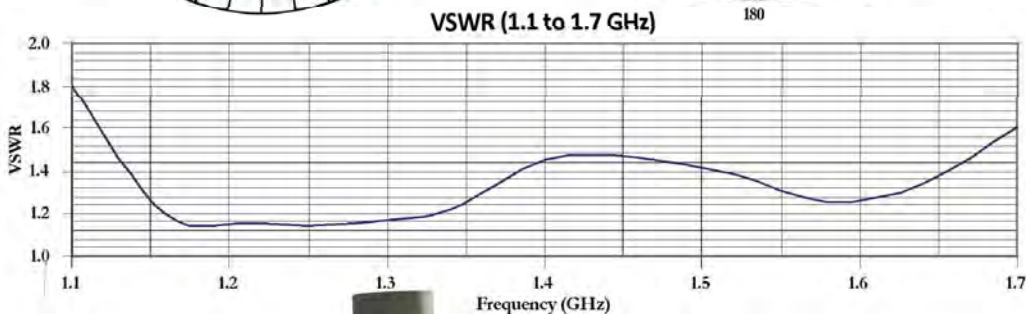
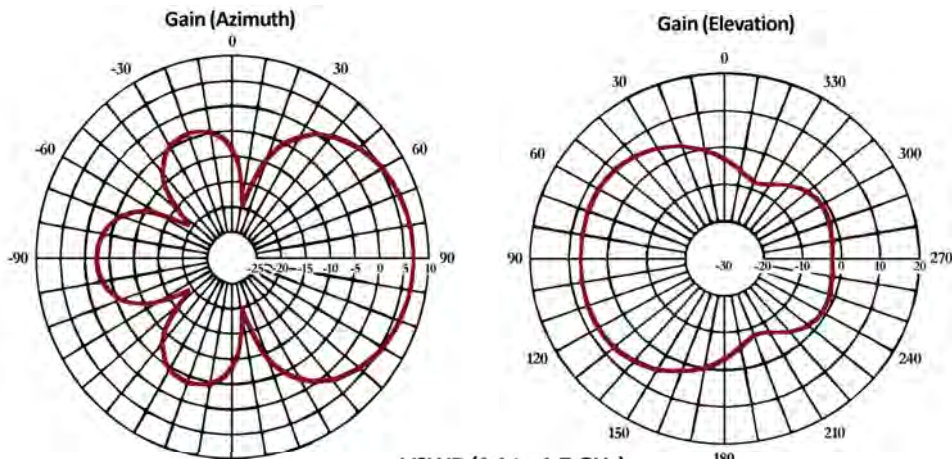

## BC-150-3/6 Very Wide Band Omni-Directional Antenna

### FEATURES

- Lightweight
- 360 degree coverage
- Quick and easy to setup
- Durable fiberglass construction
- Includes hardware for mounting to a pole

The BC-150-3/6 antenna is very wide band, electrically and physically small biconical monopole antenna designed for low frequency testing and wideband communications systems replacing large antennas and tuning systems. The antenna is housed and sealed in a rugged radome to insure long life and electrical repeatability.

### PERFORMANCE

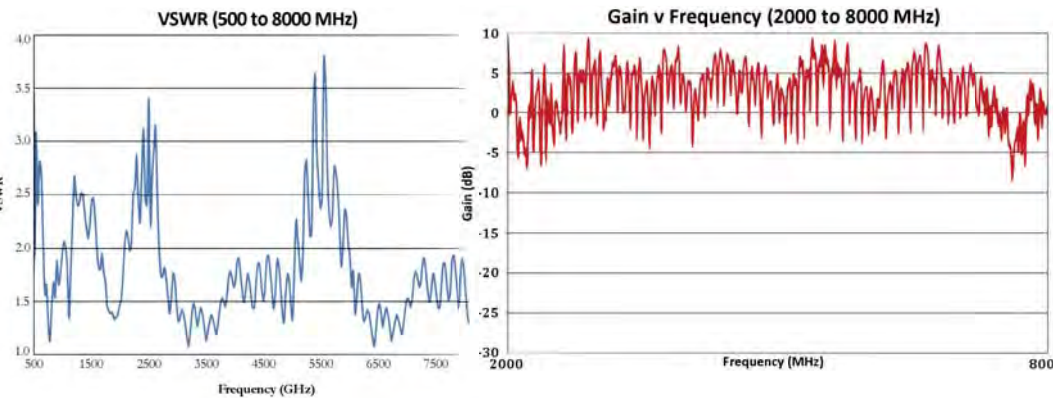

### SPECIFICATIONS

FREQUENCY	500 to 6000 MHz
GAIN	-3dB Avg. across band
POLARIZATION	Linear Vertical
HPBW	360 x 85°
MAX. POWER	100 W, CW
MAX. VSWR	3:1
CONNECTOR	Type N (female)
DIMENSIONS	8" h x 1.5" dia
WEIGHT	2 lbs

## BC-0300 Wide-Band Omni Directional Antenna

### FEATURES

- Lightweight
- 360 degree coverage
- Quick and easy to setup
- Durable fiberglass construction
- Magnetic base included

The BC-0300 antenna is a wide-band, electrically small biconical monopole antenna designed for low frequency testing and wideband communications systems, eliminating the need for large antennas or tuning systems. The antenna is housed and sealed in a rugged radome to ensure long life and electrical repeatability. A magnetic surface mount is included with the antenna. Optional connector, power and mounting configurations of this antenna are available. Contact a TMC Design representative to customize your BC-0300 antenna.

### PERFORMANCE

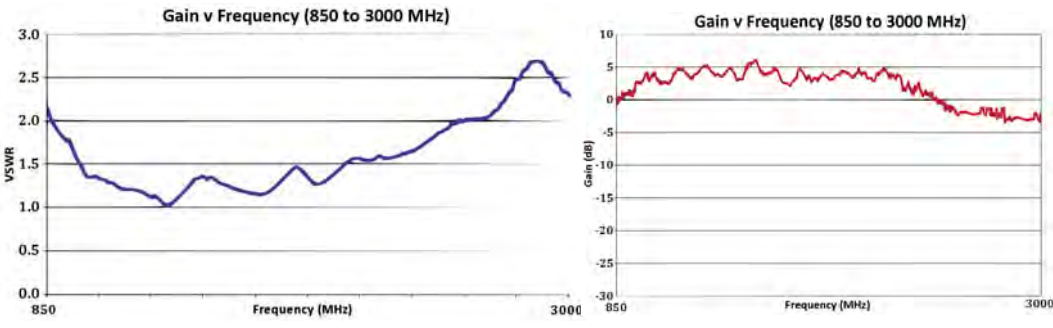

### SPECIFICATIONS

FREQUENCY	500 to 3000 MHz
GAIN	3.5 dB avg. across band
POLARIZATION	Linear (Vertical)
HPBW	360 x 85°
MAX. POWER	100 W, CW
MAX. VSWR	3:1
CONNECTOR	Type N (female)
DIMENSIONS	7.50" h x 3.25" dia
WEIGHT	4 lbs



## BC-0375-B Omni Directional Antenna

The BC-0375-B is a wide band (550 to 900 MHz), small, biconical transmit and receive antenna contained within a rugged, sealed radome. The result is a commercially priced antenna with the toughness and performance of a military antenna. The radome is encased in a durable fiberglass construction and sealed for extended outdoor use. The antenna is both electrically superior and easily deployable. Pole mounting hardware is supplied with the antenna. Different connectors, mounts and power handling modifications are available for purchase.

### FEATURES

- Lightweight
- 360 degree coverage
- Quick and easy to setup
- Durable fiberglass construction
- Pole-mount hardware included

### SPECIFICATIONS

FREQUENCY	550 to 900 MHz
GAIN	3.0 dB center freq.
POLARIZATION	Linear (Vertical)
HPBW	360 x 85° (@ f <sub>0</sub> )
MAX. POWER	50 W, CW
MAX. VSWR	2.0:1
CONNECTOR	TNC, Type-N
DIMENSIONS	8.200" h x 2.875" dia
WEIGHT	1.2 lbs

### PERFORMANCE

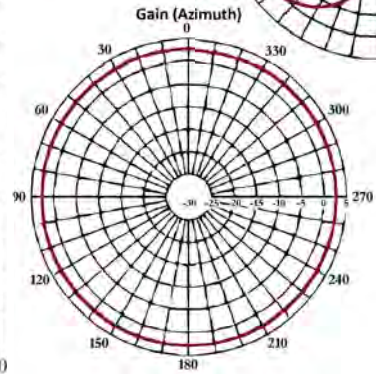
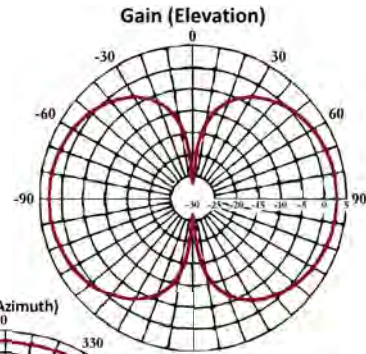
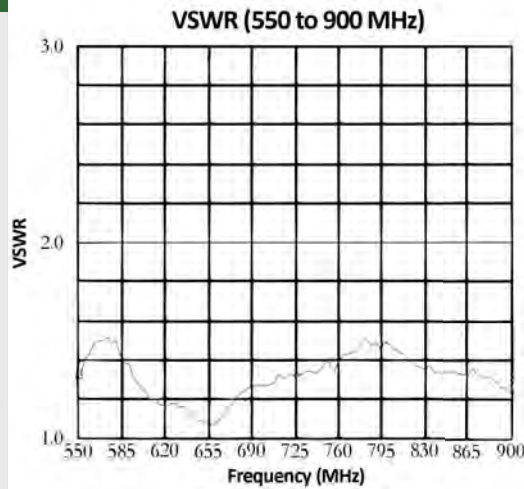

## BM-02 Very-Wide Band Omni Directional Antenna

The BM-02 antenna is very wide band (25 to 1000 MHz), electrically small biconical monopole antenna designed for low frequency testing and wideband communications systems eliminating the need for large antennas or tuning systems.

The antenna is housed and sealed in a rugged radome to insure long life and electrical repeatability. A magnetic mount is provided with the antenna for use on metal surfaces. Contact a TMC Design sales representative for available mounting, mating and power options.

### FEATURES

- Lightweight
- 360 degree coverage
- Durable construction
- Quick and easy to setup
- Durable fiberglass construction
- Includes magnetic base for mounting to metal surfaces

### SPECIFICATIONS

FREQUENCY	25 to 1000 MHz
GAIN	-3dB avg. across band
POLARIZATION	RHCP
HPBW	360 x 85°
MAX. POWER	100 W, CW
MAX. VSWR	3:1
CONNECTOR	Type N (female)
HEIGHT	16"
DIAMETER	3.126"
WEIGHT	4 lbs

### PERFORMANCE

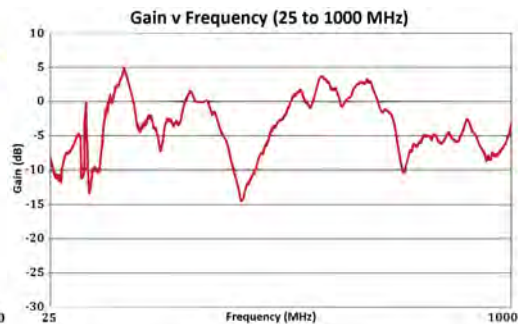
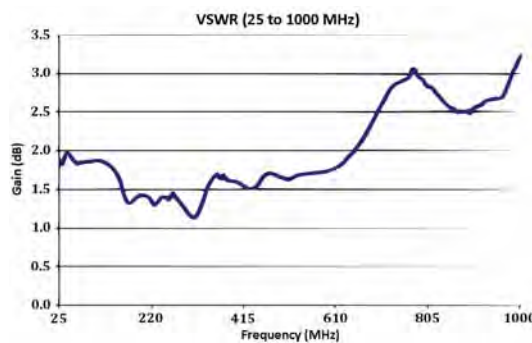



# BM-03 Series Wideband Antennas

## FEATURES

- Lightweight
- 360 degree coverage
- Durable fiberglass construction
- Quick and easy setup
- Multiple vehicle-mount options
- Impact tested
- Useful in EW applications

The BM-03 series antennas are wide band, biconical transmit and receive antennas. These hand-built antennas are sealed within a fiberglass radome, making them ideal for outdoor use.

Current models include the BM-03A and BM-03-MM. The BM-03-MM variant is modified for use with an HMMWV. The BM-03A variant has multiple mounting options and can be provided with pole-mount, mirror-mount or magnet-mount bases. Both models pass MIL-STD-810 shock, temperature and vibration testing requirements for protection of encased electronic equipment.

The 360 degree coverage provided by these antennas makes them ideal for use on vehicles and in electronic warfare applications.

*The BM-03A has multiple mounting options. The mirror-mount is most popular mount configuration.*

*The BM-03-MM variant comes with a Single Channel Ground and Airborne Radio System (SINCGARS) vehicle mount for use on HMMWVs.*

## BM-03A SPECIFICATIONS

FREQUENCY	500 to 2000 MHz
GAIN	4 dB (F <sub>0</sub> )
POLARIZATION	Linear (Vertical)
HPBW	360 x 85° (F <sub>0</sub> )
MAX. POWER	100 W, CW
MAX. VSWR	3:1 (max)
CONNECTOR	Type N (female)
DIMENSIONS	13.5" h x 3.25" dia
WEIGHT	12 lbs

## BM-03-MM SPECIFICATIONS

FREQUENCY	500 to 2000 MHz
GAIN	4 dB (F <sub>0</sub> )
POLARIZATION	Linear (Vertical)
HPBW	360 x 85° (F <sub>0</sub> )
MAX. POWER	100 W, CW
MAX. VSWR	3:1 (max)
CONNECTOR	Type N (female)
DIMENSIONS	64.5" h x 5.5" dia
WEIGHT	12 lbs

## PERFORMANCE

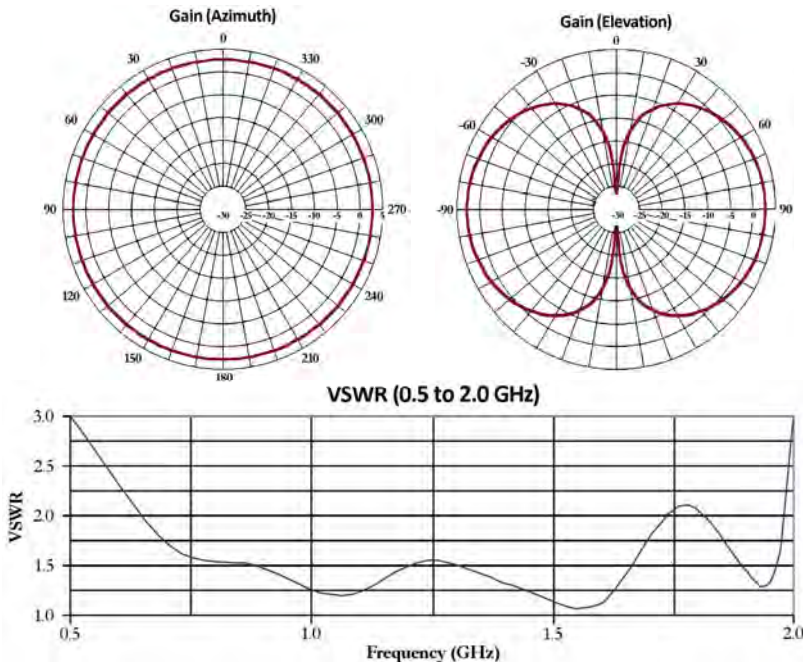



## BM-04 Wide Band Communications Antenna

The BM-04 is a very wide band, electrically small biconical antenna designed to allow coverage of the VHF/FM communications band (30-88 MHz) without the need for tuning systems. The very-wide bandwidth will also transmit fast rise pulses with high fidelity for HPM operations. This rugged antenna is portable, easily shipped/stored and can be set up within minutes. A high-power model is also available with a frequency range of 25 to 1000 MHz and increased power handling to 1000 watts. Guy kit are included with orders for outdoor operation in windy environments.

### PERFORMANCE

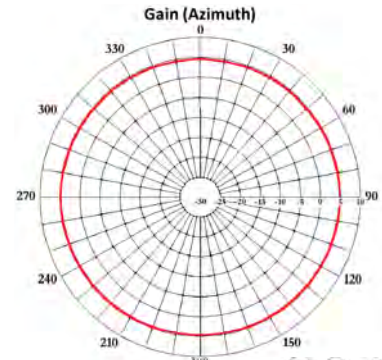

Gain (Azimuth)

Gain (Elevation)

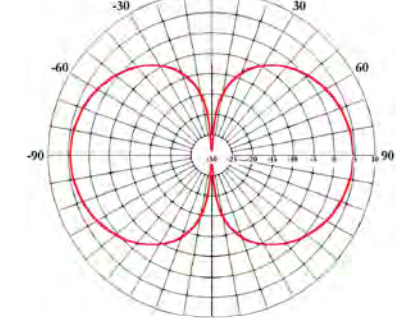

VSWR (0 to 500 MHz)

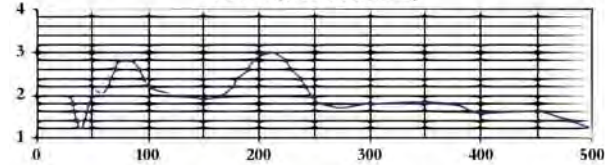

SPECIFICATIONS	
FREQUENCY	30 to 500 MHz
GAIN	4 dB
POLARIZATION	Linear
HPBW	360 x 85 (@ f <sub>0</sub> )
MAX. POWER	100 watts
MAX. VSWR	
CONNECTOR	Type-N
DIMENSIONS	72.5" x 38.2"
WEIGHT	28.6 lbs.

FEATURES	
●	Low frequency communications antenna
●	Slim, lightweight design
●	Omni-directional coverage
●	Quick and easy to setup
●	Made for outdoor use
●	Guy kit included for windy environments
●	1000 MHz, 1000 W model available



## DS-0300 Disk Spiral Antenna

The DS-0300 is a wide band, small biconical spiral transmit/receive antenna contained within a rugged, sealed epoxy-glass radome. The result is an exact threat representative antenna in a robust package with standard N-Type connectors. The operating range of the antenna makes it an ideal candidate for GPS applications. The antenna is available in a high-powered version and a wide variety of mounting options including a vehicular magnetic mounts or deployable tower mounts.

SPECIFICATIONS	
FREQUENCY	1.2 to 1.6 GHz
GAIN	2.39 dBiL
POLARIZATION	Linear (typ. Vertical)
HPBW	360 x 90° (@ f <sub>0</sub> )
MAX. POWER	50 W, CW
MAX. VSWR	1.5:1 typ.; 2.0:1 max.
CONNECTOR	Type N (female)
DIMENSIONS	4.0" x 3.0" x 3.0"
WEIGHT	2.2 lbs

PERFORMANCE	
Gain (Azimuth)	
Gain (Elevation)	

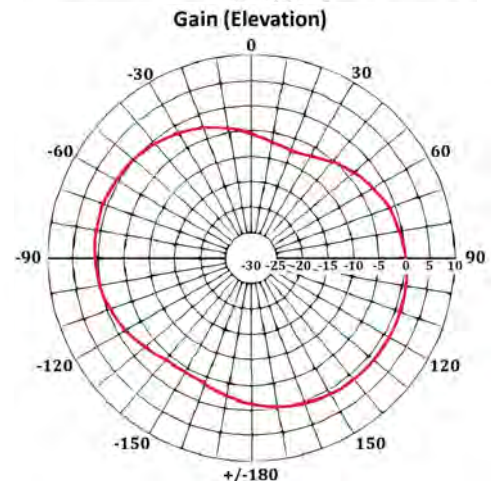
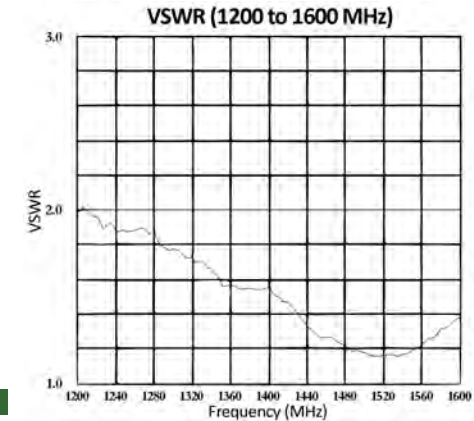
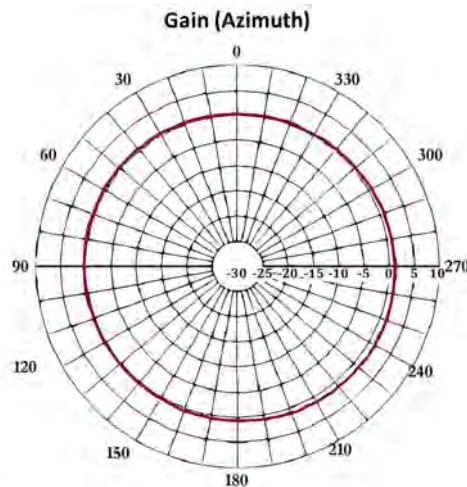

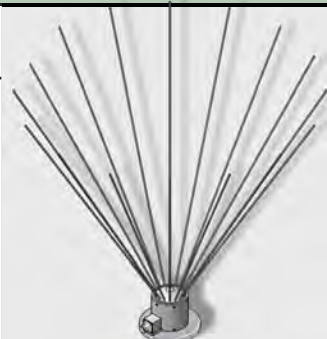

# TC-2700 Wideband Mobile Communications Antenna

## PERFORMANCE

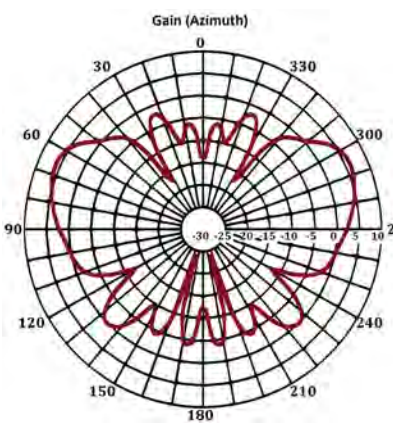
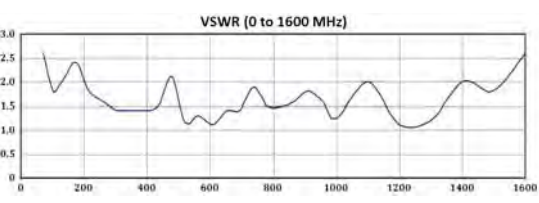

The TC2700 is a very wide band, mobile communications antenna designed for both transmit (100 watts CW) and receive applications. The antenna comes with a powerful magnetic base that firmly attaches to any steel surface (sufficient ground plane required). The unit is housed in a sealed radome with replaceable elements.

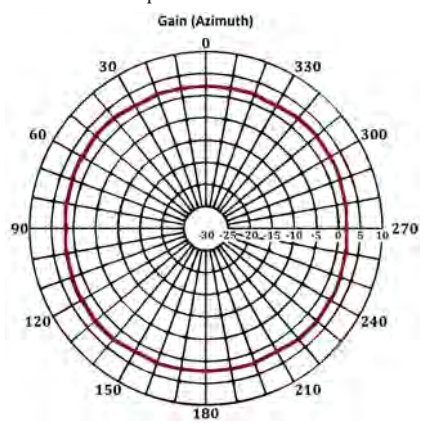

## SPECIFICATIONS

FREQUENCY	70 to 1600 MHz
GAIN	4dB
POLARIZATION	Linear Vertical
HPBW	360 x 40° (@f <sub>0</sub> )
MAX. POWER	100 W, CW
MAX. VSWR	2.5:1 max.
CONNECTOR	Type N (female)
DIMENSIONS	25" x 27"
WEIGHT	3.9 lbs

# TMC TITAN Wideband Electronic Warfare Antennas

TMC Design's newest electronic warfare antennas, the **Titan V2** and **Titan V3**, offer coverage from 25 to 6000 MHz

The TMC Titan V.2 antenna is a tri-band high-power omni-directional antenna with a wide bandwidth of 20 to 6000 MHz, divided among **three** overlapping bands.

The TMC Titan V.3 antenna is a dual-band high power omni-directional antenna with a wide bandwidth of 20

to 2000 MHz, divided into **two** overlapping bands.

Both antennas are manufactured with sturdy radomes for ruggedized, outdoor use and are conveniently attached to a SINGGARS Antenna Vehicle Mount for easy deployment.

## PERFORMANCE

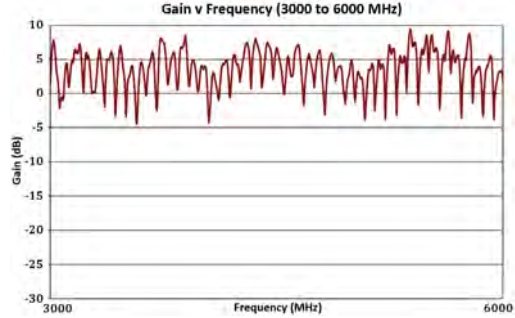
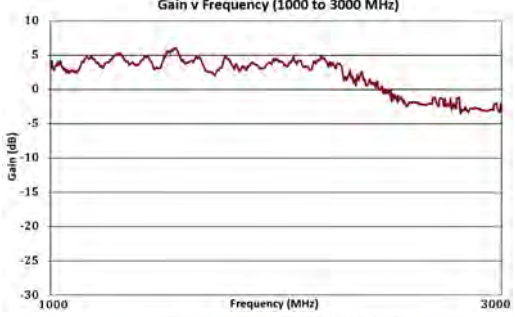
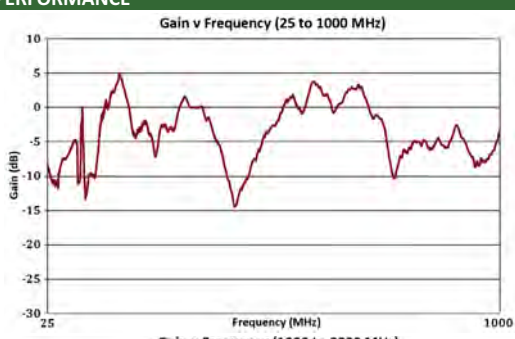
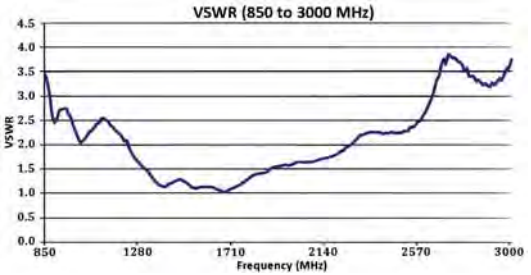
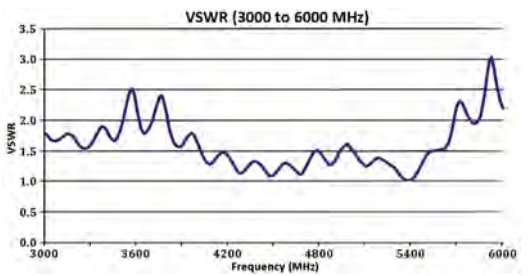
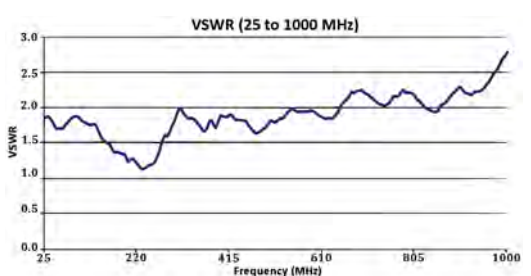

## SPECIFICATIONS

FREQUENCY	20 to 6000 MHz
GAIN	0dB avg.
POLARIZATION	Linear, Vertical
HPBW	360 x 65°
MAX. POWER	100 W, CW
MAX. VSWR	3.5:1
CONNECTOR	Type N (female)
DIMENSIONS	36.75" x 4" dia.
WEIGHT	5.25 lbs

# DIRECTIONAL ANTENNAS

Directional Antennas are generally used for systems that require narrow beamwidth and highly directed energy. These narrow beam antennas can provide a large amount of energy over a small coverage area.

When used for point-to-point communications systems (such as satellite links), these very-directive antennas will greatly reduce power requirements. In EW applications, highly directive antennas increase the field strength at the target at a fraction of the cost of higher output amplifiers. The most effective results are obtained when combined with higher power amplifiers.

Our quality trailer-mounted, highly-directional dish antennas are available at a reasonable cost. Visit our web page, [www.tmcdesign.com](http://www.tmcdesign.com), or call TMC Design's Las Cruces, New Mexico offices at (575) 382-4600 for a fast, friendly quote.

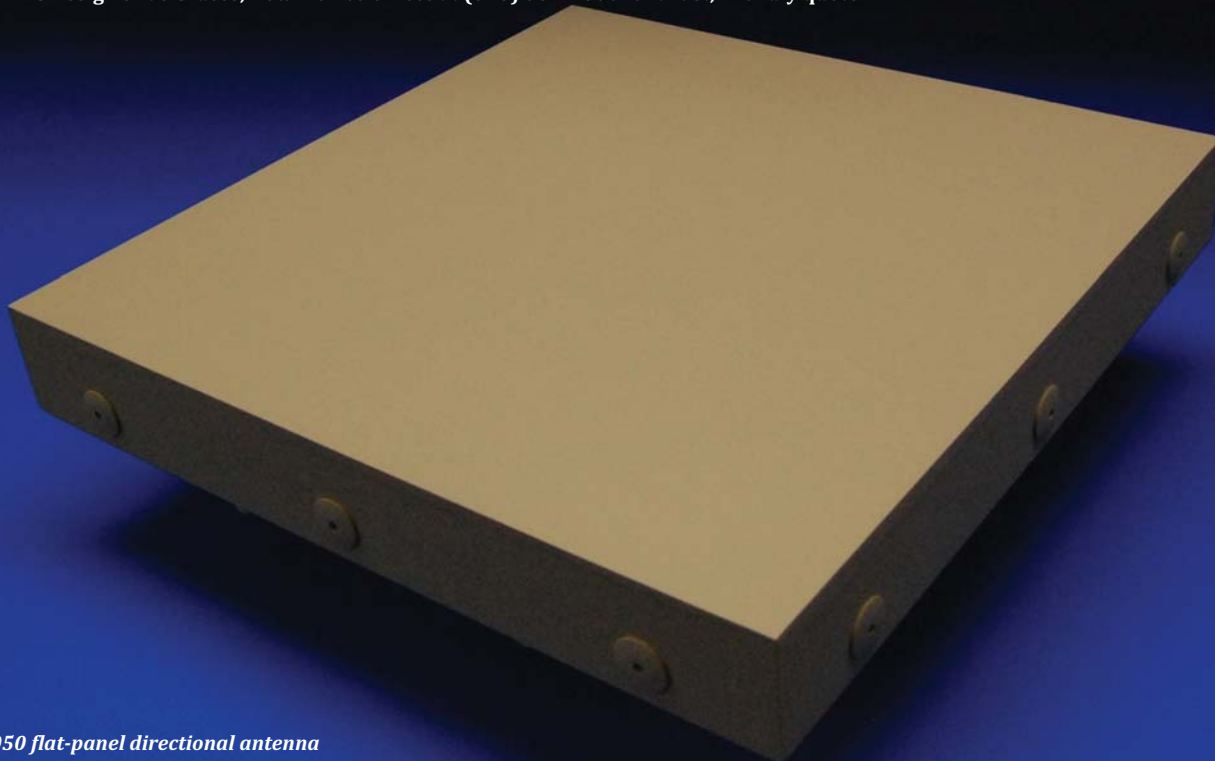

*FS-1050 flat-panel directional antenna*

## DIRECTIONAL ANTENNA MODELS

### Parabolic Dish (BF) Antennas



Dish antennas are highly directive and typically exhibit high gain and low cross-polarization values. The parabolic dish antenna is widely known for its uses in satellite communications. However, the antenna is also useful in wireless applications at frequencies of 1 GHz and above. It is common to see this antenna in radio, television, communication, data and RADAR systems that operate in UHF and SHF allocations.

Model	Frequency (GHz)	Gain (dB)	Beamwidth (deg)
<b>BF-350-24</b>	2.0 to 3.0	20.0	15.40
<b>BF-550-24</b>	1.4 to 2.0	16.6	20.00
<b>BF-550-72</b>	1.0 to 2.0	24.0	8.28

See p14

See p14

See p14

Our dish antennas and feeds are designed and fabricated to meet customer specifications. In addition to dish fabrication, design and alignment capabilities; we also provide test and validation services or can suggest alternate test facilities for customers that prefer independent test and validation service. TMC Design antennas are currently used by several US Govt. entities for ground & air based communication, test and EW systems.

### Flat Panel Antennas



Flat panel antennas offer directive and gain performance comparable to Yagi-Uda, Log Periodic and dish models. However, the flat-panel's straightforward and simple design render them an economic alternative to other models.

Model	Frequency (GHz)	Gain (dB)	Beamwidth (deg)
<b>FS-1050-RHCP</b>	1.2 to 1.6	7	66x65
<b>FS-1050-LHCP</b>	1.2 to 1.6	7	66x65
<b>FS-1050-HP</b>	1.2 to 1.6	7	66x65

See p15

See p15

See p15

Moreover, the intrinsic casing of this model has earned it a reputation as a reliable choice for applications where outdoor operation and ruggedness are a requirement

TMC Design currently manufactures specialized flat panel models that operate in designated GPS frequencies. Available models are circular polarized (right-hand and left-hand). If current models do not perfectly suit your requirements contact a TMC Design representative to request a customized flat-panel design.

### Helical (HE) Antennas



Helical antennas have an inherent helix in their design. As a result, these antennas radiate RF in travelling waves through a corkscrew pattern. Signals travelling on these circular waves can be carried on any of its axial planes of symmetry. This method of transmission results in a signal that is better at penetrating and bending around objects, making it more resistant to signal degradation from common communication obstacles such as multi-path, phasing, weather and line-of sight.

Helical antennas are available that can provide continuous coverage from 100 MHz to 6000 MHz (6 GHz) in both left or right hand circular polarization. All helical models can be manufactured in both commercial or military grades. Contact us for more information on delivery and custom applications.

Model	Frequency MHz	Gain dB	Beamwidth Degrees
HE-0580-10	5000-6000	~11.75	35
HE-0075-10	4000-5000	-	-
HE-0150-8	1530-2730	-	-
HE-0200-10	1500-2250	12.4	35
HE-0200-18	1500-2250	15	26
HE-0238-8	1200-1800	10.5	40
HE-0238-11	1200-1800	11.5	35
HE-0238-13	1200-1800	13	30
HE-0238-165-HH	1200-1600	15	27
HE-0300-8	1000-1500	11.4	38
HE-0500-10	480-880	10	45
HE-1000-6	225-400	10	45
HE-1000-6EC	225-400	10	45
HE-1000-10	230-360	10	45
HE-1500-4	200-300	8.4	54
HE-2000-4	150-225	8.4	54

See p 18

See p 16

See p 16

See p 16

See p 17

See p 18

See p 18

### Log Periodic (LP) Antennas



Log periodic antennas are handy in directional applications where wide bandwidth and moderate gain is a requirement. Models with higher gain values often increase dramatically in physical size. The log-periodic antenna is reserved for applications allocated to the HF, VHF and UHF portions of the RF frequency spectrum.

TMC Design Corporation has many years experience in the design and fabrication of high power log periodic antennas. We offer log periodic antennas covering the frequency spectrum from 20 MHz to 2 GHz available in commercial or military grades. Contact us for pricing and delivery.

Model	Frequency MHz	Gain dB	Beamwidth Degrees
LP-02400	350 to 425	8.7	62x90
LP-03000	160 to 200	7.5	60x90
LP-03500	135 to 160	7.5	60x90
LP-18000	400 to 500	10.3	95x75

### Horn (HO) Antennas



Horn antennas characteristically provide significant directivity and gain. While horns are capable antennas they are also used as gain standards and feeds for parabolic dish antennas. Horns are commonly used in applications operating at microwave frequencies, specifically the UHF (300 MHz to 3 GHz) range.

Existing horn models start at 150 MHz and reach 15 GHz. All models are available in linear or circular polarization. To avoid specialization, automated variable polarization systems are available. Contact a TMC Design representative for horn pricing and delivery information.

Model	Frequency (GHz)	Gain (dB)	Beamwidth (deg)
HO-75-24	10.0 to 15.0	24	10x10
HO-90-RH	8.20 to 12.40	8	30x120
HO-90-S	8.20 to 12.40	10	30x90
HO-90-18	8.20 to 12.40	18	20x20
HO-90-20	8.20 to 12.40	20	15x15
HO-90-24	8.20 to 12.40	24	10x10
HO-112-RH	7.05 to 10.00	8	30x120
HO-112-S	7.05 to 10.00	10	30x90
HO-112-18	7.05 to 10.00	18	20x20
HO-112-20	7.05 to 10.00	20	15x15
HO-112-24	7.05 to 10.00	24	10x10
HO-112-RH	7.05 to 10.00	8	30x120
HO-137-RH	5.85 to 8.20	8	30x120
HO-137-S	5.85 to 8.20	10	30x90
HO-137-18	5.85 to 8.20	18	20x20
HO-137-20	5.85 to 8.20	20	15x15
HO-137-24	5.85 to 8.20	24	10x10
HO-187-S	3.95 to 5.85	10	30x90
HO-187-18	3.95 to 5.85	18	20x20
HO-187-20	3.95 to 5.85	20	15x15
HO-187-24	3.95 to 5.85	24	10x10
HO-284-S	2.60 to 3.95	10	30x90
HO-284-18	2.60 to 3.95	18	20x20
HO-284-20	2.60 to 3.95	20	15x15
HO-284-24	2.60 to 3.95	24	10x10
HO-430-S	1.70 to 2.60	10	30x90
HO-430-10-HH	1.70 to 2.60	10	44x72
HO-430-18	1.70 to 2.60	18	20x20
HO-430-20	1.70 to 2.60	20	15x15
HO-430-24	1.70 to 2.60	24	10.5x9
HO-650-S	1.12 to 1.70	10	30x90
HO-650-18	1.12 to 1.70	18	20x20
HO-650-20	1.12 to 1.70	20	15x15
HO-650-24	1.12 to 1.70	24	11x9.8
HO-1200-15	.615 to .940	15	30x30
HO-2450-15	.301 to .460	15	30x30
HO-4925-13	.150 to .229	13	44x44

See p19

See p19

See p20

See p20

See p21

See p21

See p22

See p22

See p23

See p23

See p23



### BF-350-24 Dish Antenna

The BF-350-24 antenna is a polarization diverse dish feed with a 24" diameter prime-focus parabolic antenna designed to be electrically superior. A vari-pol box feed allows the antenna to be used in any desired polarization.

**PERFORMANCE**

SPECIFICATIONS	
FREQUENCY	2.0 to 3.0 GHz
GAIN	18 dB
POLARIZATION	Circular or Linear
HPBW	15.4°
MAX. POWER	20 Watts CW
MAX. VSWR	2:1
CONNECTOR	SMA
DIMENSIONS	24" dia. x 16.5" h
WEIGHT	5.25 lbs

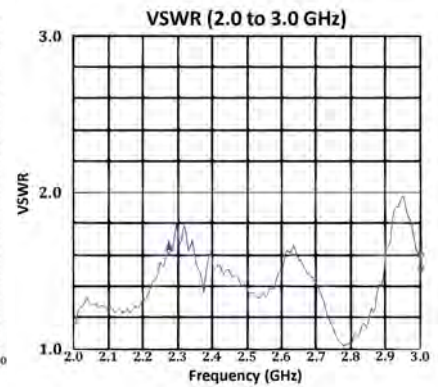
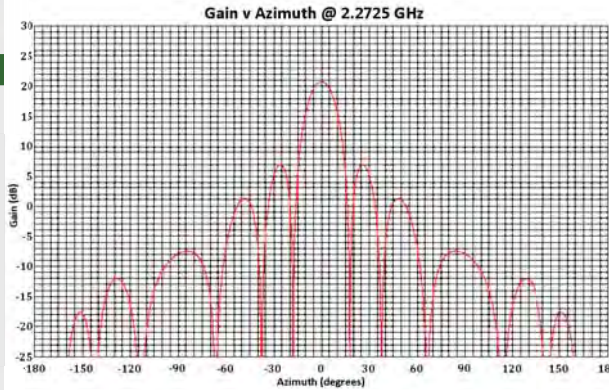

### BF-550-24 Dish Antenna

The BF-550-24 antenna is an electrically superior, polarization-diverse dish feed with a 24" diameter prime focus parabolic antenna that has been designed for operation in the 1400 to 2000 MHz range in any desired polarization.

**PERFORMANCE**

SPECIFICATIONS	
FREQUENCY	1.4 to 2.0 GHz
GAIN	16.6 dBic (F <sub>0</sub> )
POLARIZATION	Circular or Linear
HPBW	20° (1.575 GHz)
MAX. POWER	20 Watts CW
MAX. VSWR	2:1
CONNECTOR	Type-N (female)
DIMENSIONS	24" dia. x 16.5" h
WEIGHT	5.25 lbs.

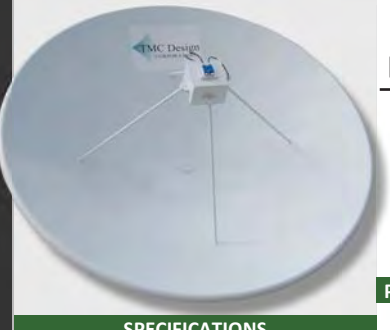
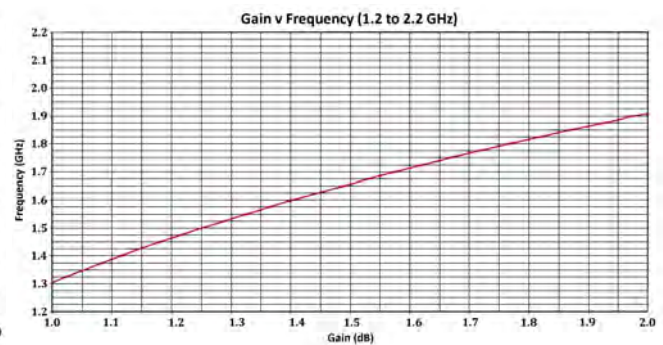
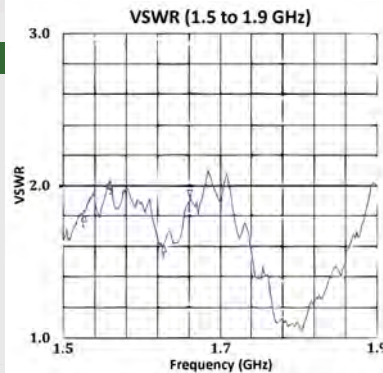

### BF-550-72 Dish Antenna

TMC Design's newest dish antenna, the BF-550-72, is an ideal directive L-band solution. This antenna's design includes a vari-pol feed allowing it to operate in both Linear or Circular polarization.

The dish feed has an approximate 72" diameter and comes in a variety of mounting options.

**PERFORMANCE**

SPECIFICATIONS	
FREQUENCY	1.0 to 2.0 GHz
GAIN	24 dBi @ 1.5 GHz
POLARIZATION	Circular or Linear
HPBW	8.28°
MAX. POWER	50 Watts
MAX. VSWR	2:1
CONNECTOR	SMA
DIMENSIONS	27" l x 68" h
WEIGHT	20 lbs

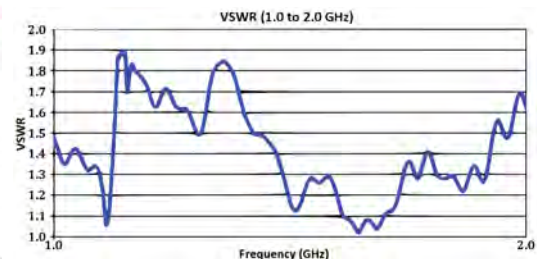
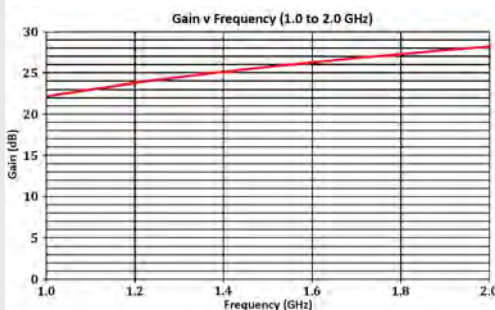

# FS-1050-RHCP GPS Antenna

## FEATURES

- Weatherproof enclosure
- -20° to +150° F operating temperature
- Optional connectors (SMA, TMC, etc.)
- High power model available

The FS-1050 is a wide band, flat spiral transmit and receive antenna contained within a rugged, sealed epoxy-glass radome. The result is an exact threat representative antenna in a robust package. The antenna is available in a high power versions and with a deployable tower mount. The unit is also available with an internal modulator and amplifier for operation as a stand-alone jammer system.

## PERFORMANCE

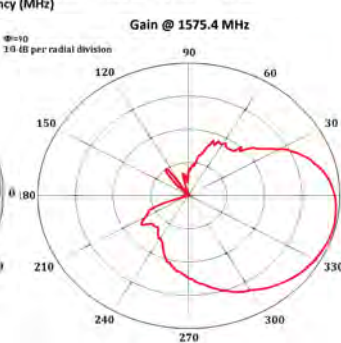
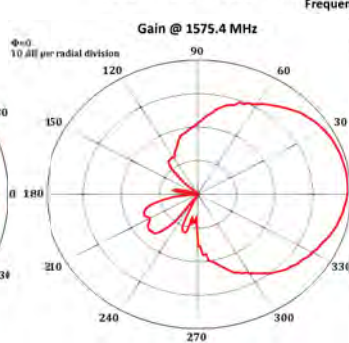
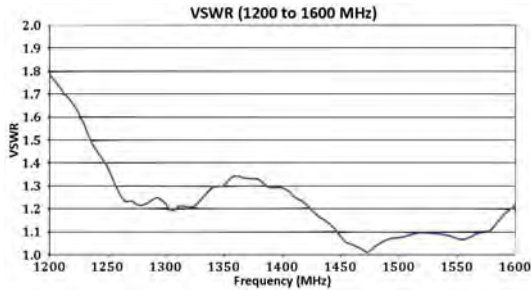
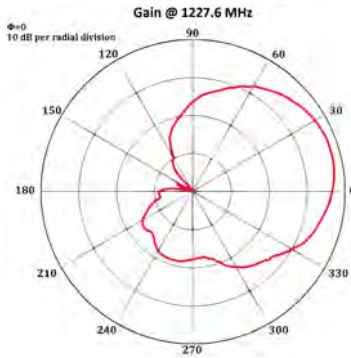

# HC-238-13 Helicone Antenna

## PERFORMANCE

The TMC HC-238-13 antenna helical/horn hybrid for use in high-power L-Band applications. The helical/horn combination provides low sidelobe levels while maintaining a solid gain. The antenna operates from 1.2 to 1.6 GHz making it ideal for use in GPS-related applications.

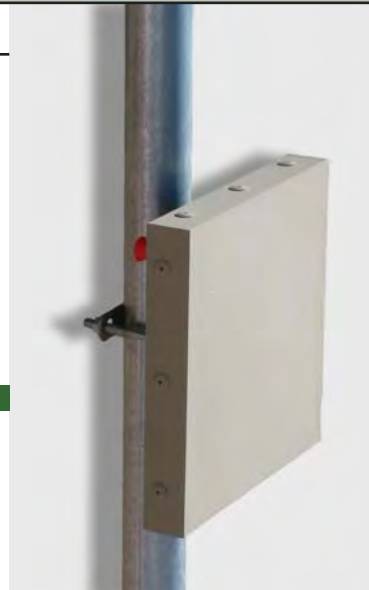
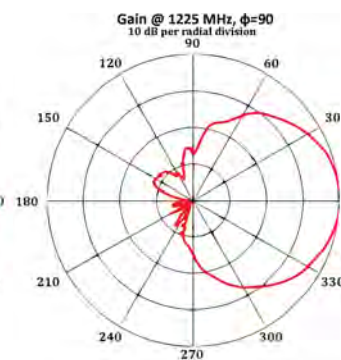
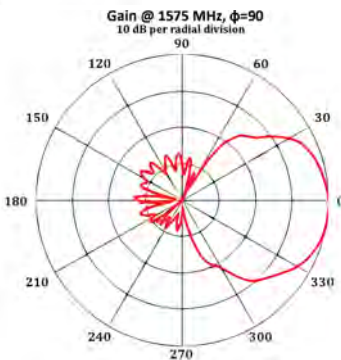
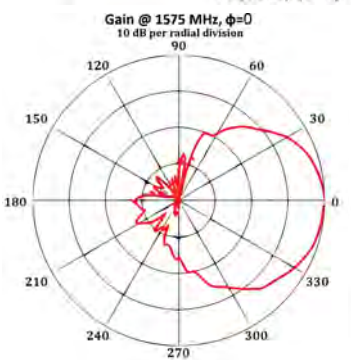
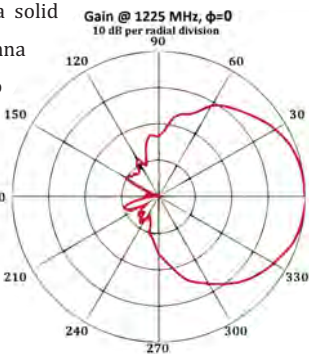
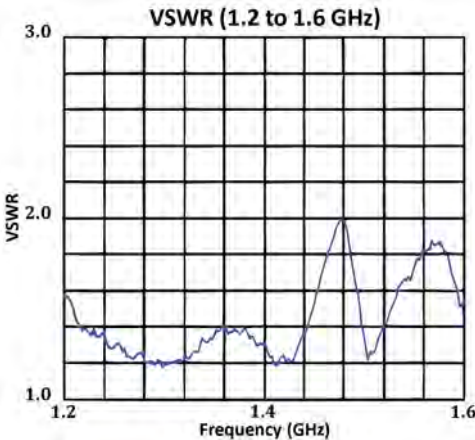

## SPECIFICATIONS

FREQUENCY	1.2 to 1.6 GHz
GAIN	7 dBiC
POLARIZATION	RHCP
HPBW	65° x 65° @f <sub>0</sub>
MAX. POWER	25 Watts, CW
MAX. VSWR	1.5:1typ; 2:1max
CONNECTOR	Type-N
DIMENSIONS	11" x 11" x 3"
WEIGHT	5.25 lbs



## SPECIFICATIONS

FREQUENCY	1.2 to 1.6 GHz
GAIN	7 dBiC
POLARIZATION	RHCP
HPBW	65° x 65° @f <sub>0</sub>
MAX. POWER	25 Watts, CW
MAX. VSWR	1.5:1typ; 2:1max
CONNECTOR	Type-N
DIMENSIONS	11" x 11" x 3"
WEIGHT	5.25 lbs

ANTENNAS  
Directional Antennas

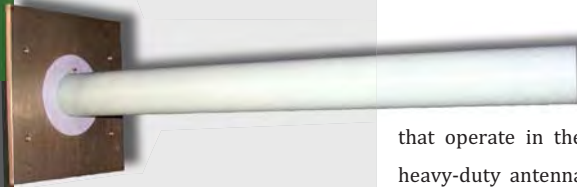

## HE-238 Series Helical Antennas

The HE-238 series antennas are a family of high power, wide band, helical antennas that operate in the 1.2 to 1.8 GHz range. These heavy-duty antennas will provide years of reliable service in either military or commercial applications.

Antennas orders come with pole-mounting hardware. A motorized dual-mount, which will house up to two HE-238 antennas, is also available. The dual-mount is available in manual and motorized modes. The motorized mount will allow users to reposition the antenna (along azimuth and elevation planes) remotely for remote applications.

These antennas will provide years of trouble-free service in extreme environments and are currently in use by several U.S. Military installations in remote locations.

### FEATURES

- Ideal for GPS applications
- Ideal for GSM mobile phone applications
- RHCP and LHCP models available
- Sealed in rugged radome for years of outdoor use
- Lightweight
- Durable
- Suitable for high-power applications
- Adjustable dual mount available

### HE-238-8 SPECIFICATIONS

FREQUENCY	1.2 to 1.8 GHz
GAIN	10.5 dB
POLARIZATION	RHCP
HPBW	40°
MAX. POWER	500 W
MAX. VSWR	2:1 max.
CONNECTOR	Type N (female)

### HE-238-11 SPECIFICATIONS

FREQUENCY	1.2 to 1.8 GHz
GAIN	11.5 dB
POLARIZATION	RHCP
HPBW	35°
MAX. POWER	500 W
MAX. VSWR	2:1 max.
CONNECTOR	Type N (female)

### HE-238-13 SPECIFICATIONS

FREQUENCY	1.2 to 1.8 GHz
GAIN	13 dB
POLARIZATION	RHCP
HPBW	30°
MAX. POWER	500 W
MAX. VSWR	2:1 max.
CONNECTOR	Type N (female)
DIMENSIONS	30" (l) x 12" (w)
WEIGHT	2 lbs

### MOTORIZED DUAL MOUNT

AZIMUTH	360°
ELEVATION	-15° to +15°

### PERFORMANCE

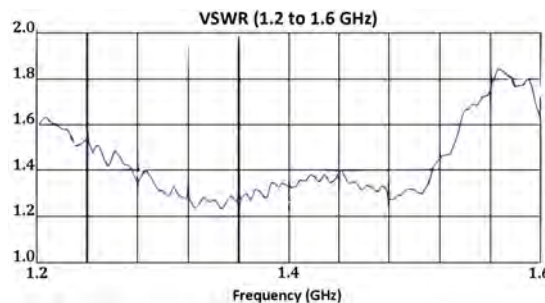
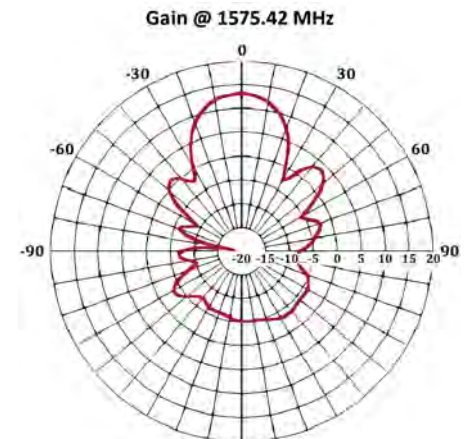
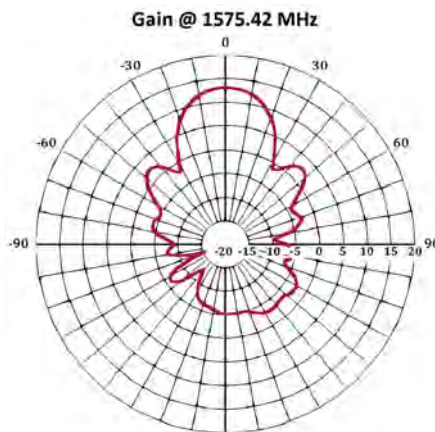

*HE-238-13 antennas installed on a dual-tower mount. The HE-238 antennas have proven their reliability in remote, outdoor locations.*





# HE-238-165-HH Direction Finding Antenna

## PERFORMANCE

VSWR (1.2 to 1.6 GHz)

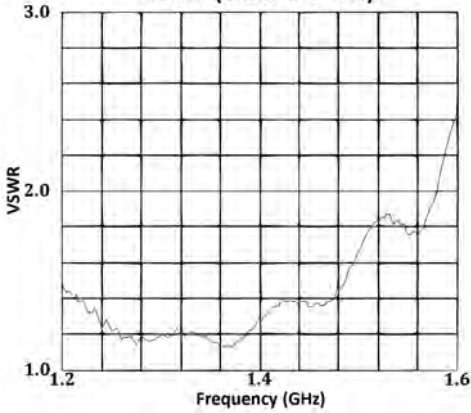

Gain @ 1227 MHz,  $\phi=0$

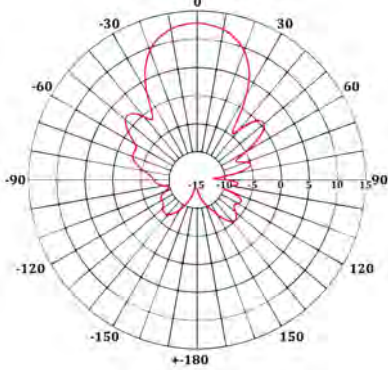

Gain @ 1227 MHz,  $\phi=90$

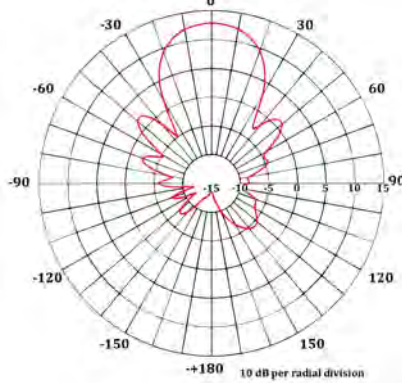

Gain @ 1575 MHz,  $\phi=0$

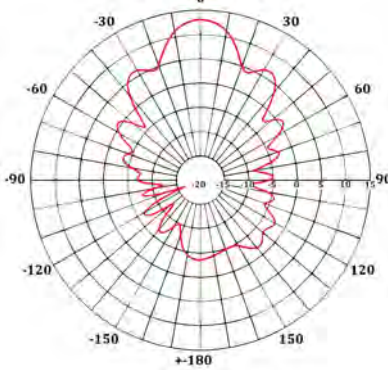

Gain @ 1575 MHz,  $\phi=90$

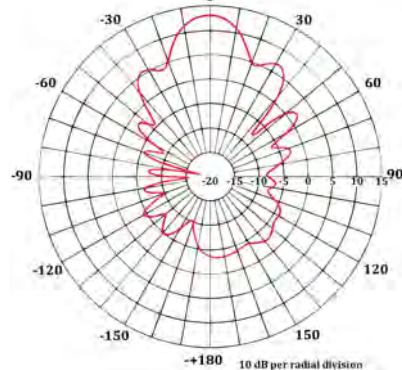

The HE-0238-165-HH is a handheld direction-finding antenna. Used by multiple government entities, this antenna is constructed entirely out of aircraft certified 6061-T6 aluminum and G-10 fiberglass within a 100% sealed radome that will provide many years of quality and reliable service in the field. Previous models have achieved a 2:1 VSWR across the band. Antennas come packaged with shoulder straps and a mounted magnetic compass.



## SPECIFICATIONS

FREQUENCY	1.2 to 1.6 GHz
GAIN	15 dBi (@ $F_0$ )
POLARIZATION	RHCP
HPBW	27° (@ $F_0$ )
MAX. POWER	Receive only
MAX. VSWR	2:1 max.
CONNECTOR	Type-N (female)
DIMENSIONS	7" x 35"
WEIGHT	5.25 lbs

ANTENNAS  
Directional Antennas

# HE-500-10 Helical Antenna

## PERFORMANCE

VSWR (584 to 876 MHz)

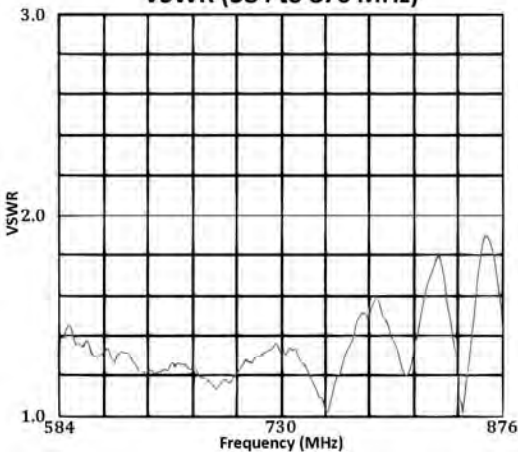

The HE-500-10 is a high-power right-hand circularly polarized (RHCP) communications antenna. The goal in designing this device was to produce an antenna that would be electrically superior and extremely rugged.

These antennas are custom matched from 584 to 876 MHz to achieve a 1.5:1 VSWR across the band. The final design is a high quality product that will provide years of performance in any environment. Mounting hardware is provided with the HE-500-10 to securely fasten the antenna to a 2" diameter pipe.



## SPECIFICATIONS

FREQUENCY	584 to 876 MHz
GAIN	12 dB
POLARIZATION	RHCP
HPBW	35°x35°
MAX. POWER	500 Watts CW
MAX. VSWR	1.8:1
CONNECTOR	Type-N
DIMENSIONS	12" w x 39" l
WEIGHT	15 lbs.



### HE-580-10 Small Helical Antenna

The HE-0580-10 is a high-power, right-hand circular-polarized (RHCP) heavy duty small antenna that can suit both commercial and military applications. The antenna is constructed entirely of aircraft certified 6061-T6 aluminum and G-10 fiberglass with a copper radiator which is all enclosed in a sealed radome. This will ensure the antenna provides many years of quality service. In addition, these antennas are manually matched to achieve a low 2:1 VSWR across the 5.0 to 6.0 GHz band.

#### SPECIFICATIONS

FREQUENCY	5.0 to 6.0 GHz
GAIN	11.75 dBiC (F <sub>0</sub> )
POLARIZATION	RHCP
HPBW	35° x 35° (f <sub>0</sub> )
MAX. POWER	200 W, CW
MAX. VSWR	1.8:1 max.
CONNECTOR	Type N (female)
DIMENSIONS	5.0"(l) x 4.0"(dia.)
WEIGHT	0.5 lbs

#### PERFORMANCE

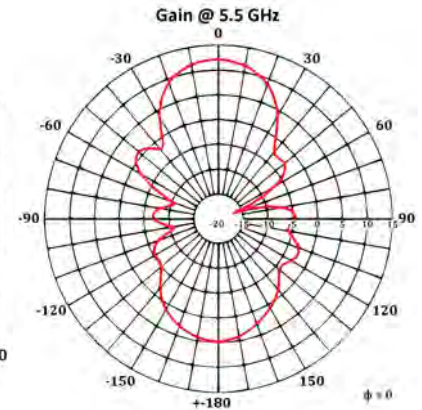
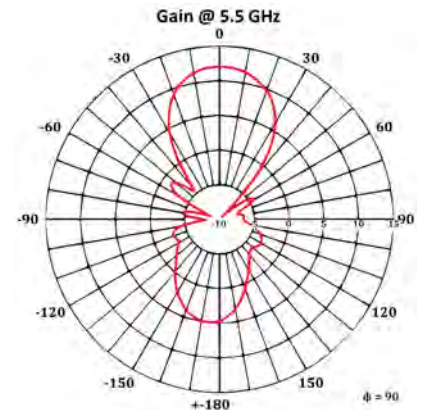

#### FEATURES

- Made for high-frequency operation
- Very small physical footprint

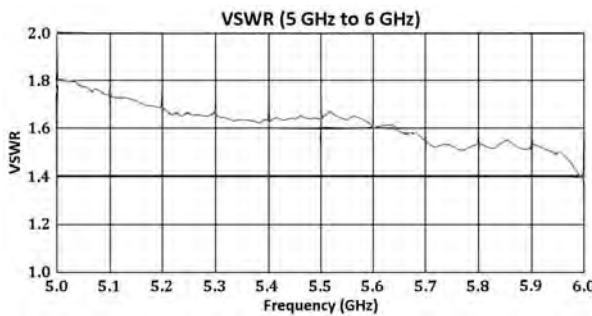

### HE-1000 Series Helical Antennas



The HE-1000 series antennas are high-power, wide band, severe-duty antennas that can serve in both military and commercial applications. The antennas are constructed entirely of aircraft certified 6061-T6 aluminum with copper radiators all enclosed in 100% sealed radomes.

Multiple HE-1000 antennas have previously been used in arrays to increase beamwidth without sacrificing directivity.

The HE-1000 models are currently in use by several U.S. military installations in remote locations due to the years of proven, trouble-free service that these antennas can provide.

#### HE-1000-EC SPECIFICATIONS

FREQUENCY	225 to 400 MHz
GAIN	10 dB
POLARIZATION	LHCP or RHCP
HPBW	45°
MAX. POWER	1000 W
MAX. VSWR	1.9:1 max
CONNECTOR	N, HN or LC
DIMENSIONS	50" x 28"
WEIGHT	43 lbs

#### HE-1000-10 SPECIFICATIONS

FREQUENCY	230 to 360 MHz
GAIN	10 dB
POLARIZATION	RHCP
HPBW	45°
MAX. POWER	1000 W
MAX. VSWR	1.5:1 max
CONNECTOR	N, HN or LC
DIMENSIONS	52.68" x 30.00"
WEIGHT	45 lbs

#### PERFORMANCE

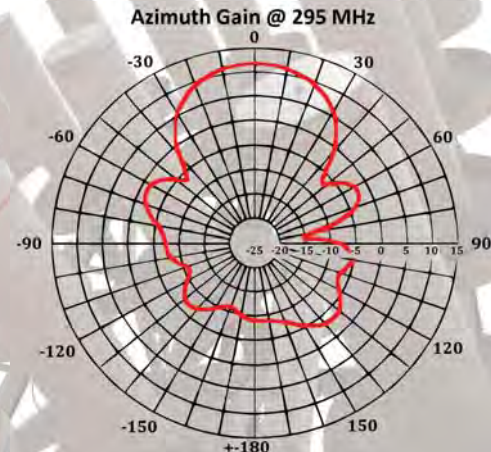
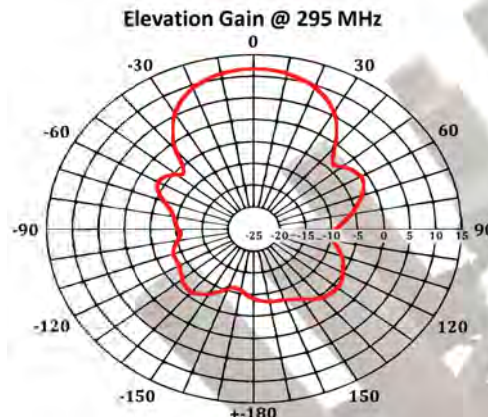
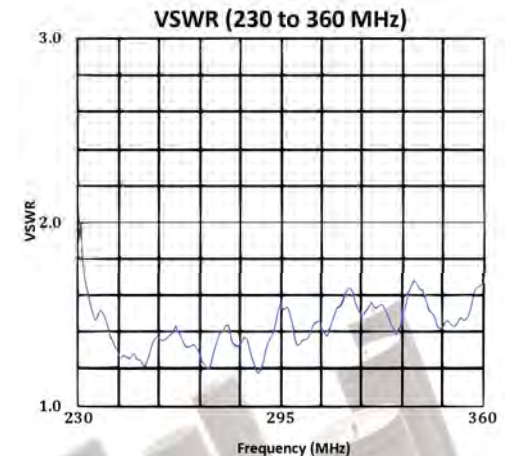

## HO-90-24 Horn Antenna

### FEATURES

- High frequency antenna (8 to 12 GHz)
- Highly directive, narrow beamwidth
- Constructed with 6061-T6 aluminum

The HO-90-24 antenna is a small, high-power directional antenna that covers the 8.2 to 12.4 GHz range. The operating frequency of this antenna make it ideal for RADAR, motion detection, space/satellite communication and amateur radio applications.

### PERFORMANCE

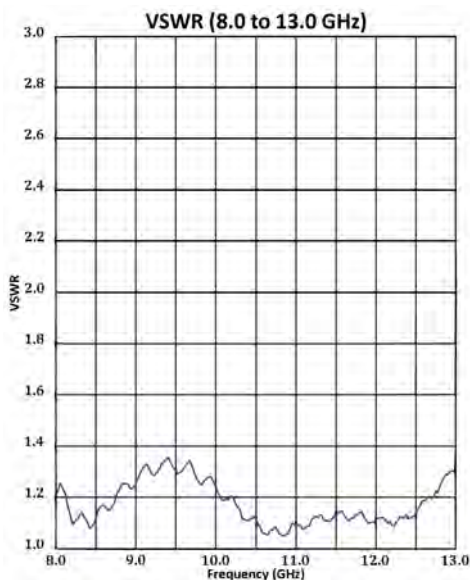
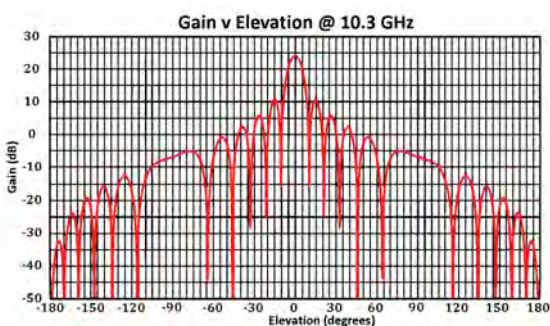
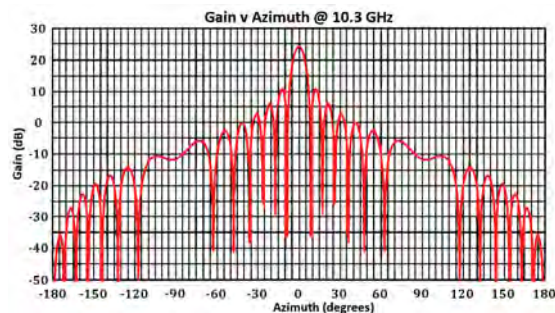

### SPECIFICATIONS

FREQUENCY	8.2 to 12.4 GHz
GAIN	24 dBi
POLARIZATION	Linear
HPBW	10° x 10°
MAX. POWER	50 watts, CW
MAX. VSWR	1.5:1.0
CONNECTOR	Type SMA
DIMENSIONS	6" x 8.5" x 20.5"
WEIGHT	2 lbs

## HO-112-RH Reduced Height Horn Antenna

### FEATURES

- Usable in high-frequency applications
- Small physical profile
- Possible applications include terrestrial broadband, speed detection, motion detection, traffic control, RADAR, weather monitoring and amateur radio.
- Lightweight
- Durable construction
- High-power horn antenna
- Additional waveguide mating options available

The HO-112-RH horn antenna operates from 7 to 10 GHz. The antenna has is specifically designed with a small physical footprint for use in applications where space considerations are a factor.

### PERFORMANCE

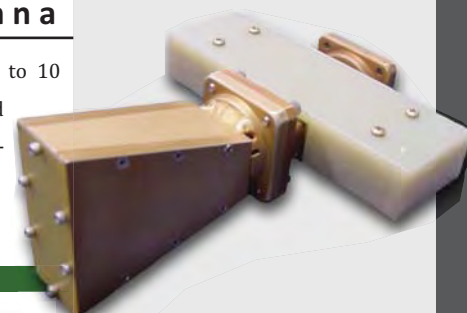
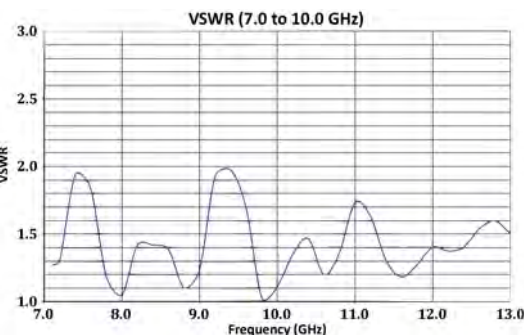
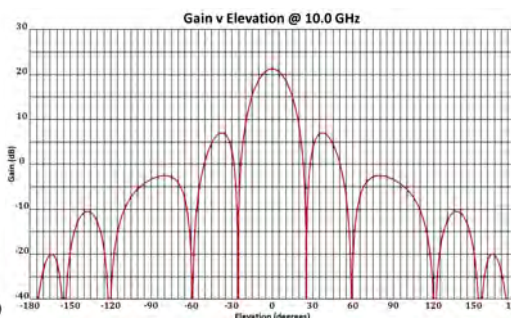
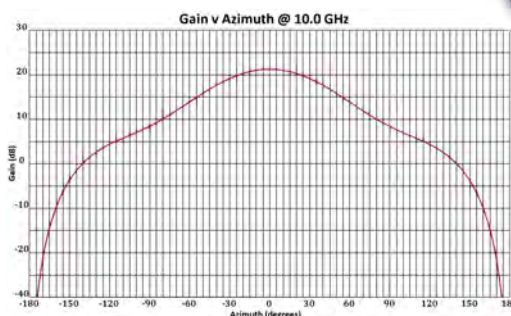

### SPECIFICATIONS

FREQUENCY	7.05 to 10.0 GHz
GAIN	8 dB
POLARIZATION	Linear (Vertical)
HPBW	30° x 120°
MAX. POWER	100 KW
MAX. VSWR	1.8:1
CONNECTOR	WR-112
DIMENSIONS	7.25" x 2" x 3"
WEIGHT	1.1 lbs

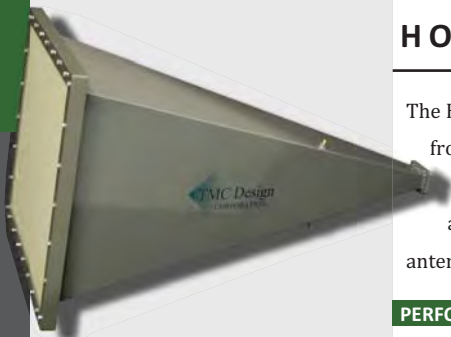

## HO-284-24 Horn Antenna

The HO-284-24 is a mid-size horn antenna that operates from 2.6 to 3.9 GHz. Contact a TMC Design representative for a details on mounting solutions that are available for proper setup of this medium sized antenna.

### FEATURES

- Ideal for use in UHF-band related applications; television, mobile phone, two-way radio, GPS, IEEE 802.11 technology, amateur radio and ground penetrating RADAR
- Exceptional gain
- Durable construction
- Qualified for high-power application
- Highly directive, narrow beamwidth
- Tower, tripod and other mount options available
- Several mating options available

### PERFORMANCE

#### SPECIFICATIONS

FREQUENCY	2.60 to 3.95 GHz
GAIN	24 dBi @ $f_0$
POLARIZATION	Linear
HPBW	9° x 8°
MAX. POWER	3 MW, .1% DC
MAX. VSWR	2:1
CONNECTOR	Open-ended waveguide
DIMENSIONS	22"x26"x47"
WEIGHT	80 lbs

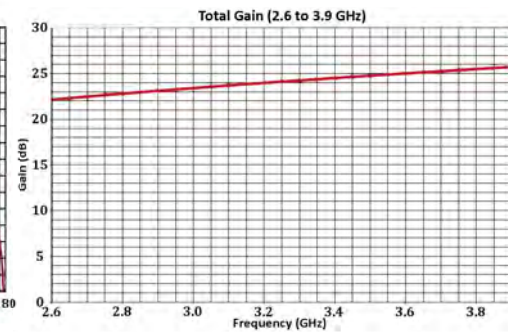
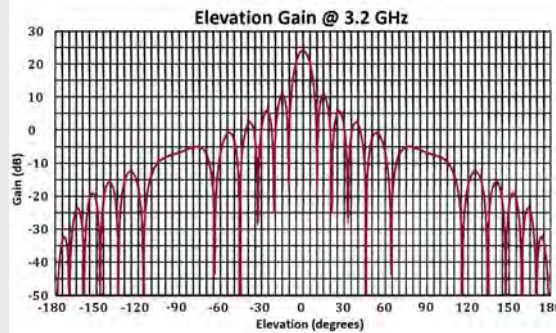
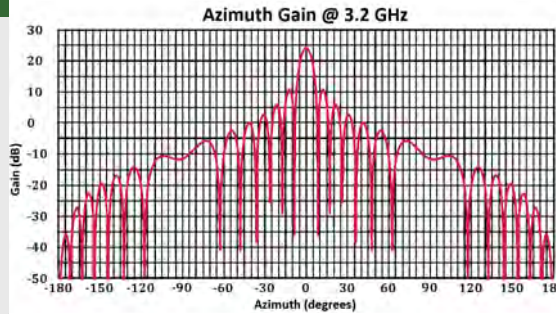

## HO-430-10-HH Direction Finding Antenna



The TMC HO-430-10-HH antenna is the latest addition to our hand held, direction-finding (DF) antennas. This S-Band DF antenna is ideal for testing or real-life DF scenarios. The antenna is mounted on two ergonomic grips for easy handling and quick results.

### FEATURES

- Used for receive-only direction finding applications
- Ergonomic handles for secure grip and easy handling
- Weight (4 lbs) optimizes handling and usability
- Useful in S-band-related applications

#### SPECIFICATIONS

FREQUENCY	25 to 1000 MHz
GAIN	-3dB avg.
POLARIZATION	RHCP
HPBW	360° x 85°
MAX. POWER	Receive only
MAX. VSWR	3:1
CONNECTOR	Type N (female)
HEIGHT	12.7"
DIAMETER	3"
WEIGHT	4 lbs

### PERFORMANCE

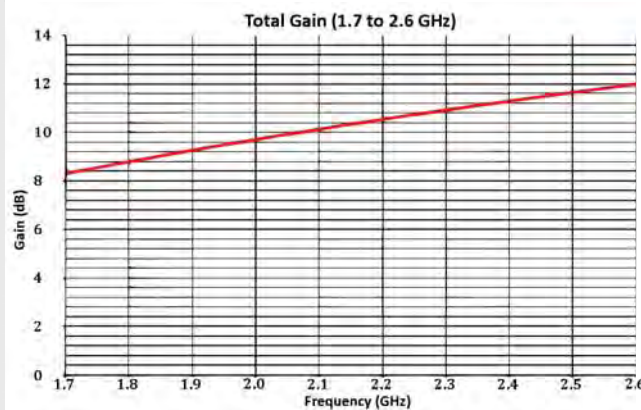

## HO-430-18 Horn Antenna



### FEATURES

- Narrow beamwidth
- High gain
- Useable in high-power applications
- Lightweight
- Optional mount & mating options available

The HO-430-18 is a medium-sized, high-power horn antenna designed to operate from 1.7 to 2.6 GHz; ideal for point-to-point communications within the UHF frequency band.

### PERFORMANCE

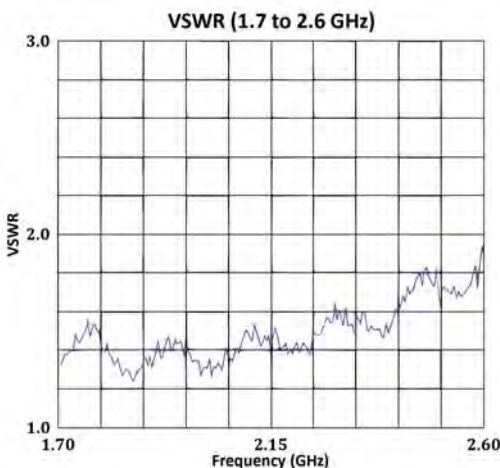
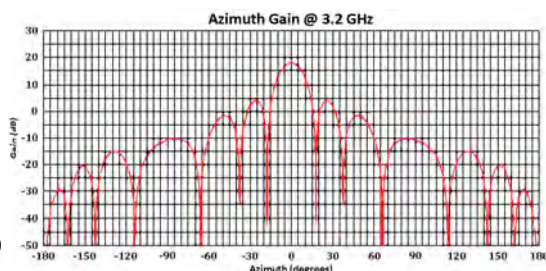
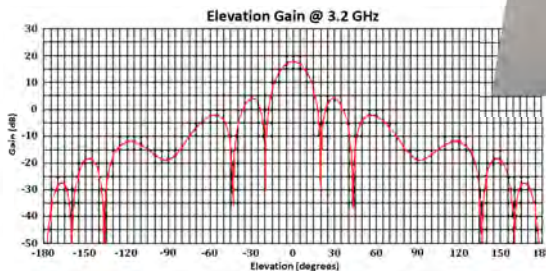

### SPECIFICATIONS

FREQUENCY	1.7 to 2.6 GHz
GAIN	18 dBi, typ.
POLARIZATION	Linear
HPBW	20°
MAX. POWER	1000 W, CW
MAX. VSWR	2:1
CONNECTOR	Type N (female)
DIMENSIONS	16"x18"x30"
WEIGHT	4 lbs

## HO-430-24 Horn Antenna

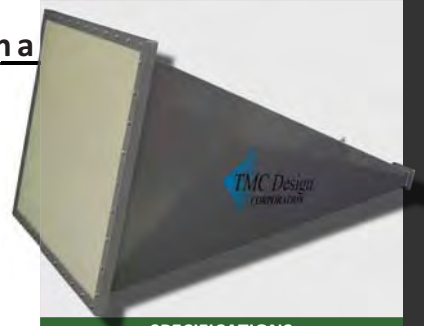

### FEATURES

- Operates within the UHF frequency band
- Applicable uses include television, broadcast translation, radio, wireless networking, cell-phones and GPS
- Narrow beamwidth
- 24 dB gain
- Applicable for high-power applications
- Optional mating options available (antenna delivered with open-ended waveguide connection)
- Delivery service available for mounting and installation assistance
- Horizontal & Vertical linear polarization available

The HO-430-24 antenna is a large, high-power antenna that is design to perform at frequencies from 1.7 to 2.6 GHz.

Mounting and installation should be thoroughly considered for this 6' antenna. Contact a TMC Design sales representative for possible mount solutions and installation services that are available.

### PERFORMANCE

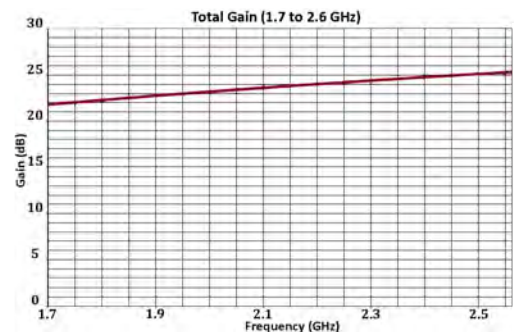
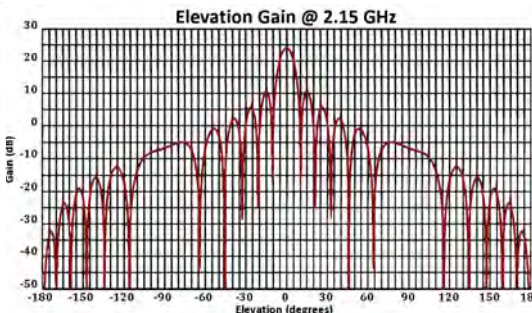
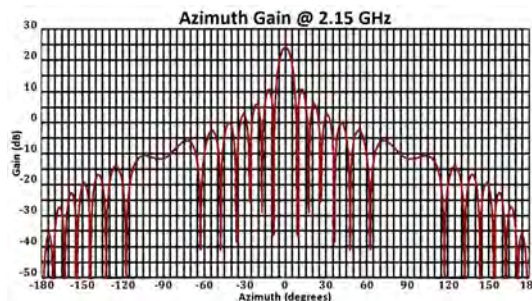

### SPECIFICATIONS

FREQUENCY	1.7 to 2.6 GHz
GAIN	24 dBi @ f <sub>0</sub>
POLARIZATION	Linear
HPBW	10.5° x 9.0°
MAX. POWER	3 MW, 0.1% DC
MAX. VSWR	2:1
CONNECTOR	Open waveguide
DIMENSIONS	72.0"x39.5"x34.0"
WEIGHT	230 lbs



**SPECIFICATIONS**

FREQUENCY	1.12 to 1.7 GHz
GAIN	20 dBi, typ.
POLARIZATION	Linear
HPBW	15°
MAX. POWER	500 W, CW
MAX. VSWR	2:1
CONNECTOR	Type N (female)
DIMENSIONS	36.0"x38.5"x58.5"
WEIGHT	47 lbs

**HO-650-20 Horn Antenna**

The HO-650-20 is a large horn antenna designed to operate in the 1.12 to 1.70 GHz range.

**FEATURES**

- Operates within the UHF frequency band
- Applicable uses include television, broadcast translation, radio, wireless networking, cell-phones and GPS
- Narrow beamwidth and bandwidth
- 20 dB gain
- Delivery service available for mounting and installation

**PERFORMANCE**

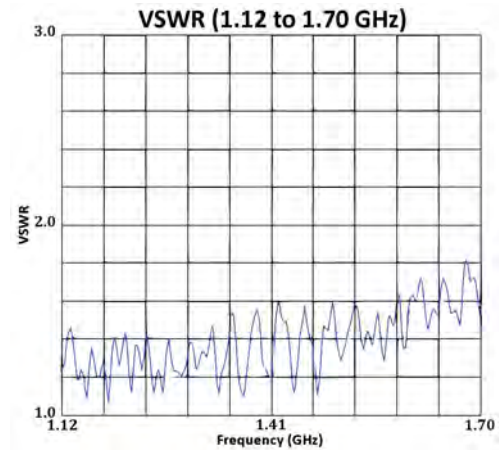
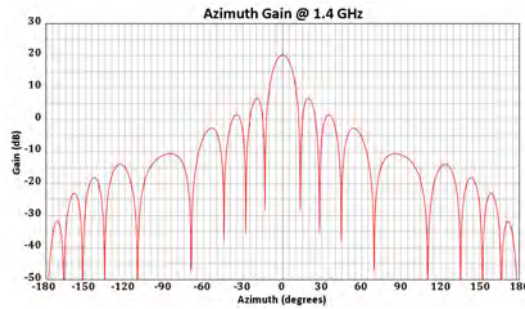
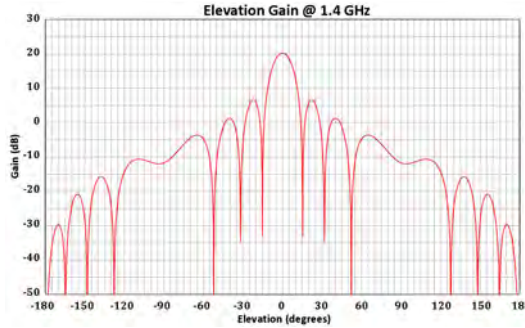

**SPECIFICATIONS**

FREQUENCY	1.12 to 1.70 GHz
GAIN	24 dBi @ f <sub>0</sub>
POLARIZATION	Linear
HPBW	11° x 9.8°
MAX. POWER	3 MW, 0.1% DC
MAX. VSWR	2:1
CONNECTOR	Open waveguide
DIMENSIONS	105"x60"x51"
WEIGHT	320 lbs

**HO-650-24 Horn Antenna**

The HO-650-24 is a large horn antenna designed to operate in the 1.12 to 1.70 GHz range. The antenna is over 8 feet at its prime dimension and weighs 320 lbs. Contact a TMC Design representative for a details on mounting solutions that are available for proper setup of an antenna of this stature.

**FEATURES**

- Specializes in the UHF frequency band
- Applicable uses include fixed maritime, aeronautical and space communications and radio broadcast.
- Qualified for high-power applications
- Relative narrow beamwidth and bandwidth
- 24 dB gain
- Horizontal and vertical linear polarizations available
- Delivery service available for mounting and installation
- Trailers available for mobile communications

**PERFORMANCE**

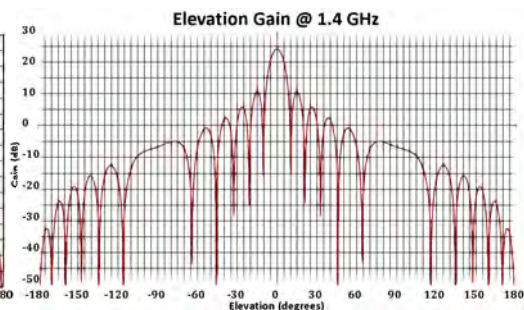
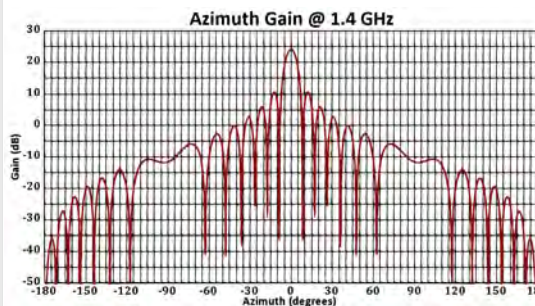
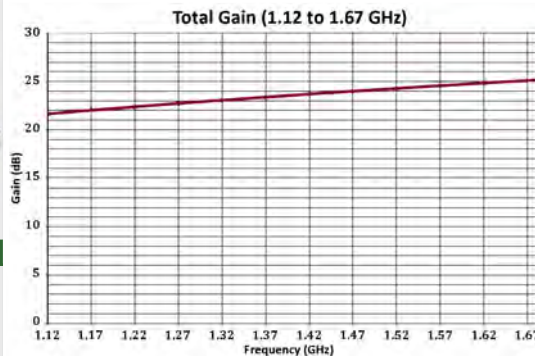



The HO-1200-15, HO-2450-15 and HO-4925-13 horn antennas operate from 150 to 940 MHz.

The low frequency capability of these antennas consequently determines their large physical profile. To mitigate handling issues inherent with such large, cumbersome antennas they have been designed to function with ruggedized, military-grade trailers for easy positioning and maneuverability.

The inclusion of a trailer provides a platform for incorporating operational enhancements to the antenna. The trailers allow the antenna to be trans-

ported over roads and highways at speeds up to 55 MPH. Four (4) stowable stabilizer jacks on the trailer ensure a level and proper position during system operation. An integrated rotary system is also included that will re-position the antenna for vertical or horizontal polarized transmissions. In addition, all trailer models come with weather-proof storage cases with 24.5 ft<sup>3</sup> carrying capacity.

**HO-1200-15 SPECIFICATIONS**

FREQUENCY	615 to 940 MHz
GAIN	15 dBi @ 770 MHz
POLARIZATION	Linear
HPBW	30 x 30°
MAX. POWER	15 kW, CW
MAX. VSWR	1.6:1
CONNECTOR	3 1/8" EIA Flange
DIMENSIONS	44"h x 44"w x 37"l

**HO-2450-15 SPECIFICATIONS**

FREQUENCY	301 to 460 MHz
GAIN	15 dBi @ 380 MHz
POLARIZATION	Linear
HPBW	30 x 30°
MAX. POWER	15 kW, CW
MAX. VSWR	1.6:1
CONNECTOR	3 1/8" EIA Flange
DIMENSIONS	63"h x 69"w x 58"l

**HO-4925-13 SPECIFICATIONS**

FREQUENCY	150 to 229 MHz
GAIN	13 dBi @ 190 MHz
POLARIZATION	Linear
HPBW	43.6° x 43.7°
MAX. POWER	15 kW, CW
MAX. VSWR	1.6:1
CONNECTOR	3 1/8" EIA Flange
DIMENSIONS	83"h x 96"w x 80"l

**FEATURES**

- 15-minute setup time
- Very-low frequency operation
- Applicable uses include fixed maritime, aeronautical and space communications and radio broadcast
- Qualified for high-power applications
- Stabilizer jacks with levels for accurate setup
- Capable of both vertical and horizontal linear polarization
- Capable of travel on gravel and unproved roads
- Highway travel up to 55 MPH
- Heavy Duty Torsion Axles, 6000 lb capacity
- CARC & powder coat finish
- Anti-skid trailer surface
- Heavy Duty Torsion Axles, 6000 lb capacity
- Weatherized for wind, ice, rain and extreme temperature conditions



The low-frequency horn trailer rotary systems allow antennas to operate in vertical or horizontal polarization.

# CUSTOM ANTENNAS & PROJECTS

Our goal is total customer satisfaction. If your unique application requires a specialized antenna, not listed in this catalog, our engineers will help you develop a solution. In addition, the form and function of any catalog antenna can be modified in any manner that best fits your needs.



Combat TELS Multi-phase Antenna Array

## Multi-Phase Antenna Array

The Telemetry Spigot Multi-Phase Solid-State Array (*shown above*) is a unique receive-only antenna array that allowed operators simultaneous reception of up to three (3) geo-synchronous satellites within  $\pm 45$  degrees Azimuth and  $\pm 2$  degrees Elevation of each other.

Anticipating heavy wind conditions at the customer's installation site, the antenna system was designed with an adjustable wide-leg tripod base. The tripod can be adjusted in Azimuth and Elevation ( $15^\circ$ ) directions after the system is setup.

## Environmental Electromagnetic Link Protection System

The Environmental Electromagnetic Link Protection Systems were developed to satisfy a customer requirement to detect Radio Frequency Interference (RFI) in the S-band Space-Ground Link Subsystem (SGLS; 2200 to 2300 MHz). The result is a system that effectively detects RFI from either ground based or low altitude signal sources. Once detected the system is capable of saving and reporting:

- the reference time of occurrence,
- duration of occurrence,
- the direction of the interfering source,
- the measured impact on a downlink signal.

Multiple systems have been procured by the US Air Force and are currently operating at eight of their facilities all over the world. Many of the systems that were deployed were uniquely designed to cope with the environments and circumstances of their installation sites such as outdoor operation, wind resistance, waterproofing and sub-zero operation. Systems included a slotted waveguide antenna mounted on a 360 rotating pedestal mount and an equipment rack with telemetric hardware.

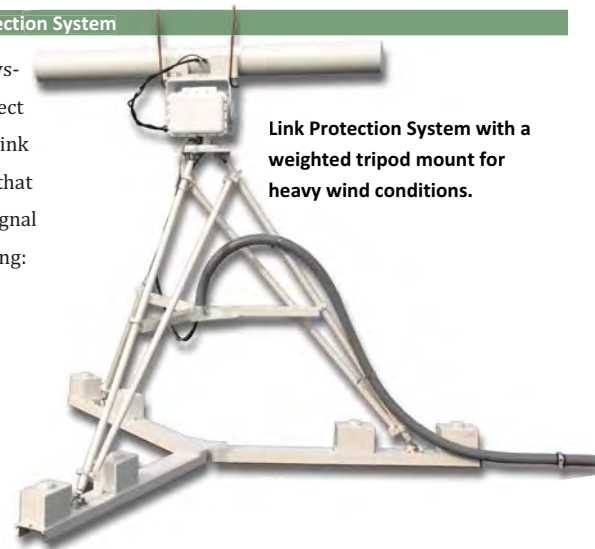

Link Protection System with a weighted tripod mount for heavy wind conditions.

Link Protection System shown mounted on a customized tower mount.

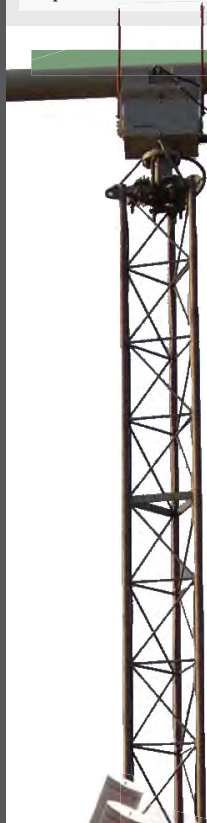

## Red Yak Antenna Array

The Red Yak system was developed to emulate a foreign threat to serve as a training aid for the SATCOM community.

The Red Yak system utilizes two (transmit/receive) antenna trailers, bearing a 4x4 HE-1000 antenna array, and two semi-transportable command shelters.







*Micro-GPS Jamming (MGJ) system*

## EW SYSTEM MODELS

TMC Design Corporation is a supplier of high quality Electronic Warfare systems for the U.S. Air Force, U.S. Army and U.S. Navy. Our GPS jamming systems are used by all JPO-approved exercises where certified systems are required. Whether you need a single high-quality, mil-spec EW system or a thousand a month, Our facilities are ready to meet your EW needs.



### Signal Modulators

Modulator systems are capable of varying the amplitude, frequency, or phase of a generated RF signal. The flexibility of such systems make them ideal for use as threat representatives in equipment test and evaluation applications. TMC Design offers systems capable of analog and digital modulation.



### Signal Jammers (EW)

Signal jammers are capable of disrupting wireless signals. These devices can be used as threat representatives for test and evaluation of RF-based systems or provide your facility, equipment or personnel with protection from unwanted communications or electronic attacks.

Model	Function	Application	
WBJ	Jammer	EW	See p26
TAVIA	Modulator	Testing	See p27
MGJ	Jammer	EW, testing	See p27
TATE V2	Modulator	Testing	See p28

# Wireless Bomb Jammer (WBJ)



WBJ v1



WBJ v2

WBJ v3

Kits are also available for upgrade or modifications of existing WBJ units.

TMC Design offers a variety of Wireless Bomb Jammers which provide proven protection against current threats for single vehicle applications. Units outfitted in every vehicle will provide coverage for large convoys and smaller two (2) or three (3) vehicle parties.

WBJ devices are inexpensive, easy to assemble and quick to deploy. WBJ protects against the latest threats and is field programmable to ensure protection against tomorrow's threats.

Ordered systems can be factory-modified to operate with specifications that best fit customer requirements. Modifications can include an expanded threat handling capability (GPS, sawtooth & H2K) and added power for extra coverage.

All orders come with an I/O box power plug, power cable, communications cable, documentation, operating software and Omni-directional EW antenna.

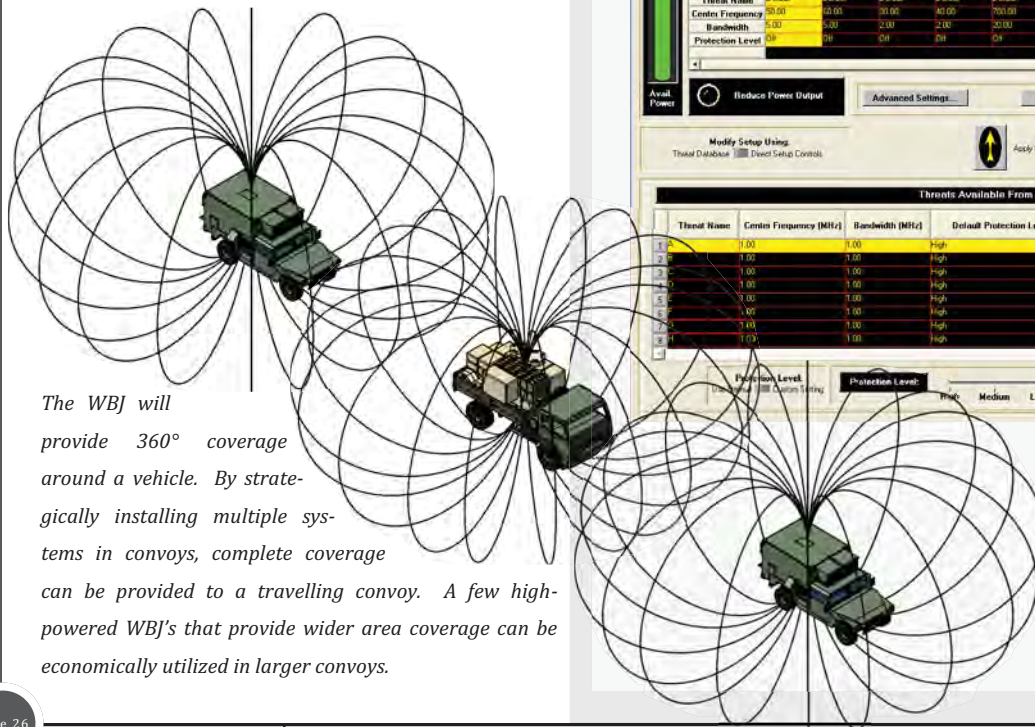

The WBJ will provide 360° coverage around a vehicle. By strategically installing multiple systems in convoys, complete coverage can be provided to a travelling convoy. A few high-powered WBJ's that provide wider area coverage can be economically utilized in larger convoys.

## FEATURES

- Customizable, optional modules available for UHF, VHF, HF, L and S Bands
- Active jammer with continuous or hop operation modes
- 8 analog spots each adjustable in frequency, bandwidth & power level
- 40 digital spots with multiple digital modulations
- All standard low power and all high power (H2K) threats
- Modifiable amplifier adjusts output
- Rugged Design (Mil-Std-810F tested for mobile environments)
- Fully field programmable from a laptop (software provided)
- Easy installation /operation
- Discreet appearance, once installed
- WBJ can be expanded / upgraded to combat the latest threats
- Preserves blue force communications



The intuitive WBJ setup software allows users to setup, calibrate and test units before deployment. All that is needed to use the software is a laptop computer and an RS-232 communications cable.

## Micro GPS Jammer (MGJ)

### FEATURES

- The MGDS has two RF outputs for simultaneous broadcast at the 1575 & 1227 MHz GPS Range.
- Unit is fully field programmable with a laptop via an RS-232 communication port
- An MGDS unit is capable of operating for up to 15 hours when connected to a 45 A/h battery.
- System can be customized to handle an even wider variety of threats.

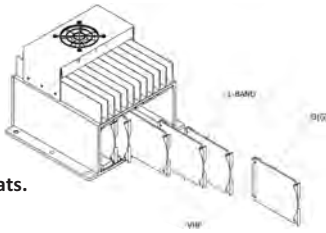

The MGJ is an EW Jammer created specifically for GPS systems. The unit uses active EW jamming and deception techniques to prevent adversaries from effectively operating GPS systems. It has been designed for use as a transportable system, resulting in a product that is lightweight, portable and robust.

### SPECIFICATIONS

CARRIER FREQUENCY	1575 Mhz & 1227 MHz
WORKING VOLTAGE	9 to 36 V
CURRENT DRAW	3A @ 12V
POWER OUTPUT	0 dBm
MODULATIONS	CW, SAW, Noise & BPSK
DIMENSIONS	9"x11"x13"
WEIGHT	15 lbs



MGJ

### MICRO GPS DENIAL SYSTEM

The MGDS is also available as a complete EW-GPS combat system centered around TMC Design's MGJ unit. In addition to the GPS jammer, this system package includes four (4) antennas that operate within the GPS frequency range and a quick-deploy tower for rapid site setup & teardown for mobility requirements.

- 1 x Micro GPS Jammer
- 2 x FS-1050 1.2 to 1.6 GHz antennas
- 2 x DS-300 1.2 to 1.6 GHz antennas
- 1 x 800 Series Quick Deploy Tower (QDT-800)

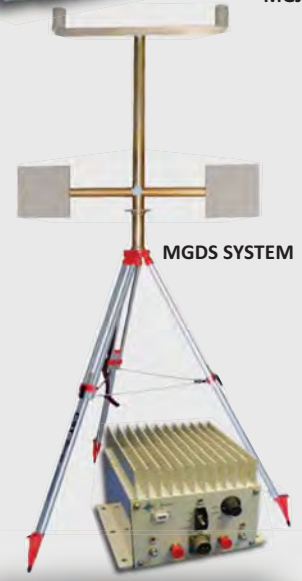

MGDS SYSTEM

## TAVIA-32

The TAVIA-32 Emulator is a highly flexible RF source designed to allow reproduction of EW bi-phase frequency shift keyed pulse modulation Gold Codes techniques. The modulator can pulse on and off to precisely emulate the duty cycle and modulation of threat systems (as verified by NAIC).

able at 19" (therefore, highly transportable).

TMC Design's goal during design and fabrication of this system was to produce an EW modulator that is a verified modulation source, highly reliable and rack mount-

The system chassis is constructed from aircraft quality aluminum and assembled with stainless steel hardware. Features include operation that exactly emulates the threat system without additional frequencies that can cause great difficulty obtaining frequency clearance. The unit can be provided as a modulator or with a variety of amplifier options.



TAVIA

### TAVIA SYSTEM

The TAVIA System also is available as a complete EW-GPS threat emulation system. This package includes a TAVIA-32, four (4) antennas that operate within the GPS frequency range and a quick-deploy tower for mobility requirements. This system is available in 0, +40 and +47 dBm output power models.

- 1 x Amplified TAVIA Modulator
- 2 x FS-1050 1.2 to 1.6 GHz Antennas
- 2 x DS-300 1.2 to 1.6 GHz Antennas
- 1 x QDT-800 Quick Deploy Tower

### SPECIFICATIONS

OPERATING FREQUENCY	1227.6 and 1575.4 MHz
STABILITY	±10 KHz after 2-min warm-up
NO. OF CHANNELS	2 (L1 & L2)
RF MODES	Gold Code
BLINK MODES	Variable duration & period
OUTPUT BANDWIDTH	2.048 KHz
BPSK MODULATION	All 32 Gold Codes
OUTPUT POWER	+0 dBm
DIMENSIONS	19"x16"x3.5"
WEIGHT	12.5 lbs
OPERATING TEMP	0° to 65° C
STORAGE TEMP	-65° to +150° C



TAVIA SYSTEM

# TMC Advanced Threat Emulator Version 2 (TATE II)



## FEATURES

- 960 MHz to 2.0 GHz operating band (expandable to 6.0 GHz)
- 2 independent channels
- Touch Screen LCD interface
- Multiple external interfacing options
- Modulates FM, PM and BPSK (all 32 Gold Codes)
- Saves setup configuration for recall

The TATE V2.0 is a rack-mountable signal modulator that can provide medium power signals for use in electronic warfare (EW) test environments. Features include two independently controlled RF ports with variable output, a resistive touch screen interface and remote controllability. TATE II models that operate from 960 MHz to 6.0 GHz are also available.

The TATE V2.0 is capable of operating with Continuous Wave (CW), Analog Noise, Sawtooth and BPSK under variable settings such as Center Frequency and Attenuation. Under a BPSK the TATE II will modulate any of the 32 GPS Gold Codes.

The TATE V2.0 is designed to be 100% compatible with legacy TATE systems.

## SPECIFICATIONS

FREQUENCY BAND	L-band, 960 MHz to 2.0 GHz (6.0 GHz model available)
TUNING STEPS	≅100 kHz
DYNAMIC RANGE	≅60 dB in ≅1.0 steps
MAX OUTPUT POWER	0 dBm, typical per channel
INPUT POWER	110 VAC, 47-440 Hz, 10 Amp (DC optional)
INTERNAL MODULATORS	<b>FM</b> —Digital sawtooth, 1Hz to 100KHz noise, 10 MHz Gaussian noise <b>PM</b> —1.0 Hz to 1 MHz, 1.0 Hz steps, 1/(2048*PRF) PW <b>BPSK</b> —32 selectable 1024 bit pseudo-random codes, code cycle
MODE DEFINITION	Center frequency; Output power; Digital sawtooth frequency; Pulse repetition frequency; BPSK (all 32 Gold Codes); Pulse width; FM deviation (by noise and/or digital sawtooth)
INTERNAL MEMORY	Non-volatile
USER INTERFACE	LCD Touch Screen
LCD PANEL	25,535 color display, 320 x 270 resolution, 4.5" x 3.5" screen
POWER	ON/OFF toggle switch
OUTPUT CONNECTOR	Type-N
EXTERNAL INTERFACES	EIA-RS-232C, IEEE-488, ENET (per channel; additional interface options available)
MONITOR PORTS	RF monitor, 50 Ohm, BNC, rear panel
OPERATING TEMP	+0° to +50° C (+32° to +120°F)
STORAGE TEMP	-40° to +60°C (-40° to +140°F)
HUMIDITY	0 to 90% Non-condensing



Screenshot of the TATE V2.0 web interface using Mozilla's Firefox Internet browser application. The layout of the web interface is similar to that of the touch-screen interface. Users can also access the web environment using Microsoft's Internet Explorer.

TMC Design specializes in Space Control systems design and production. We offer the latest industry solutions in Offensive Counterspace, Defensive Counterspace and Space Situational Awareness. Many of our space systems are in use at locations around the world. Our Space Operations Center, located in Colorado Springs, CO, is dedicated to providing training, quick reaction support and a hands-on approach for new and existing space systems.

## Defensive Counterspace (DCS)



DCS-related products function to provide protection of space-related resources and capabilities from attacks or interference.

Additionally, DCS equipment can be used to protect space systems from unintentional interference caused by unrelated RF communications and data transmission systems.

## Offensive Counterspace (OCS)



TMC Design OCS products function by neutralizing the resources and capabilities of space systems. This equipment may be

used to test satellite performance during development or operations or to actively and offensively engage a satellite to prevent access to unfriendly users.

## Space Situational Awareness (SSA)



SSA products will provide the user with tactical information required for proper detection, identification and tracking of

artificial objects in Earth orbit. SSA information can be used for the benefit of training exercises, operational missions or testing programs. Typically, SSA systems utilize integrated, state-of-the-art, commercial-off-the-shelf technology similar to mobile satellite broadcast system used by the telecommunications industry.



*Inside the command and control shelter of a Space Situational Awareness system.*

# SATCOM Antenna Controller System

The **Antenna Controller System** contains an equipment suite of the latest satellite communications tools to perform remote tracking, signal testing and signal monitoring functions.

All equipment is contained within a rugged 70" x 33" x 27" container, fitted with a small ECUs for use in extreme and isolated environments.

The system has been designed to simplify setup and configuration. All equipment connections (RF, data and power) are made along the back of the container. Internal can be controlled with a connected PC containing the custom control software.

## SYSTEM FEATURES

### Satellite Tracking

The Antenna Controller System offers two methods for space vehicle tracking. The system can move with the satellite by periodically measuring signal strength or it can move the antenna based on previously saved data (without taking measurements). The Antenna Controller System is also equipped to control motorized antennas for automatic and remote positioning.

### Signal Testing

The system contains a satellite bypass feature that performs L, C, X, Ku and Ka uplink/downlink frequency translation internally. Terminal output from the Antenna Controller System can then be fed to downlink monitoring equipment. This design can be utilized for loop-back testing or any other application that requires minimal amplitude and delay time.

### Signal Monitoring

Monitored events can be recorded through the custom software for post-process analysis and playback.



## SPECIFICATIONS

HEIGHT	33" (max)
WIDTH	70"
LENGTH	27"
ELECTRICAL	110 VAC
RACKSPACE	20 U

## ANTENNA CONTROLLER SYSTEM FEATURES

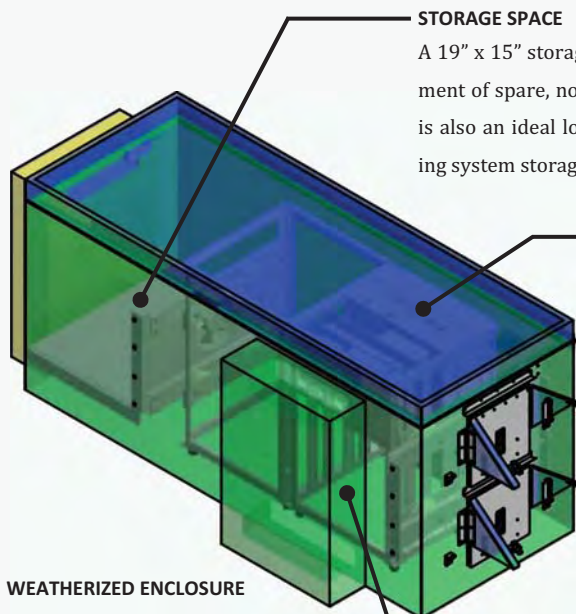

### STORAGE SPACE

A 19" x 15" storage area is available inside the enclosure for placement of spare, non-critical and peripheral equipment. The storage is also an ideal location for communication and power cables during system storage or transport.

### 20U RACK SPACE

The Antenna Controller System houses up to 20U of 19" rack equipment. Equipment can be reconfigured to fit customer requirements.

### WEATHERIZED PASS-THROUGH PANELS

Pass-through panels have been redesigned to allow the system to remain connected and operational in wet, icy and windy conditions.

### WEATHERIZED ENCLOSURE

The entire chassis is 100% sealed to protect from foreign debris. External chassis components are powder coated and CARC painted to provide maximum protection from outdoor elements.

### CLIMATE CONTROLLED ENCLOSURE

The system is equipped with three 5000 BTU air conditioning units, sealed and lined with insulation. With a cooling capability built into the unit, the system can operate for extended periods and remain sealed from outdoor elements.



# Tactical Multiband Antenna Trailer Systems

TMC Design's Tactical Multiband Antenna Trailer Systems are transportable ground-based Space Earth Terminals equipped with the latest in satellite tracking and communication technology. Designed for operation under the military, TMATS is the most rugged answer to the stringent requirements for operation in extreme environments. TMATS systems are currently in use by multiple government entities.

TMATS can be controlled through software for remote operations that allows operators to perform major or minor position adjustments of the pedestal mounted aperture and track satellites through various schemes such as peak-power and programmed tracking.

The antenna system can be built to conform to any military and NATO requirements and be ATTLA-compliant for transport via multi-modal means. The system can be quickly and easily configured.



## FEATURES

- Capable of operating in UHF, S, C, X, K, Ku, Ka and Q Bands
- ATTLA Certifiable for C-17, C-5 and rail transport
- ENET remote controlled with Windows OS Interface
- Ephemeris, TTL, Memory and Power tracking capabilities
- CARC & Powder coat finish
- Anti-skid trailer surface
- Weatherized for wind, ice, rain and extreme temperature conditions
- Heavy Duty Torsion Axles, 6000 lb capacity
- Highway travel up to 75 MPH
- Capable of travel on gravel and unproved roads

## SPECIFICATIONS

FREQUENCIES	UHF, L, S, C, X, Ku, K, Ka and Q bands
POLARIZATION	RHCP
G/T	≥13dB/K
AZIMUTH RANGE	0° to +270°
ELEVATION RANGE	0° to +90° from horizon
WEIGHT	8000 lbs
ELECTRICAL	120 VAC
DIMENSIONS	21.0 ft (l) x 8.5 ft (w) x 9.0 ft (h)
WIND OPERATION	45 MPH (sustained), 60 MPH (gusts)
WIND SURVIVABILITY	100 mph (max., stowed)
RAIN	4 in/hr
SOLAR RADIATION	360 BTU/h/ft <sup>2</sup>
RELATIVE HUMIDITY	100%

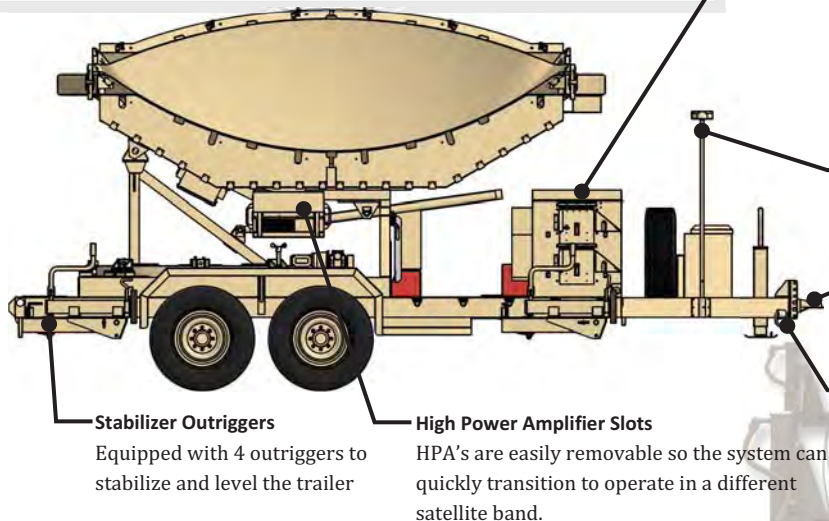

**Weatherized Data Terminal Equipment (DTE) Box**  
The system's DTE box holds the electrical components that control antenna movement and satellite tracking. The system is environmentally controlled and weatherized to protect equipment housed inside it. Depending on the mission and equipment needed the DTE Box is available in two packages; small or large (shown below). The DTE can also be equipped with a backup power system for temporary operation and protection of equipment and data in the event of a power outage.

**GPS System**  
An on-board GPS unit helps the system automatically orient itself for automated satellite tracking

**Tow Attachment**  
An adjustable coupler/pintle allows the system to easily adjust for any towing vehicle.

**20K LB Tie-Downs**  
4 tie-downs on the trailer give the system the capability to withstand forces of up to 4.5 G in the vertical direction

**Stabilizer Outriggers**  
Equipped with 4 outriggers to stabilize and level the trailer

**High Power Amplifier Slots**  
HPA's are easily removable so the system can quickly transition to operate in a different satellite band.

# Space Situational Awareness Systems



Space Situational Awareness (SSA) Systems use the latest in SATCOM hardware to provide quality space communications, testing and analysis capabilities to its users. The tactical information provided by these systems will prove to be an indispensable asset in your SATCOM training exercise, operational mission or test program.

SSA systems use TMC Design's, custom instrumentation, command and control software to communicate with and control all system hardware and instrumentation. Created on a net-centric foundation, the software allows any workstation within an SSA system to control all aspects of the system. The software provides system operators with useful tools that allow users to

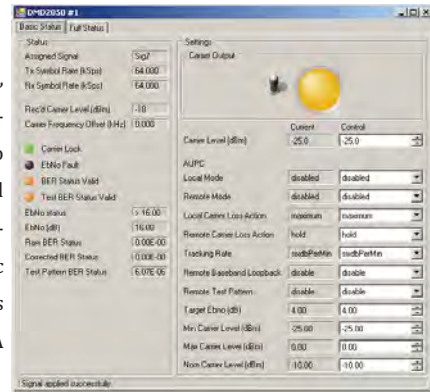

*Control software allows operators to monitor hardware and make configuration changes on the fly. Users will seldom have to leave their workstation to perform front panel configurations.*

make hardware connections and configurations, set up communication links and analyze communication data. The software's simplified user interface and virtual tools provide an engaging and error-free work environment for system operators. In addition to the operational controls, there are many offline tools available to the user for post data analysis.

Our SSA systems are highly customizable. TMC Design can build stationary systems or highly mobile, forward deployable systems, built to suit customer requirements. TMC Design sustainment facilities services are also offered for our SSA systems. Contact us for more information on an SSA systems built to suit your application requirements.

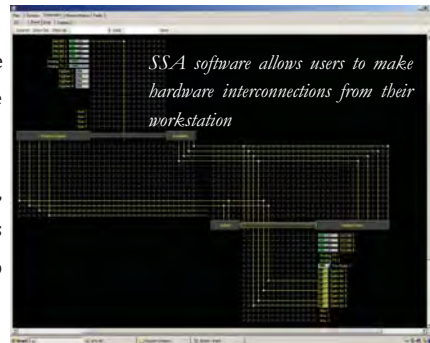

*SSA software allows users to make hardware interconnections from their workstation*

## SPACE SITUATIONAL AWARENESS SYSTEM FEATURES

Typical SSA system configurations will have a Command Center, multiple SATCOM antennas (for simultaneous communication at multiple satellite bands) and support vehicles to serve as power generation stations and supply storage (if the system is mobile).



### MISSION SUPPORT VEHICLES

Mission support systems are available to provide logistical support. Such support services can include offshore / backup power, spare equipment storage and other provisions for extended operation.



### MOBILE COMMAND CENTER

SSA systems typically have a centralized control and command center with multiple workstations. For mobile systems, much of the control equipment is housed inside mobile, climate-controlled shelters.



### SATCOM ANTENNAS

SSA systems typically come with multiple SATCOM antennas for transmit/receive capabilities in one or more bands. For mobile solutions TMC Design can mount the entire SATCOM antenna system on a rugged, towable trailer rated for transport over land, sea and air. See pp. 31 for more information on TMC Design's mobile antenna trailer systems.

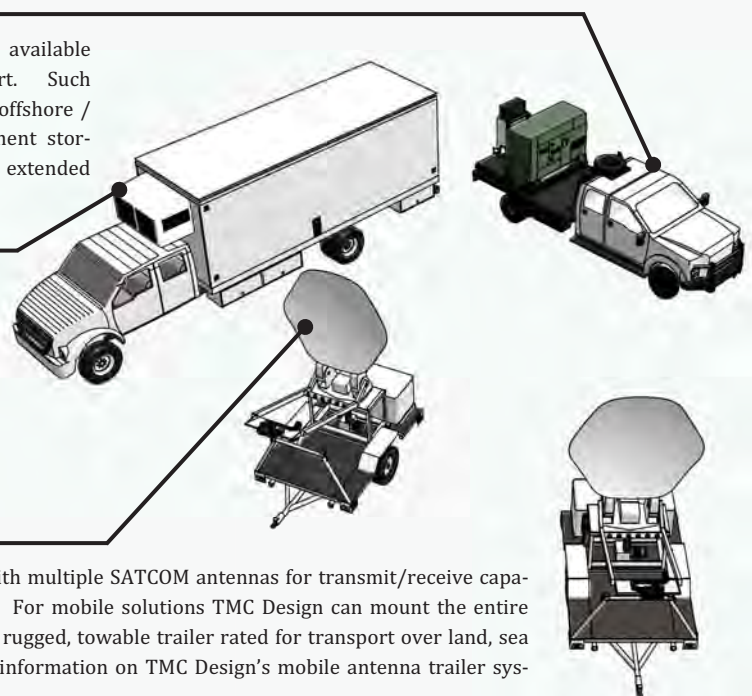



# ANTENNA ACCESSORIES

In addition to the extensive catalog and custom engineering products that TMC Design manufactures, we also provides supplemental equipment to compliment our antennas and electronic systems.

Contact us for pricing on custom accessories not listed in the following pages.



## Box Feeds

TMC Design offers a variety ground and flight based box feeds for use with dish antennas or as gain standards. All feeds are built to be electrically superior and allow for any desired polarization. A custom model can be made to suit.

Model	Operating Frequency (GHz)
BF-675	1.12 to 1.70
BF-550	1.4 to 2.0
BF-475	1.6 to 2.4
BF-375	2.1 to 3.0
BF-350	2.0 to 3.0
BF-275	2.9 to 4.0
BF-225	3.5 to 5.0
BF-175	4.5 to 6.5
BF-162	4.94 to 7.00
BF-150	5.2 to 7.5
BF-125	6.5 to 8.9
BF-100	7.6 to 11.5
BF-075	10.2 to 15.0
BF-062	12.4 to 18.0



## Signal Amplifiers

RF amplifiers increase the power of low to medium-power RF signals for increased coverage, better signal reception or, at minimum, to satisfy power requirements to drive an antenna.

Model	Height (in.)	Weight (lbs)
QDT-800	80	24



## Towers & Masts

Positioning your antenna at a higher elevation can improve coverage and effectiveness of your antenna application. Contact a TMC Design representative to manufacture a tower or mast that best supports your application.

Model	Frequency	Output Power
5063 ART	1.0 to 2.0 GHz	200 W (min.)
TMC-AM-20W	1.2 to 1.6 GHz	20 W
XRF-338	1.0 to 2.0 GHz	100 W (min.)



See p35

See p34

See p35

See p34

*BF-550-72 dish antenna with a BF-550 box feed*



5063-ART shown mounted under a TMC Design LBJ-series EW device

## 5063-ART High Power L-Band Amplifier

The GRF-5063 Hi-Power L-Band Amplifier is a rack-mounted, rugged, solid-state amplifier suitable for Travelling Wave Tube (TWT) replacement in the 800 MHz to 2 GHz range. Designed by OPHIR RF Microwave to TMC Design specifications, this amplifier is 100 % compatible with the TMC Design LBJ and LBS series Electronic Warfare devices. The 5063-ART can

provide 100 watts of output power with any CW, AM, FM, PM or Pulse RF input signal.

This amplifier coupled with TMC Design's modulators and antennas makes a complete test and operational L-Band jamming system to meet or exceed your transmitter specifications.

SPECIFICATIONS		FEATURES	
FREQUENCY	0.8 to 2.0 GHz	• Operates from 8.0 to 2.0 GHz range	• 0°C to +50°C operating temperature
OUTPUT PWR	100 Watts (min.)	• 100 Watts, output power	• 95% non-condensing operating humidity
INPUT PWR	+0 dBm (max.)	• Accepts CW, AM, FM, PM and Pulse RF input formats	• 10,000 ft operating altitude above sea-level
HARMONICS	> 45 dBc	• 1 dB compression at 80 watts	• Shock and vibration-rated for normal truck transport
GAIN	+51 dB	• Harmonics less than 45 dBc at 1 dB compression	• Front panel switch and push-button controls
CONNECTOR	N-type	• Runs on 110 VAC at 10 A, 60 Hz	• Rack mountable
AC POWER	110 VAC	• Thermal overload circuit protection	• 4U rack height
DISPLAY	LCD	• Optional RS-232 or IEE 488 interfaces for remote controllability	
DYNAMIC RANGE	80 lbs		
DIMENSIONS	19"x7"x20"		
WEIGHT	47 lbs		



## XRF-338 High Power L-Band Amplifier

The GRF-5063 Hi-Power L-Band Amplifier is a rack-mounted, rugged, solid-state amplifier suitable for Travelling Wave Tube (TWT) replacement in the 800 MHz to 2 GHz range. Designed by OPHIR RF Microwave to TMC Design specifications, this amplifier is 100 % compatible with the TMC Design LBJ and LBS series Electronic Warfare devices. The XRF-338 can provide 200 watts of output power with any CW, AM, FM, PM or Pulse RF input signal. The unit's physical

profile for mounting in a standard 19" rack enclosure.

This amplifier coupled with TMC Design's modulators and antennas makes a complete test and operational L-Band jamming system to meet or exceed your transmitter specifications.

SPECIFICATIONS		FEATURES	
FREQUENCY	0.8 to 2.0 GHz	• Operates from 8.0 to 2.0 GHz range	• 0°C to +50°C operating temperature
OUTPUT PWR	200 Watts (min.)	• 200 Watts, output power	• 95% non-condensing operating humidity
INPUT PWR	+0 dBm (max.)	• Accepts CW, AM, FM, PM and Pulse RF input formats	• 10,000 ft operating altitude above sea-level
HARMONICS	> 45 dBc	• 1 dB compression at 80 watts	• Shock and vibration-rated for normal truck transport
GAIN	+51 dB	• Harmonics less than 45 dBc at 1 dB compression	• Front panel switch and push-button controls
CONNECTOR	N-type	• Runs on 110 VAC at 10 A, 60 Hz	• Rack mountable
AC POWER	110 VAC	• Thermal overload circuit protection	• 4U rack height
DISPLAY	LCD	• Optional RS-232 or IEE 488 interfaces for remote controllability	
DYNAMIC RANGE	80 lbs		
DIMENSIONS	19"x7"x20"		
WEIGHT	47 lbs		

## TMC-AM-20W Dual Channel 20 Watt Amplifier

### FEATURES

- Designed for use with TMC Design Micro-GPS Jammer (MGJ)
- Dual, independently operated channels
- Covers the 1.2 to 1.6 GHz frequency range (L-band)
- 20 watts output power
- Will continue to operate with power fluctuations ranging from 20 to 28 VDC
- System outputs are protected with circuit applied safeguards to prevent unwanted radiation and damage to system components
- Simple control-switch interface
- Visual indicators present to communicate operating status of each channel.
- Heat transfer & forced air cooled
- Rugged construction
- Quick & easy installation

The TMC-AM-20W Dual Channel Amplifier Module is a 20-watt power amplifier designed to operate in tandem with many of TMC Design's EW systems such as the Micro-GPS Jammer (MGJ, see page 27).

This TMC-AM-20W module contains two RF input channels and two RF output channels that operate independently of each other. The dual channel design corresponds with the output of the MGJ unit, though the TMC-AM-20W will accept any 0 to +6 dBm input RF signal.

A simple front panel interface makes installation and operation straightforward and simple. Simply plug in a power cord the unit is ready for operation. A single, two-position switch at each channel controls its output.

Designed and built to the same standards as our military jammers, the TMC-AM-20W amplifiers possesses the same mobile and temperature environment operating thresholds. As a result, the amplifiers can be installed alongside our jamming systems with no additional, environmentally mitigating accommodations necessary.

Orders also include the RF and power cabling necessary for proper installation to an MGJ unit.

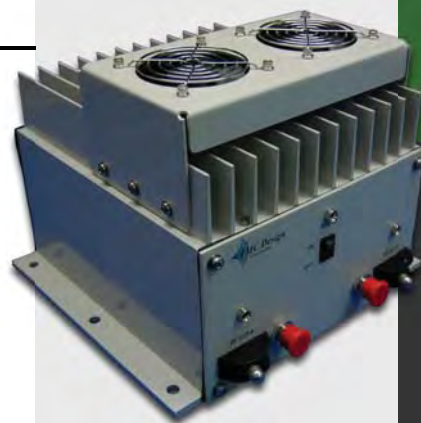

### SPECIFICATIONS

FREQUENCY	1.2 to 1.6 GHz
INPUT PWR	0 dBm to +6 dBm
OUTPUT PWR	20 Watts
VOLTAGE	24 ±4 VDC
DIMENSIONS	13"x11"x9"
CONNECTORS	N-Type

## 800 Series Quick Deploy Towers (QDT-800)

### FEATURES

- Ideal for repeater or jamming applications
- 15-minute setup time
- Mounts up to four antennas at a time
- 72" guy wires provided for added stability
- Handheld leveler provided
- Constructed to aerospace quality standards

The QDT-800 Quick Deploy Tower is a highly portable structure designed to allow for the rapid deployment of mast-mounted repeater or jamming systems. Standard towers will mount four antennas and a repeater antenna on the same mast assembly. Masts can be modified to mount your unique antenna design.

The tower is adjustable to a maximum 6 feet (72 inches) in height and comes with the hardware provisions (level, guy wires & transport container) necessary to ensure proper deployment.

The system is constructed from aircraft quality aluminum, welded by certified welders and assembled using only stainless steel hardware. The result is a ground structure built to aircraft standards that can be used in virtually any environment with little maintenance. Designed and fabricated by TMC Design in Las Cruces, New Mexico, our goal is to produce a system that is structurally superior, easily deployable and low cost.

*QDT-800 mast shown with two DS-0300 and two FS-1050 GPS antennas mounted. QDT-800 masts can be customized to mount your unique antenna design. Contact a TMC Design representative for pricing and information*

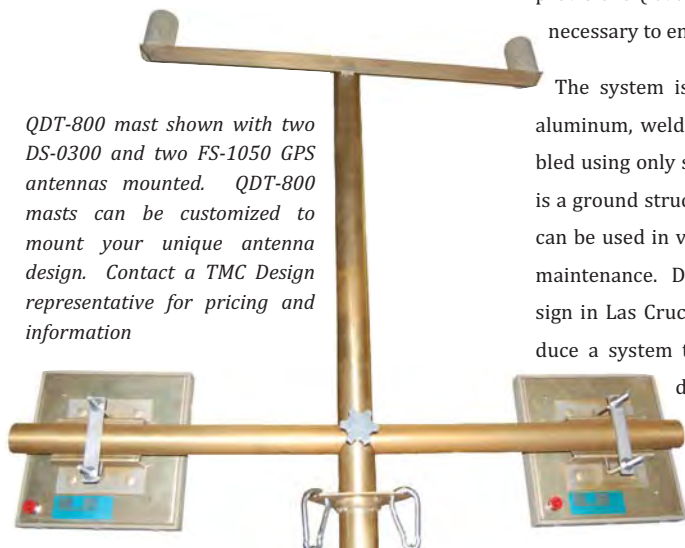

### SPECIFICATIONS

HEIGHT	80"
WIDTH	36"
GUY LENGTH	72"
WEIGHT	8 lbs (tripod) 16 lbs (mast)



# **TMC Design Corporation**

*"Reasonable and timely solutions"*

## **TMC Design Corporation Headquarters**

4325 Del Rey Blvd.  
Las Cruces, NM 88012  
(tel) 575-382-4600  
(fax) 575-523-8588

## **TMC Design Space Planning & Tactics Office**

5030 Bradford Drive  
Building 1, Suite 230  
Huntsville, AL 35805  
(tel) 256-830-4055  
(fax) 256-830-4066

## **TMC Design Space Operations Center**

7765 Electronic Drive  
Colorado Springs, CO 80922  
(tel) 719-622-0130  
(fax) 719-622-0134

[www.tmcdesign.com](http://www.tmcdesign.com)

## **Antenna Design**

Commercial Use  
Military Use  
High-Power  
Wide-Band  
Log-Periodics  
Bi-Conicals  
Horns & Horn Arrays  
Dish Feeds & Dish Systems  
Airborne Certified  
Electrically Small Antennas

## **Systems Engineering**

Electronic Warfare  
Telemetry  
General Purpose Data Acquisition  
Control Systems  
Custom Software

## **Field Support**

Mission Planning  
Integration  
Execution



TMC Design was formed in 1997 by a team of engineers to provide our Government customers the best space control and electronic warfare systems available. During our 13 years of operation TMC Design's customer base has grown to include the Department of Defense (DoD), Department of Energy (DoE) and numerous commercial entities, including Fortune 500 companies. We credit our growing success to our unwavering commitment to providing quality, state-of-the-art and cost effective engineering solutions.