

Field Probe Positioner FSM2315

Technical Data

■ Sensor height (Z-Axis)	between	0.6 ... 2.3 m
■ Horizontal movement (Y-Axis)		1.5 m
■ Permissible load		2 kg
■ Total height		2.5 m
■ Probe fixing		1/4"-20 UNC
■ Materials		Kömacel (foamed plastic), PVC, fiber glass, polyamid
■ Moving speed	max.	12 cm/s
■ Positioning accuracy		± 5 mm
■ Movement of sensor		By Kevlar toothed belts
■ Drive motor		EC motor 150 W (brushless)
■ Operating Voltage		230V AC (50/60Hz) or 110V AC (50/60Hz)
■ Current consumption	max.	1.6 A
■ Power connection		5 m power supply cable with CEE 7/7 plug with integrated filter element
■ Drive unit		shielded and radio interference suppressed max. 5 dB over the chamber background noise
■ Temperature range		+5 °C...+40 °C
■ Control		microcontroller board
■ Control line connection		Fiber-optic duplex (2pcs: 1×5m + 1×10 m incl.
■ Drivable by		CO3000, CO2000
■ Accessories		2pc Aluminum boxes for storing, Service manual
■ Available options:		lowered sensor fixing, flight case for storing/shipping

Brief description

The Field Probe Positioner FSM2315 is a two Axis positioner for continuous or step by step movement like for the field uniformity measurement according to EN61000-4-3 (16-points measurement). The movement range covers an Area of 1.5 x 1.5m.

The structure is easy to disassemble and all parts can be proper stored in two Aluminum boxes (scope of delivery). The assembling needs approx. 15 min so the FSM2315 is convenient to share with related labs and an ideal device for service provider.

The RF-shielded compact drive powered by low current EC motor, with FO control line is to be driven by Controller (like CO3000). Metal parts are used as less as possible and located only in the drive unit (max. 0.27 m above ground level). Limit switches and the proper mechanical design ensure a reliable system operation.

The IEEE 488 (GPIB) bus, when operated with the CO 2000 Controller, or IEEE 488 (GPIB) & TCP/IP (LAN) interface, when operated by CO 3000 Controller provides an additional control option for all functions.



fig. 1: Field Probe Positioner FSM2315 in the 2014 version





KEINE FREIGABE - NOT RELEASED

Revision	Änderung	Datum	Name
03			
02		18.03.2015	MS
01	Explosionsansicht eingefügt	18.03.2015	MS

Diese Zeichnung ist urheberrechtlich geschützt. Kopien, auch auszugsweise, sowie die Weitergabe an Dritte bedürfen unserer ausdrücklichen und schriftlichen Genehmigung.

innco systems GmbH
 Erlenweg 12 • 92521 Schwarzenfeld
 Phone +49 (9435) 301659-0 • Fax -99
 eMail: info@innco systems.com

Masstab:	Sage-Nr.:	Material:
1:15		
		Oberfläche:

	Datum	Name
3D erstellt	31.07.2014	MS
3D Freigabe	18.03.2015	MS
2D erstellt	09.03.2015	MS
2D Freigabe		

Übersicht
FSM zerlegbar

ISYS-0017038	Revision: 4/4
02 03	1 A3
Modell	Zeichnung

ALLGEMEINTOLERANZ
DIN 7168 - m

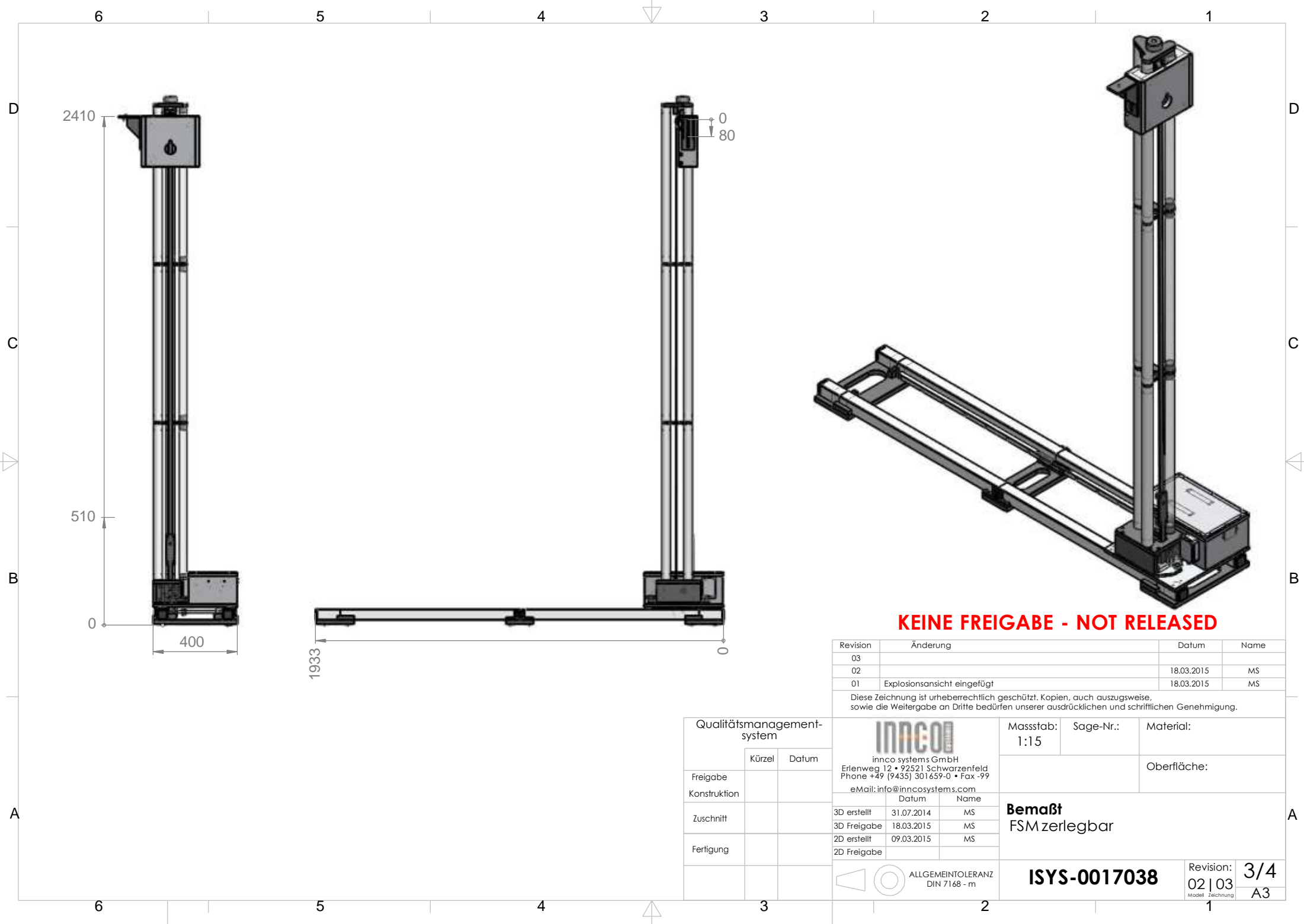

KEINE FREIGABE - NOT RELEASED

Revision	Änderung	Datum	Name
03			
02		18.03.2015	MS
01	Explosionsansicht eingefügt	18.03.2015	MS

Diese Zeichnung ist urheberrechtlich geschützt. Kopien, auch auszugsweise, sowie die Weitergabe an Dritte bedürfen unserer ausdrücklichen und schriftlichen Genehmigung.

Qualitätsmanagement-system	
Kürzel	Datum
Freigabe	
Konstruktion	
Zuschnitt	
Fertigung	

 innco systems GmbH Erlenweg 12 • 92521 Schwarzenfeld Phone +49 (9435) 301659-0 • Fax -99 eMail: info@innco systems.com			Masstab: 1:15	Sage-Nr.:	Material:										
<table border="1"> <thead> <tr> <th>Datum</th> <th>Name</th> </tr> </thead> <tbody> <tr> <td>3D erstellt</td> <td>31.07.2014 MS</td> </tr> <tr> <td>3D Freigabe</td> <td>18.03.2015 MS</td> </tr> <tr> <td>2D erstellt</td> <td>09.03.2015 MS</td> </tr> <tr> <td>2D Freigabe</td> <td></td> </tr> </tbody> </table>			Datum	Name	3D erstellt	31.07.2014 MS	3D Freigabe	18.03.2015 MS	2D erstellt	09.03.2015 MS	2D Freigabe		Oberfläche:		
Datum	Name														
3D erstellt	31.07.2014 MS														
3D Freigabe	18.03.2015 MS														
2D erstellt	09.03.2015 MS														
2D Freigabe															

Bemaßt FSM zerlegbar		ISYS-0017038	Revision:	3/4
			02 03 <small>Modell Zeichnung</small>	A3

 ALLGEMEINTOLERANZ
 DIN 7168 - m