

FOR EMC ANECHOIC CHAMBERS

ITF MATERIAL

It is a composite type radio wave absorber that combines Styrofoam as a support material, a radio wave absorber ITF material that utilizes the ohm loss of the resistance film, and a radio wave absorber material IB material that utilizes the magnetic loss of ferrite.

Resistive film is a material that contains conductive fibers in a mixed organic / inorganic base material and is flame-retardant.

The composite type absorber is designed so that the radio wave absorber IB material efficiently absorbs radio waves in the low frequency region of about 30 to 500 MHz and the ITF material efficiently absorbs radio waves in the high frequency region of 500 MHz or more, making the best use of the characteristics of each loss material. It has excellent radio wave absorption performance from low frequency 30MHz.

* Used in combination with ferrite radio wave absorber IB material.



ITF-090, ITF-130

It is a newly developed TDK compound radio wave absorber. It is a unit configuration type radio wave absorber that has excellent radio wave absorption characteristics over a wide band and has achieved compactness, weight reduction, and price reduction.

Widely used in 3m / 10m method anechoic chambers and large anechoic chambers for special purposes.

FEATURES

- Ultra-wideband electromagnetic absorber.
- Lightweight.
- Long service life.
- Fire retardant (UL94HBF)
- The exterior is white, creating a bright interior space.

STANDARD MATERIALS

Material name	Length (cm)	Standard weight* (kg)	Applicable anechoic chambers
ITF-045	45	1	Compact (3-meter test range), 3-meter test ranges
ITF-090	95	1.5	3-meter and 10-meter test ranges
ITF-130	130	2	10-meter test ranges
ITF-160	160	2.5	10-meter test ranges

* Not including the mass of ferrite

PRODUCT IDENTIFICATIONS

I TF - 090
(1) (2) (3)

- (1) TDK electromagnetic absorbers
- (2) Base material code (TF: Styrofoam with resistance film)
- (3) Length dimensional code (090: 95cm)

SHAPES AND DIMENSIONS

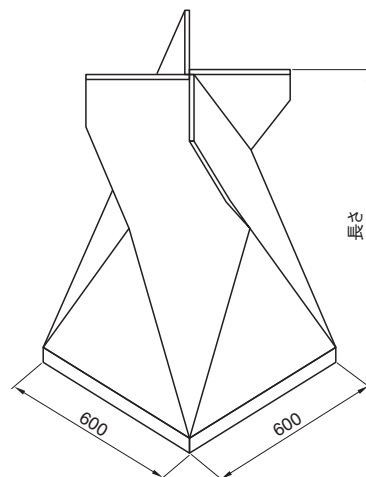

Dimensions in mm

TYPICAL ABSORPTION CHARACTERISTICS (VERTICAL INCIDENCE)

Unit: dB

Material name	30MHz	50MHz	100MHz	500MHz	1GHz	5GHz	18GHz	40GHz
ITF-045	18	25	18	18	18	18	18	18
ITF-090	24	22	20	20	20	20	20	20
ITF-130	28	22	28	22	23	20	20	20
ITF-160	28	23	25	23	25	20	20	20

⚠ Please be sure to request delivery specifications that provide further details on the features and specifications of the products for proper and safe use. Please note that the contents may change without any prior notice due to reasons such as upgrading.