

Dual EMI Filters for 4...20 mA Loops

Protect integrity of your data in a high-noise environment

OnFILTER' data filters protect your 4...20 mA data from EMI reducing errors and malfunction, and enabling uninterrupted operation of automated equipment.

Signals from analog sensors often influenced by unwanted high-frequency signals (EMI) from noisy cables that run in the same bundle with sensor wires. Especially affected are the sensors used in conjunction with VFD (variable frequency drives), servo and stepper motors, with the cables running along noisy power (AC or DC) wires, and overall with long run cables.

OnFILTER' data EMI filters block high-frequency interference while being completely transparent to the data signals within specified range. Filters work also with 4...20 mA-controlled actuators, preventing false operation.

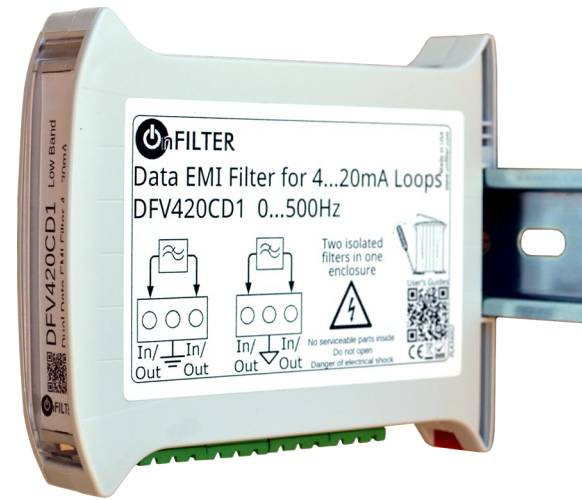

Applications

- Industrial control
- Utilities
- Oil and gas industry
- HVAC
- Water management
- Solar/PV
- Robotics
- Telemetry
- HART (highway addressable remote transducer) compatible
- Aerospace/Military
- Wherever EMI is a problem

Features

- Two independent filters in one package
- Passive—no power needed
- Reduction of EMI on analog data lines
- Differential and common mode
- Data bandwidth up to 20kHz
- Slim design—22.5mm wide—fits in tight spaces
- Easy installation

Two Separate Filters in One

DF420CDx filters contains two galvanically-separated EMI filters, providing you with compact solution in your already crowded panel.

No Power Needed

Data filters are completely passive—they don't need power to operate. This simplifies installation and lowers the cost

High and Low Band Options

We offer two option: for most sensors with slow-changing signals the bandwidth is 500Hz; for higher speed sensors such as in HART system, the bandwidth is 20kHz (see ordering information on the back)

Transparent to Data

Two models with different bandwidth provide complete transparency for your signals. Your sensors and actuators won't even know that the filter is there

Small and Inobtrusive

DF420CDx-N filters are DIN Rail mounted, very slim (22.5mm wide) and can fit in the most crowded places anywhere DIN rail is present.

Data EMI Filters
DFV420CD1
DFV420CD2
DIN-Rail Mounted

Notes on Data Bandwidth

Depending on the type of sensor and how fast the data need to be updated, the bandwidth of the signal may vary. Most of 4..20 mA sensors and actuators are fairly slow in comparison with digital data. A temperature sensor, for example, does need to send information thousand times per second. The lower the signal bandwidth, the better the filter can be configured so that it does not materially affect the useful signal but can effectively suppress EMI. However, HART (highway addressable remote transducer) protocol may require data rate of at least 2.2 kHz. This is why we have two models for different data speed. If you use slow data speed—within 500 Hz data rate — select DFV420CD1 as it will provide better EMI suppression. For faster data signals—up to 20 kHz data rate —use DFV420CD2 model.

Recommended Data Passbands for Data EMI Filters

Absolute Majority of Sensors
DFV420CD1 Normalized Output, dB

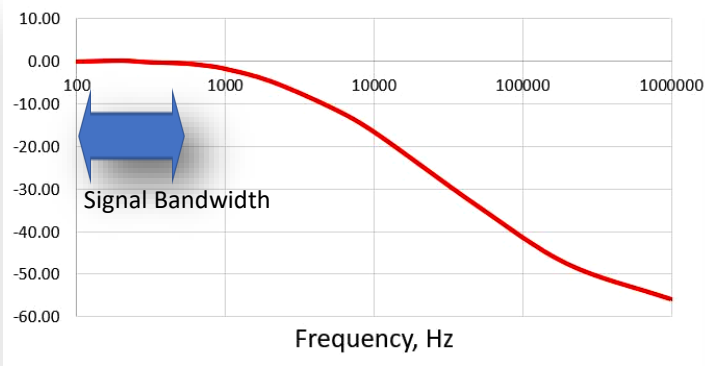

High-Speed and HART Sensors
DFV420CD2 Normalized Output, dB

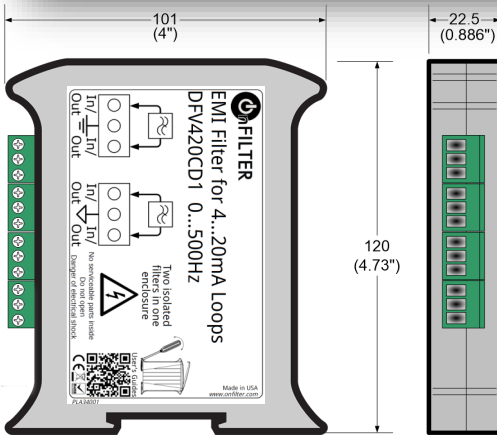
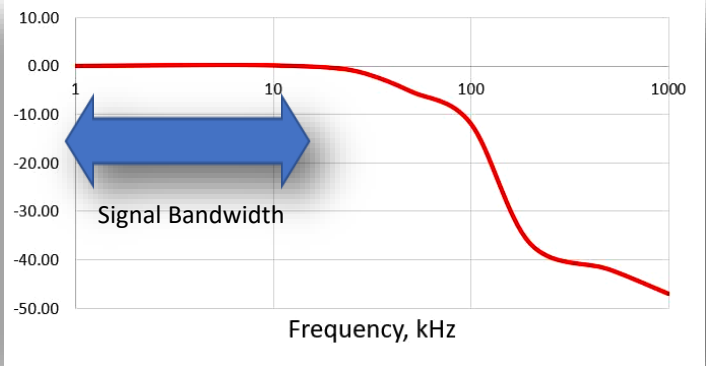

DFV420CDx Mounting Dimensions

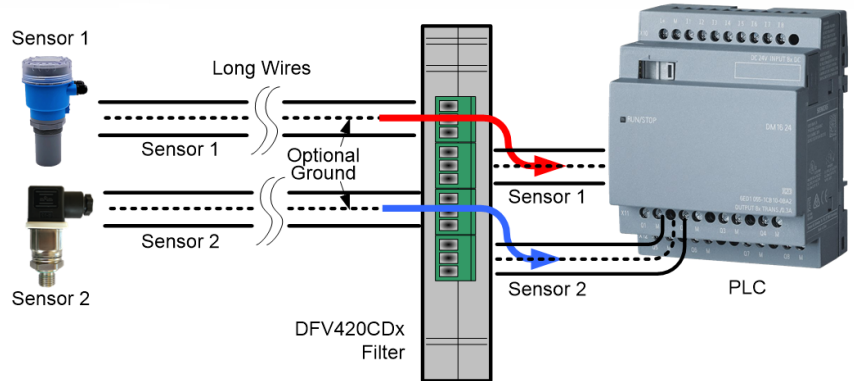

Typical Connections of DFV420CDx with sensors
The two filters inside are completely separate and are galvanically isolated from each other

Important: Analog Data Only

DF420CDxN data filters are designed for analog 4...20 mA data. Even though in some cases they may accidentally function with a particular digital interface, we do not recommend it as they absolutely not guaranteed to work with high-speed digital signals.

Need panel-mounted filters?
Please see DF420CDx filters at
www.onfilter.com



Ordering Information

Model	Included Cable Plug Type
DF420CD1-N	DC to 500 Hz data rate
DF420CD2-N	DC to 20 kHz data rate



OnFILTER, Inc.

730 Mission Dr. Ste. 102
Santa Cruz, CA 95060 U.S.A.
Tel. +1.831.824.4052
FAX +1.206.350.7458
www.onfilter.com
info@onfilter.com

