

CDN T2

for 2 unshielded, balanced lines

Coupling / decoupling networks (CDN) for immunity tests acc. to EN 61000-4-6 / IEC 1000-4-6

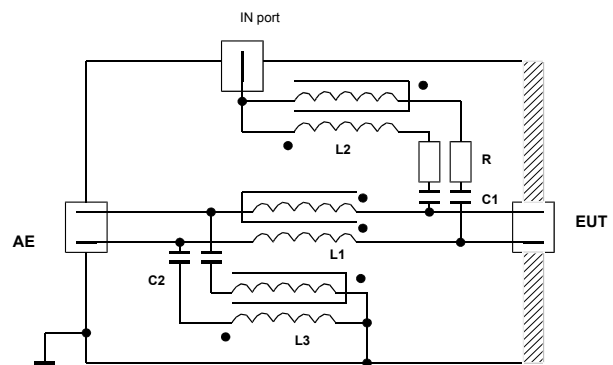

Circuit diagram CDN T2

- **Order Number: T2**
- **50Ω-termination included**

Technical data:		
EUT / AE Connection	AC voltage:	150V _{eff}
	DC voltage:	200V
	Rated current:	0.5A _{eff}
	Connectors:	Terminal strip
RF in	Frequency-range:	150kHz - 230MHz
	Connector:	BNC, 50Ω
	RF constant power:	6W
Common-mode impedance	150kHz - 26MHz:	130 - 170Ω
	26MHz - 230MHz:	105 - 210Ω
Insertion loss Generator / EUT (AE connector open/ short-circuit)	150kHz - 80MHz:	a = 10dB ±1dB
	80MHz - 230MHz:	a = 10dB + 2dB
Decoupling attenuation Generator / AE (EUT connector = 150Ω)	150kHz - 80MHz:	a > 35dB
	80MHz - 230MHz:	a > 30dB
Transmission loss EUT/AE (50Ω-System)	DC - 100kHz:	a < 1dB
	100kHz - 1MHz:	a < 10dB