

CDN S1

for 1 shielded line

Coupling / decoupling networks (CDN) for immunity tests acc. to EN 61000-4-6 / IEC 1000-4-6

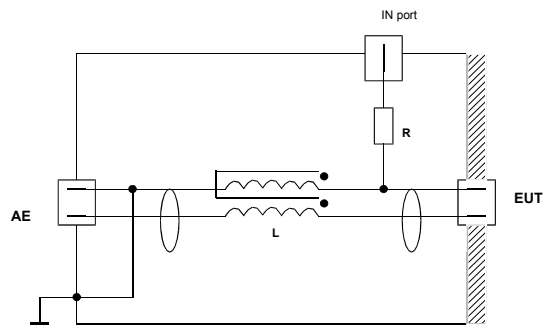

Typical circuit diagram CDN S1

- **Order Number: S1**
- **50Ω-termination included**
- **Available for 50Ω and 75Ω lines**

Technical data:		
EUT / AE Connection	AC voltage:	250V _{eff}
	DC voltage:	400V
	Rated current:	0.5A _{eff}
	Connector:	BNC
RF in	Frequency-range:	150kHz - 230MHz
	Connector:	BNC, 50Ω
	RF constant power:	6W
Common-mode impedance	150kHz - 26MHz:	130 - 170Ω
	26MHz - 230MHz:	105 - 210Ω
Insertion loss Generator / EUT	150kHz - 230MHz:	a = 10dB ±1dB
Decoupling attenuation Generator / AE (EUT-Connection: 150Ω)	150kHz - 80MHz:	a > 55dB
	80MHz - 230MHz:	a > 35dB
Transmission loss EUT/AE (50Ω-System)	DC - 10MHz:	a < 0.2dB
	10MHz - 100MHz:	a < 0.5dB
	100MHz - 500 MHz:	a < 3dB